



NEPAL NATIONAL BUILDING CODE

NBC 204: 2015



GUIDELINES FOR EARTHQUAKE RESISTANT BUILDING CONSTRUCTION: EARTHEN BUILDING

This publication represents a standard of good practice and therefore takes the form of recommendations. Compliance with it does not confer immunity from relevant legal requirements, including bylaws

मिति २०७२।१।६ को नेपाल सरकार, मन्त्रीस्तरीय निर्णयानुसार स्वीकृत र मिति २०७३।७।२९ मा नेपाल राजपत्रमा सुचना प्रकाशित

Government of Nepal
Ministry of Urban Development
Department of Urban Development and Building Construction
Babar Mahal, Kathmandu, Nepal

Preface

The first revision of National Building Code , NBC 204:1994 Guidelines for Earthquake Resistant Building Construction: Earthen Building (EB) was completed in 2015AD. This code was revised on the basis of new experiences in construction practices and increased knowledge and improved understanding in engineering design , construction technology and research sector. Department of Urban Development and Building Construction (DUDBC) under Ministry of Urban Development (MoUD) has carried out study for update of Nepal National Building Codes which revealed the areas of corrections and improvements in the prevailing existing codes. It was decided to carry out revision of some codes. DUDBC then hired consultant for the preparing revision of codes. After submission of the update from the consultant, the same was reviewed from expert committee through series of meetings. After incorporating suggestions from the expert committee, the proposed revision was further reviewed by DUDBC and then forwarded to MoUD for approval.

The revised code, NBC 204:2015 Guidelines for Earthquake Resistant Building Construction: Earthen Building (EB) was approved from MoUD by Government of Nepal dated 21st December,2015 and the notice was published in Nepal Gazette in 14thNovember,2016.

The revision of this code was undertaken under the aegis of Building Construction Management Upgrading (Consolidation) Committee, Expert Committee and In-house Review Committee which then comprised of the following :

1. Building Construction Management Upgrading (Consolidation) Committee

Chairman

Mr. Arjun Kumar Karki Secretary, MoUD

Members

Mr. Gopi Mainalee	Joint Secretary., NPC
Mr. Uday Raj Sapkota	Representative, MoLJPA
Mr. Ganesh Prasad Pathak	Representative, NCS
Dr. Tri RatnaBajracharya	Dean, Institute of Engineering (IOE)
Mr. Gopi Khanal	Joint Secretary, MoFALD (Municipality Section)
Mr.Rajiv Thakur	Representative, RECAST
Mr. Gaurinath Rimal	Expert
Mr. Manohar Rajbhandari	Expert
Mr.Bharat Sharma	Expert

Member –Secretary

Mr. Shambhu K.C. Director General, DUDBC

2. Expert Committee for Review & Update

Dr. Prem Nath Maskey	Professor, IOE, TU
Dr. Jishnu K. Subedi	IOE, TU
Dr. Haridarshan Shrestha	Associate Professor, IOE, TU
Dr. Purushottam Dangol	Structural Engineer
Dr. Santosh Shrestha	Structural Engineer
Mr. Ganesh Prasad Pathak	Director, NBSM
Mr. Dwarika Shrestha	SDE, DUDBC
Mr. Prakirna Tuladhar	SDE, DUDBC
Mr. Nabin Malakar	Engineer, DUDBC

3. DUDBC In-house Review & Update Committee

Mr. Shambhu K.C.	DG, DUDBC
Mr. Ramesh Prasad Singh	DDG, DUDBC
Mr. Shiva Hari Sharma	DDG,DUDBC
Mr. Maniram Gelal	DDG, DUDBC
Mrs. Mina Shrestha	SDE, DUDBC
Mr. Suman Salike	SDE, MOUD
Mr. Sagar Krishna Joshi	SDE,DUDBC
Mr. Binay Charan Shrestha	SDE,DUDBC
Mr. Machakaji Maharjan	SDE, DUDBC
Mr. Parikshit Kalaria	SDE, DUDBC
Mr. Pramod Karmacharya	Engineer ,DUDBC
Mr. Himal KC	Engineer DUDBC
Mr. Manoj Nakarmi	Engineer, DUDBC
Mr. Pravin Shah	Engineer, DUDBC
Mr. Ganesh Karmacharya	Engineer, DUDBC
Mr. Lila Khatiwada	Engineer, DUDBC
Mr. Chandra KajiGurung	Engineer, DUDBC
Mr. Surendra Vaidya	Engineer, DUDBC
Mr. Ram Chandra Thapa	Engineer, DUDBC
Mr. Bivek Sigdel	Engineer, DUDBC
Mr. Debendra Dev Khanal	Engineer, DUDBC
Ms. Monika Maharjan	Engineer, MoUD

We would like to express our sincere thanks to all those who contributed directly and indirectly for the revision of this code. We hope the revised code will be able to address the issues on the construction of earthquake resistant earthen buildings as it incorporates the recent knowledge and technology in the sector.

TABLE OF CONTENTS

Preface	Error! Bookmark not defined.
0. Foreword.....	1
0.1 Introduction.....	1
0.2 Objective.....	1
0.3 Background.....	1
0.4 Applicability.....	1
0.5 Interpretation.....	1
0.6 Terminology.....	2
1 Scope.....	3
1.1 Type of Buildings Covered.....	3
1.2 Limitation.....	3
2 General Requirements for Earthquake-Resistance Construction	4
2.1 Proper Site Selection	4
2.2 Appropriate Planning.....	4
2.3 Good Foundations Resting on a Firm Base.....	4
2.4 Creating a Box Effect	4
2.5 Better Bonding Between Masonry Units	4
2.6 Controlled Size and Location of Openings	4
3 Materials	5
3.1 Mud.....	5
3.2 Adobe (Sun-Dried Clay Bricks/Blocks).....	5
3.3 Mud Mortar.....	6
3.4 Bamboo.....	6
3.5 Timber.....	6
4 Site Considerations.....	7
4.1 General.....	7
4.2 Site Selection.....	7
4.2.1 Geological Faults or Ruptured Areas.....	7
4.2.2 Areas Susceptible to Landslide.....	7
4.2.3 Boulder Hazard	8
4.2.4 River Banks.....	8
4.2.5 Swamp/Marshy Area.....	8
4.2.6 Steep Slopes	8
4.2.7 Water-Logged Areas	8
4.2.8 Filled Areas	8

5	Planning	9
	5.1 Shape.....	9
	5.2 Proportions.....	10
	5.3 Storey Height	10
	5.4 Number of Storeys.....	10
6	Foundation	11
	6.1 General.....	11
	6.2 Strip Foundation.....	11
	6.3 Foundations on Sloping Sites.....	11
7	Walls.....	13
	7.1 General.....	13
	7.1.1 Mud Wall Construction	13
	7.1.2 Rammed Earth Wall Construction	14
	7.1.3 Adobe (Sun-Dried Bricks/Blocks) Wall Construction	15
	7.2 Wall Thickness.....	16
	7.3 Unsupported Wall Length.....	16
	7.4 Height of Walls	17
	7.5 Protection of Mud Walls.....	17
	7.5.1 Foundation	17
	7.5.2 Damp Proof Course (DPC).....	18
	7.5.3 Roof Projections	18
	7.5.4 Non-Erodible Mud Plaster (NEM).....	18
	7.6 Corners and Junctions.....	18
8	Openings in Walls	19
9	Floors and Roofs	20
	9.1 Structure.....	20
	9.1.1 Posts and Capitals.....	20
	9.1.2 Beams and Bearings	24
	9.1.3 Wall Plates	25
	9.1.4 Joists and Rafters.....	26
	9.2 Floor Finishings and Roof Coverings	27
	9.2.1 Bridging Materials.....	27
	9.2.2 Floor Finishing	29
	9.2.3 Roof Covering.....	29
	9.2.3.1 Mud.....	29
	9.2.3.2 Thatch.....	30
	9.2.3.3 Slates.....	31
	9.2.3.4 Clay Tiles.....	31
	9.2.3.5 MCR Tiles	32
	9.2.3.6 CGI Sheets.....	32
	9.3 Bamboo for Flooring and Roofing.....	33
	9.3.1 Bamboo Flooring.....	33
	9.3.2 Bamboo Roofing.....	34

10	Seismic-Resistant Components.....	36
10.1	Vertical Reinforcement.....	36
	10.1.1 Bamboo	36
	10.1.2 Timber	38
10.2	Horizontal Bands.....	38
	10.2.1 Bamboo Bands.....	39
	10.2.2 Timber Bands	40
10.3	Gable Bands	41
10.4	Diagonal Bracing.....	42
10.5	Lateral Restrainers.....	43
11	Miscellaneous.....	44
11.1	Damp-Proof Courses.....	44
11.2	Drainage.....	45
11.3	Specification and Diameter of Nails.....	45
	11.3.1 Nails.....	45
	11.3.2 Nails Diameter.....	45
	11.3.3 Nails Length.....	46
APPENDIX - 1HARVESTING AND PRESERVING BAMBOO FOR CONSTRUCTION		47
1	Harvesting and Preservative Treatment	47
1.1	Harvesting	47
	1.1.1 Harvesting Guidelines	47
	1.1.2 Clump Cure	47
1.2	Preservative Treatment.....	47
	1.2.1 Water Leaching.....	48
	1.2.2 White Wash and Other Coatings.....	48
	1.2.3 Brushing, Swabbing, Spraying and Dipping	48
1.3	Fire-Retarding Treatment	49
1.4	Storage	49
APPENDIX - 2FIRE-RETARDANT TREATMENT FOR THATCH.....		50
1	General.....	50
1.1	Materials Required	50
1.2	Method of Preparation.....	50
	1.2.1 Preparation of Stabilised Mud Mortar.....	50
	1.2.2 Preparation of Cut-Back ₁ Bitumen (for NEM).....	50
	1.2.3 Preparation of NEM Mortar.....	51
	1.2.4 Preparation of Cut-Back ₂ Bitumen for Stabilised Mud Slurry	51
	1.2.5 Preparation of Stabilised Mud Slurry ₁ for NEM	51
	1.2.6 Preparation of Stabilised Mud Slurry ₂ for Fire-Retardant Plaster	51
1.3	Method of Application.....	52
	1.3.1 Dressing of Roof Surface.....	52
	1.3.2 Application of Stabilised Mud Plaster.....	52
	1.3.3 Application of Stabilised Mud Slurry ₁	52

1.3.4	Application of NEM plaster.....	52
1.3.5	Application of Stabilised Mud Slurry ₂	53
APPENDIX - 3 PROTECTION OF MUD WALLS.....		54
1	Non-Erodible Mud Plaster (NEM).....	54
1.1	Materials Required.....	54
1.2	Method of Preparation.....	54
1.2.1	Preparation of Stabilised Mud Mortar.....	54
1.2.2	Preparation of Bitumen Cut-Back.....	54
1.2.3	Preparation of NEM mortar.....	55
1.2.4	Preparation of Stabilised Mud Slurry.....	55
1.3	Method of Application.....	55
1.3.1	Dressing of Wall Surface.....	55
1.3.2	Application of NEM plaster.....	55
1.3.3	Application of Stabilised Mud Slurries.....	56
2	Composite Walls.....	56
APPENDIX - 4TERMITE CONTROL IN BUILDINGS.....		57
1	General.....	57
1.1	Site Clearance.....	57
1.2	Chemical Barriers.....	57
1.3	Precautions.....	58
APPENDIX - 5SEASONING OF TIMBER.....		59
APPENDIX - 6REFERENCE MATERIALS.....		67
APPENDIX - 7GLOSSARY.....		68

LIST OF FIGURES

Figure 3.1 : Field testing of Strength of Soil.....	5
Figure 3.2 : Lab Testing of Strength of Soil and Adobe.....	6
Figure 5.1 : Recommended Forms of Buildings.....	9
Figure 6.1 : Details of Strip Footing Foundation for an EB.....	11
Figure 6.2 : Foundation on Sloping Land.....	12
Figure 7.1 : Bamboo Reinforcement Detail in Mud Wall Construction.....	13
Figure 7.2 : Rammed Earth Wall Construction	14
Figure 7.3 : Adobe Brick/Block Wall Construction	15
Figure 7.4 : Buttresses on Walls	16
Figure 7.5 : Protection of Mud Wall Foundations	17
Figure 7.6 : Reinforcing of Corners and Junctions of Mud Walls	18
Figure 8.1 : Openings for Earthen Buildings.....	19
Figure 9.1 : Details of Fixing Posts on Base Pads	21
Figure 9.2 : Details of Fixing of a Series of Posts on a Base Strip.....	22
Figure 9.3 : Details of Fixing Capitals on the Posts.....	23
Figure 9.4 : Alternative Details for Fixing Struts on Posts and Beams	23
Figure 9.5 : Details of Fixing Keys on Beams.....	24
Figure 9.6 : Details for Fixing Wall Plates	25
Figure 9.7 : Details for Fixing Joists and Rafters	26
Figure 9.8 : Details for Fixing Bridging Materials to Joists and Rafters	28
Figure 9.9 : Details of Improved Mud Roofing.....	29
Figure 9.10 : Details of Improved Thatched Roofing.....	30
Figure 9.11 : Details of Laying Slate.....	31
Figure 9.12 : Details of Fixing Clay Tiles	31
Figure 9.13 : Details for Fixing MCR Tiles	32
Figure 9.14 : Details for Fixing CGI Sheets.....	32
Figure 9.15 : Details of Bamboo Flooring.....	33
Figure 9.16 : Details of Simple Bamboo Roofing	34
Figure 9.17 : Details of Trussed Bamboo Roofing.....	35
Figure 10.1 : Bamboo as Vertical Reinforcement	37
Figure 10.2 : Timber as Vertical Reinforcement	38
Figure 10.3 : Bamboo for Horizontal Bands	39
Figure 10.4 : Timber for Horizontal Bands	40
Figure 10.5 : Details for Gable Bands.....	41
Figure 10.6 : Details for Diagonal Bracing	42
Figure 10.7 : Lateral Restrainers.....	43
Figure 11.1 : Damp-Proof Courses	44
Figure 11.2 : Surface Water Drainage around a Building.....	45
Figure A3.1 : Composite Wall.....	56

LIST OF TABLES

Table 3.1 : List of Hardwood and Softwood.....	7
Table 7.1 : Minimum Wall Thicknesses (mm) for Different Wall Types	16
Table 9.1 : Size of Columns (mm).....	20
Table 9.2 : Size of Beams (mm) for Various Spans	25
Table 9.3 : Minimum Size (mm) of Joists and Rafters	27

0. Foreword

0.1 Introduction

A number of documents for better seismic-resistant construction have been prepared under the National Building Code Development Project (NEP/88/054/21.03) in 1993. **Guidelines for Earthquake Resistant Building Construction: Earthen Buildings (EB)** is one of them. Originally prepared document has been revised by DUDBC in March 2014. This document provides basic guidelines for the earthquake resistance of earthen buildings in particular.

0.2 Objective

This guideline is prepared in order to raise the seismic safety of earthen buildings. This is intended to be implemented by the owner/builder with some assistance from technicians. This could also act as a basic guideline for architectural design and construction detailing of Earthen Buildings (EB).

0.3 Background

The devastating earthquakes in the past have proved the vulnerability of most of the vernacular buildings of Nepal. Enormous life and property were lost due to the collapse of buildings which employed mud walls as their main load-bearing elements. Earthquakes can neither be prevented nor predicted precisely. But the large-scale destruction can be minimized by employing seismic-resistant measures in buildings. This can be achieved by the use of existing building materials in appropriate ways. This **Guideline for Earthquake-Resistant Building Construction: Earthen Buildings** provides the improved techniques that can raise the level of seismic safety of earthen buildings.

0.4 Applicability

The recommendations set forth in this standard shall be mandatory for all types of LSM residential buildings to be built throughout Nepal.

Other occupancy types of LSM buildings shall be designed by competent professional engineers.

0.5 Interpretation

0.5.1 In this standard the word “shall” indicates a requirement that must be adopted in order to comply with the Guidelines, while the word “should” indicates recommended practice.

0.5.2 Words used in either the singular or plural shall be treated as plural or singular as deemed necessary, and vice-versa wherever the context so requires it.

0.6 Terminology

In this guidelines, unless inconsistent with the context:

EB means **Earthen Buildings** that employ mud walls or masonry units that are made with unstabilized mud-like adobe blocks, sun-dried clay bricks, etc, laid in a mud mortar.

1 Scope

1.1 Type of Buildings Covered

The guidelines deals with the design and construction aspects for improving earthquake resistance of earthen houses, without the use of stabilizers, such as cement, lime, asphalt, admixtures, etc.

1.2 Limitation

EB buildings required to conform to this Guidelines shall not exceed one storey in height plus an additional attic floor.

2 General Requirements for Earthquake-Resistance Construction

The principal seismic-resistant factors have to be properly incorporated during the construction of a building. Some basic factors leading to enhanced seismic safety are:

2.1 Proper Site Selection

The construction site has to be stable and safe enough to withstand the total building load, including that of its occupants and their belongings. A proper site for the building shall be selected in accordance with section 4 of this guideline.

2.2 Appropriate Planning

The shape, size and proportions of a building are important for its seismic safety. Buildings with asymmetric plans and elevations are more vulnerable to earthquakes than those having symmetrical ones. The recommended form and proportion of buildings shall be as stated in section 5.

2.3 Good Foundations Resting on a Firm Base

The quality of foundations and the base on which the foundations rest are equally important for the safety of a building. General site investigation shall be carried out as outlined in section 4. The dimensions and quality of masonry for the foundation shall be as stated in section 6.

2.4 Creating a Box Effect

A building has to act as a single unit for it to have good earthquake resistance. This can be achieved by incorporating certain elements in its construction. The following elements shall be introduced as recommended in section 10.

- Vertical reinforcement
- Horizontal bands well-connected to the vertical reinforcement and embedded in masonry
- Diagonal bracing (horizontal and vertical)
- Lateral restraints

2.5 Better Bonding between Masonry Units

The type and quality of the bond within the walling units is the main contributor to the integrity and strength of the walls. All the masonry units have to be properly laid to provide the integrity.

2.6 Controlled Size and Location of Openings

Large un-stiffened openings create a soft-storey effect which leads to a greater deformation of a building during an earthquake. To prevent such effects, the opening size and location have to be controlled. The recommended proportions and locations of openings are given in section 8.

3 Materials

3.1 Mud

The mud used for walls shall be free from organic materials. It should be neither too sandy nor too clayey. The sand content shall not be more than 40 % by volume.

3.2 Adobe (Sun-Dried Clay Bricks/Blocks)

The mud used for making sun-dried bricks/blocks shall be free from organic materials. These bricks shall preferably be dried in a shed to prevent large shrinkage cracks. They shall be free from major defects and obvious cracks.

3.2.1 Suitability of soil

The quality of materials, particularly clay content of the soil may vary somewhat for the type of construction. But in general the following qualitative tests are sufficient for determining the suitability of a soil for earthen construction:

3.2.1.1 Field Test

a. Dry strength test

Five or Six small balls of soil of approximately 2 cm in diameter are made. Once they are dry (after 48 hours), each ball is crushed between the forefinger and the thumb. If they are strong enough that none of them breaks, the soil has enough clay to be used in the adobe construction, provided that some control over the mortar micro-fissures caused by the drying process is exercised, Fig 3.1

If some of the balls break, the soil is not considered to be adequate, because it does not have enough clay and should be discarded.

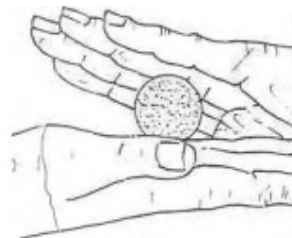

i) Making the ball



ii) Crushing the dried ball

Fig 3.1 Field Testing of Strength of Soil

b. Fissuring control test

At least eight sandwich units are manufactured with mortars made with mixtures in different proportions of soil and coarse sand. It is recommended that the proportion of soil to coarse sand vary between 1:0 and 1:3 in volume. The sandwich having the least content of coarse sand which, when opened after 48 hours, does not show visible fissures in the mortar, will indicate the most adequate proportion of soil/sand for adobe constructions, giving the highest strength.

3.2.1.2 Lab Test

Strength test of adobe

The strength of adobe can be qualitatively ascertained as follows: After 4 weeks of sun drying the adobe should be strong enough to support in bending the weight of a man, Fig 3.2. If it breaks, more clay and fibrous material is to be added. Quantitatively, the compressive strength may be determined by testing 10 cm cubes of clay after completely drying them. A minimum value of 1.2 N/mm² will be desirable.

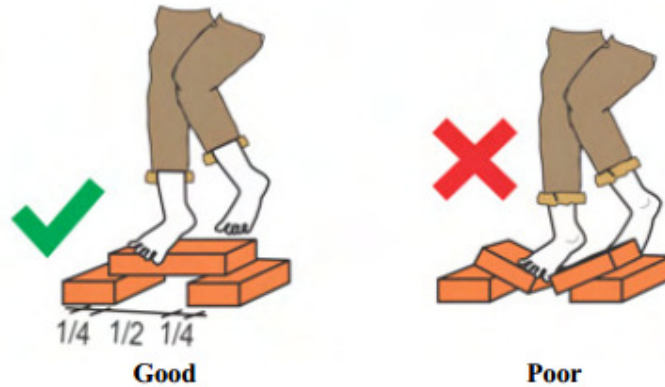

Fig 3.2 Qualitative testing of strength of soil and adobe

3.3 Mud Mortar

Mud for mortar shall be free from organic materials. It shall also be free from pebbles and other hard materials which would upset the mortar thickness. The sand content in the mud shall not be more than 30 % in order that a satisfactory cohesiveness is attained. Dry mud shall be thoroughly kneaded with water to achieve a dense paste.

3.4 Bamboo

Only matured bamboo that is a minimum of three years old and free from damage shall be used. It is preferable that treated bamboo be used. The treatment may be carried out in a traditional manner. One of the simplest ways is to soak the bamboo in running water two- three weeks continuously. (Details are presented in Appendix 1.)

3.5 Timber

Well seasoned locally available timber can be used. Seasoning should be done in a traditional manner. Preferably Sal wood, or any other locally available hardwood timber, shall be used instead of softwood timber for the main structural elements such as beams, columns, bands, etc. (According to indigenous experience, deciduous trees are much less susceptible to bacterial and insect rot if felled during August to December.) List of the hardwood and softwood timber available are as follows:

Table 3.1: List of Hardwood and Softwood

HARD WOOD	SOFT WOOD
Babul	Chir
Black Siris	Deodar
Dhaman	Jack
Indian Rose Wood(Shisam)	Mango
Jaman	Salla
Mesua	Simal
Oak	Uttis (Red)
Sain	Uttis (White)
Sal	
Sandan	
Sisso	
Teak	
Khair	

4 Site Considerations

4.1 General

The building site shall be the safest available with respect to natural hazards. Any existing buildings shall be studied for any evidence of inherent natural hazards in the locality. These hazards include susceptibility to landslides, erosion and land subsidence. The local practice used to manage such hazards, if any, shall be judged against the required level of acceptable risk. Areas with a high potential of liquefaction during earthquakes should also be avoided.

4.2 Site Selection

Site selection shall be done so as to minimize the risk against natural hazards. No buildings shall be constructed in hazardous areas, including the areas stated here under:

4.2.1 Geological Faults or Ruptured Areas

Geological fault lines or rupture lines that are usually visible to the naked eye and are permanent, deep and active should be avoided. Buildings should be constructed at least 500 m away from these lines.

4.2.2 Areas Susceptible to Landslide

Areas likely experience frequent landslides shall be avoided for construction of buildings. The simplest indication of sustained stability of a slope is the upright standing of trees on it. They would be inclined downwards in the case of unstable slopes.

4.2.3 Boulder Hazard

Nepal, being a mountainous country, has many places where boulders roll down bare hill slopes. These boulders can hit and damage a building. Therefore, buildings shall be constructed in such areas only after the provision of proper prevention by retaining walls and green barriers of bamboo groves is assured.

4.2.4 River Banks

It is preferable that river banks and areas susceptible to frequent flooding should be avoided. Construction on such areas can be undertaken only after carrying out protection works as suggested by specialists.

4.2.5 Swamp/Marshy Area

Construction on swamps or marshy areas shall only be undertaken on specialist advice.

4.2.6 Steep Slopes

Generally, soil slopes up to 20° are stable and good for construction. However, construction on steeper slopes is not restricted if there are proper retaining walls for the development.

4.2.7 Water-Logged Areas

Sites with permanent water-logged areas should be avoided. However, construction is allowable if the site is appropriately treated.

4.2.8 Filled Areas

No building foundation shall rest on filled ground. If a building is to be constructed on a filled-ground site, the foundation shall be deep enough so as to rest on the firm ground surface beneath the fill. Such depth should be minimum 600mm below from the firm ground.

5 Planning

5.1 Shape

Buildings which are symmetrical in plan and regular in elevation are safer than asymmetrical ones. Thus, it is preferable that buildings be symmetrical and regular. The different forms of recommended geometrical configurations are illustrated in Figure 5.1.



NO		YES	
PLAN	ELEVATION	PLAN	ELEVATION
 <p>$a \geq 3b$</p>		 <p>$a \leq 3b$</p>	
 <p>$a = b$ $a' = b'$</p>		 <p>$b'/b \leq 0.20a$</p>  <p>$a \leq 3b$ $a' \leq 3b'$</p>	 
		 <p>min 450</p>	 <p>Maximum Storeys 1 + Attic</p>

Figure 5.1: Recommended Forms of Buildings

5.2 Proportions

The length to breadth ratio of a building shall not exceed 3:1. The length to breadth ratio for any room or area enclosed by load-bearing walls inside the building shall also not exceed 3:1.

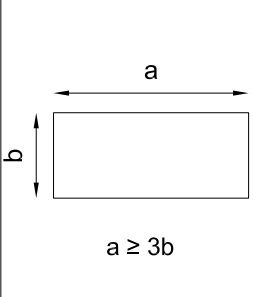
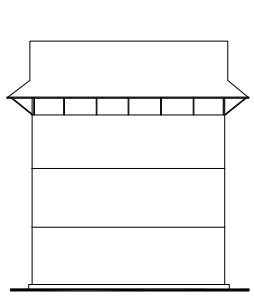
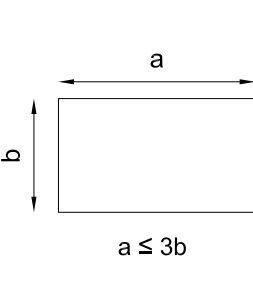
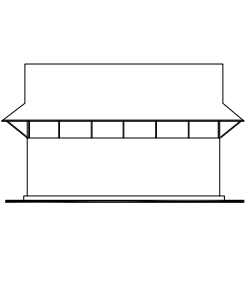
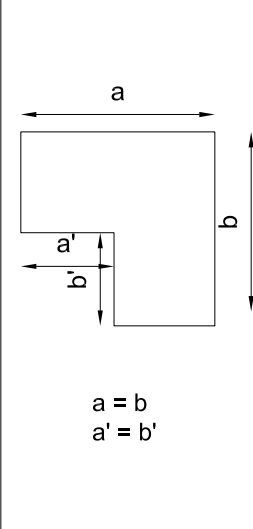
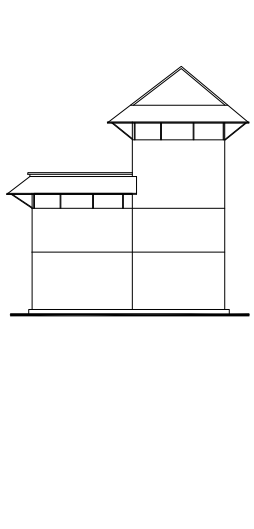
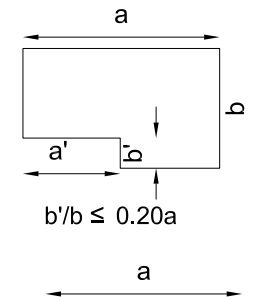
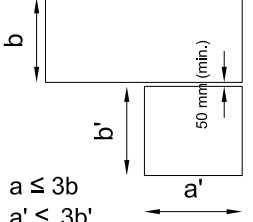
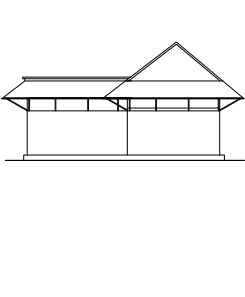
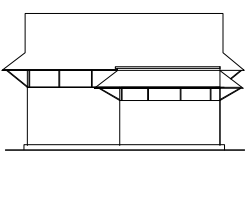
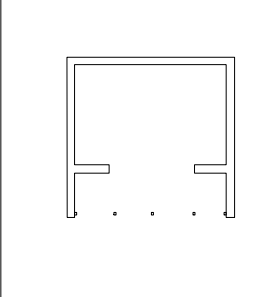
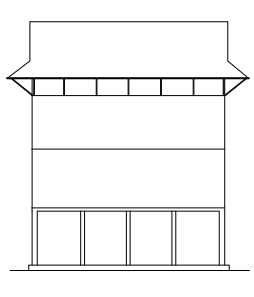
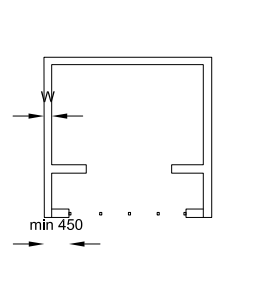
5.3 Storey Height

The floor to floor height of an Earthen Building (EB) shall not be less than 1.8 m and not greater than 2.5 m.

5.4 Number of Storeys

Earthen buildings shall be single-storied, but may have an additional attic floor. The maximum height (floor to floor) of a building shall not exceed 8 times the wall thickness of the superstructure.

6 Foundation

6.1 General

The foundation trench shall have a uniform width. The foundation bed shall be at the same level throughout the foundation unless strip footing is provided as explained in foundation for sloping sites (clause 6.3).

6.2 Strip Foundation

The construction details and dimensions of the strip foundation shall not be less than those illustrated in Figure 6.1.

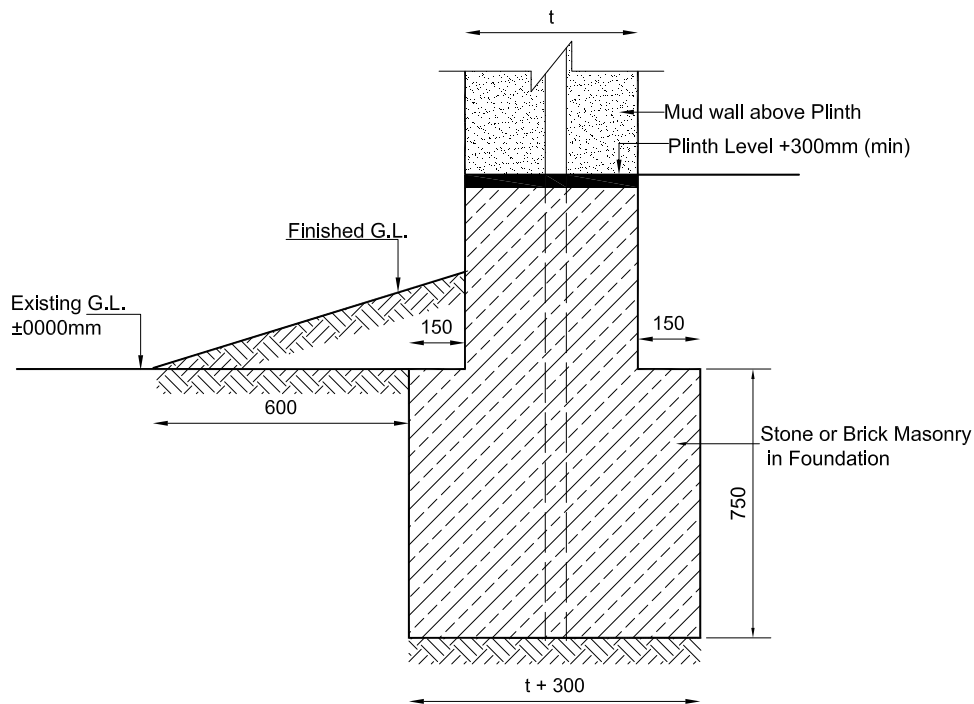

Figure 6.1: Details of Strip Foundation for an EB

6.3 Foundations on Sloping Sites

No Earthen building shall be built on land steeper than 20° (1:3, Vertical: Horizontal). Stepped strip footings shall be made for foundations on sloping land. The minimum depth of a foundation shall be measured from the existing ground level on the filled part and from the finished ground level on the cut part, and this shall not be less than 750 mm. Each step shall not be narrower than two times the wall thickness at the base of the superstructure, as shown in Figure 6.2.

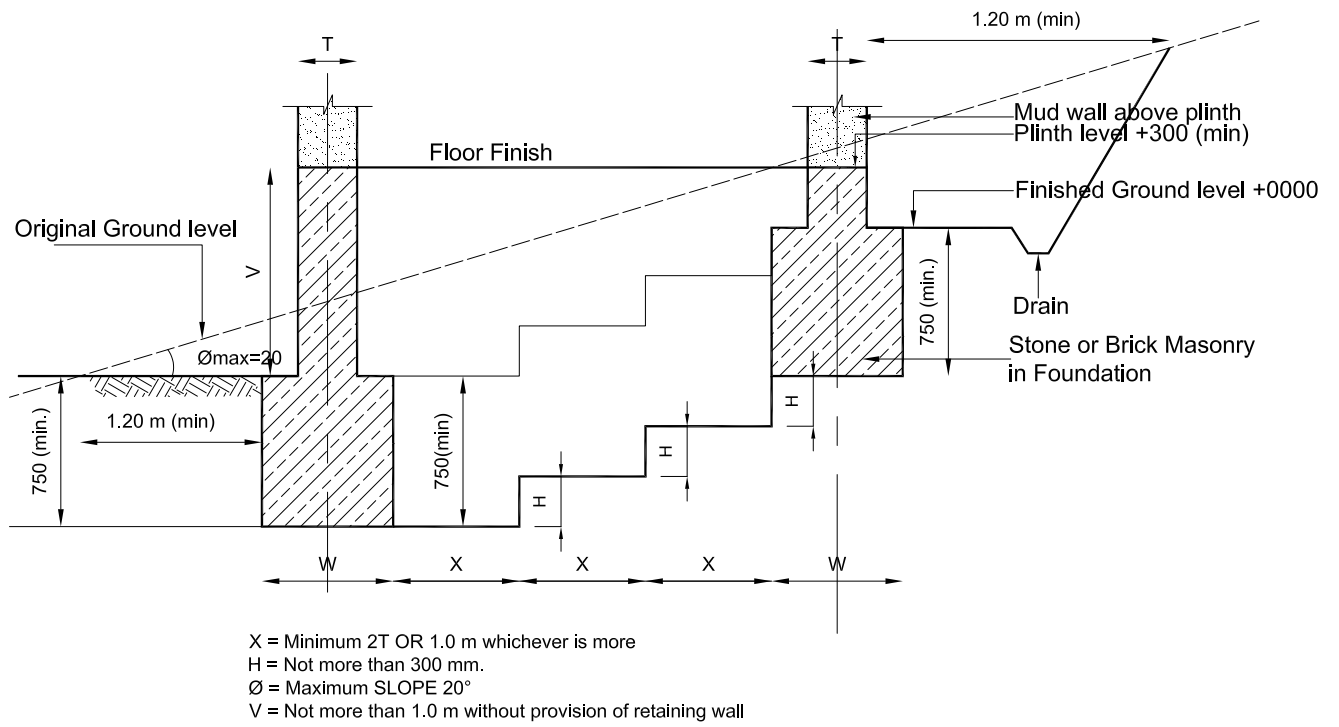

Figure6.2: Foundation on Sloping Land

7 Walls

7.1 General

Mud walls can be built successfully in a number of different ways. Among the prevailing types, the following are recommended. These walls shall be constructed as detailed in respective sections. The minimum wall thickness for these wall types shall be as tabulated in Table 7.1.

7.1.1 Mud Wall Construction

Mud walls shall be made in continuous layers of uniform thickness which shall not exceed 300 mm in height. The wall shall be true to a plumb line. The mud used for such walls shall be free from organic materials. The mud shall neither be completely dry nor contain excess water. Moist mud from the borrow pit may be stacked in layers to form a wall. Mud blocks, if directly used from the borrow pit, shall be laid with staggered vertical joints which are well packed with mud lumps. The mud can be kneaded with water for better workability. The quantity of water required depends on the quality and moisture content of the original mud. Excessive water content results in shrinkage cracks and other strength-related problems. As far as possible, such walls shall not be allowed to dry in direct sunlight, it being always better to leave the walls covered in order to reduce shrinkage cracks. After the completion of a layer not exceeding 300 mm, it shall be left for two to four days for drying before another layer is added on top of it.

The top surface shall be moistened for a few minutes prior to adding successive layers – for better bonding. Mud walls can be reinforced by bamboo strips laid horizontally and tied by cross-ties at each layer, as shown in Figure 7.1. The corners and junctions shall be constructed in accordance with the details described in section 7.6.

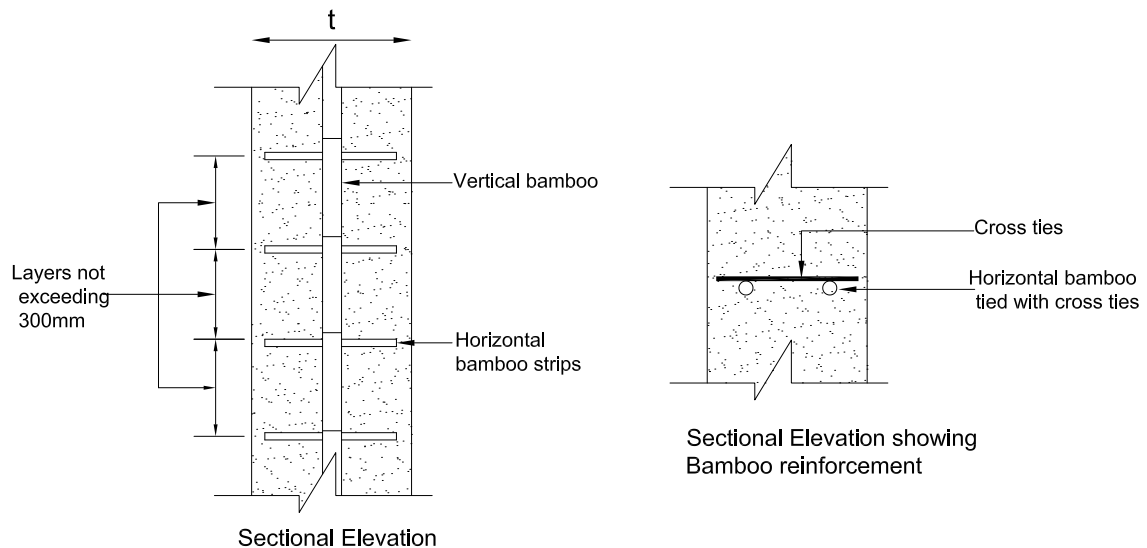

Figure 7.1: Bamboo Reinforcement Detail in Mud Wall Construction

7.1.2 Rammed Earth Wall Construction

Shuttering shall be completed prior to any ramming of earth to form a wall. The height of the shuttering shall match the maximum layer height of 450 mm. The mud shall be dumped between two side-shutters and rammed with mallets (timber hammers). Moist clay from the borrow pit shall be preferred to kneaded mud. The walls shall be made from continuous layers throughout the building, with each layer uniform in thickness and not exceeding 450 mm in height. The construction of successive layers shall be continued only after the existing top surface has been cured for a few minutes. The next layer may be constructed on the next day, but it is preferable to leave two days between layers for drying. For better performance, bamboo reinforcement, as stated in Clause 7.1.1, shall be provided. Other details shall be as illustrated in Figure 7.2.

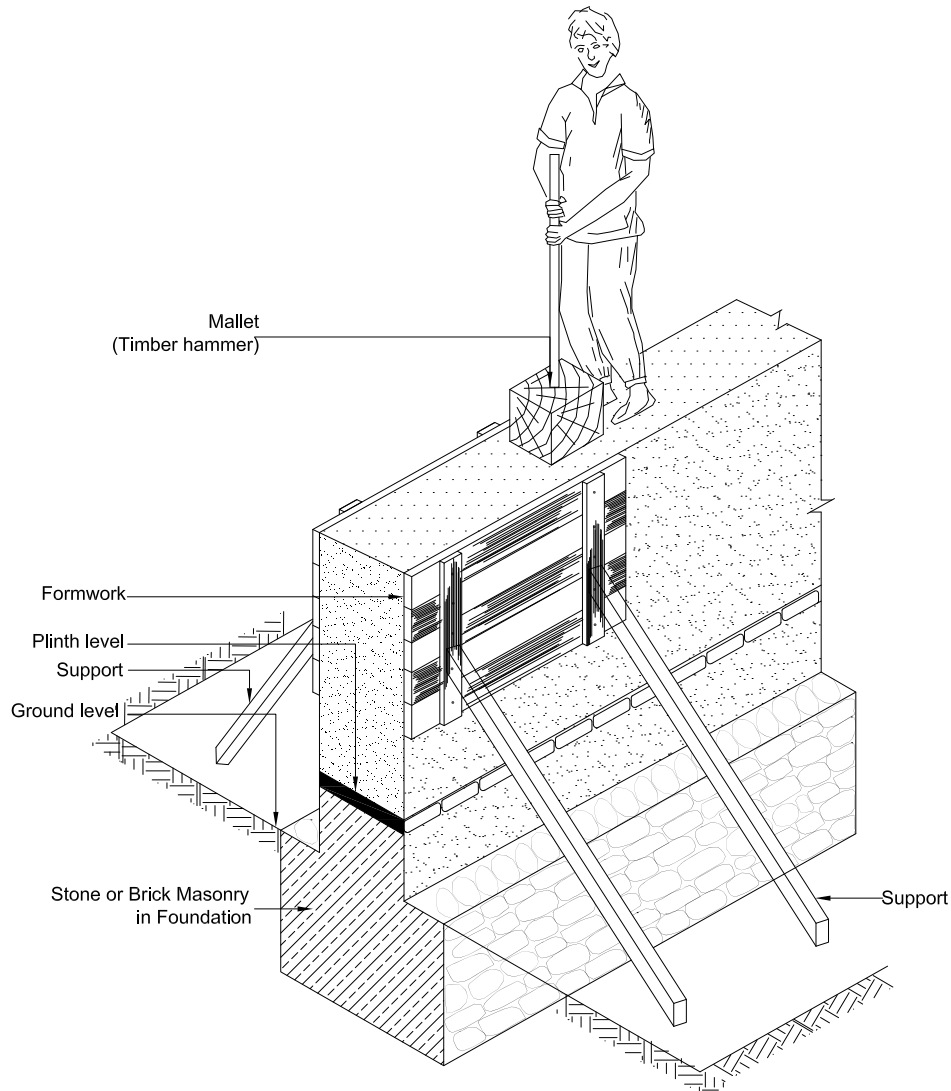

Figure 7.2: Rammed Earth Wall Construction

7.1.3 Adobe (Sun-Dried Bricks/Blocks) Wall Construction

It is better to moisten the bedding surface of the adobe bricks/blocks prior to laying them on the wall. This can be done by placing the bricks/blocks in a flat container with 10 mm deep water in it.

Walls, both in the foundation and the superstructure, shall be true to a plumb line. Mortar packing in the heart of the wall shall not be allowed. The heart shall be well laid with walling units. Mortar joints shall not be more than 20 mm and less than 10 mm in thickness. Vertical joints in alternate layers shall be staggered. The width of the wall shall be uniform. Instead of leaving toothed ends up the same vertical line, stepped construction that allows interlocking between walling units at different vertical sections shall be provided. The details shall be as given in Figure 7.3.

It is preferable to provide horizontal reinforcing bands of bamboo strips at a vertical interval of 450 mm, as detailed in Clause 7.1.1.

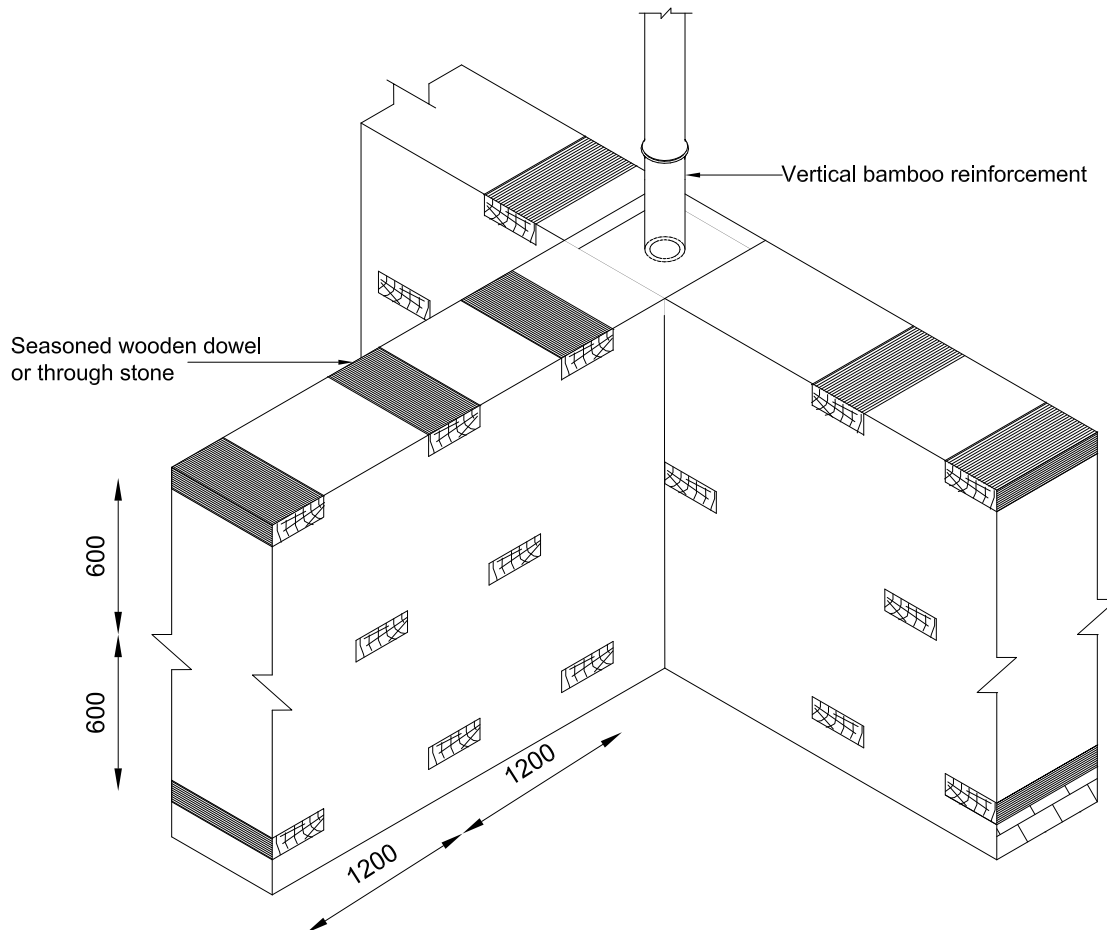

Figure 7.3: Adobe Brick/Block Wall Construction

7.2 Wall Thickness

The minimum thicknesses of different types of mud walls shall be as stated in Table 7.1.

Table 7.1: Minimum Wall Thicknesses for Different Wall Types

WALL TYPE	WALL THICKNESS
Mud Wall	600 – 450 mm *
Rammed-Earth Wall	400 – 450 mm
Adobe Wall	380 – 450 mm

* These wall should be tapered with 600 mm at bottom and 450 at the top

7.3 Unsupported Wall Length

The maximum length of unsupported wall shall not exceed 10 times its thickness. If it is necessary for a wall to be longer than 10 times its thickness, it shall be provided with a buttress at intervals not exceeding 10 times the wall thickness. The details illustrated in Figure 7.4 shall be used for such buttresses.

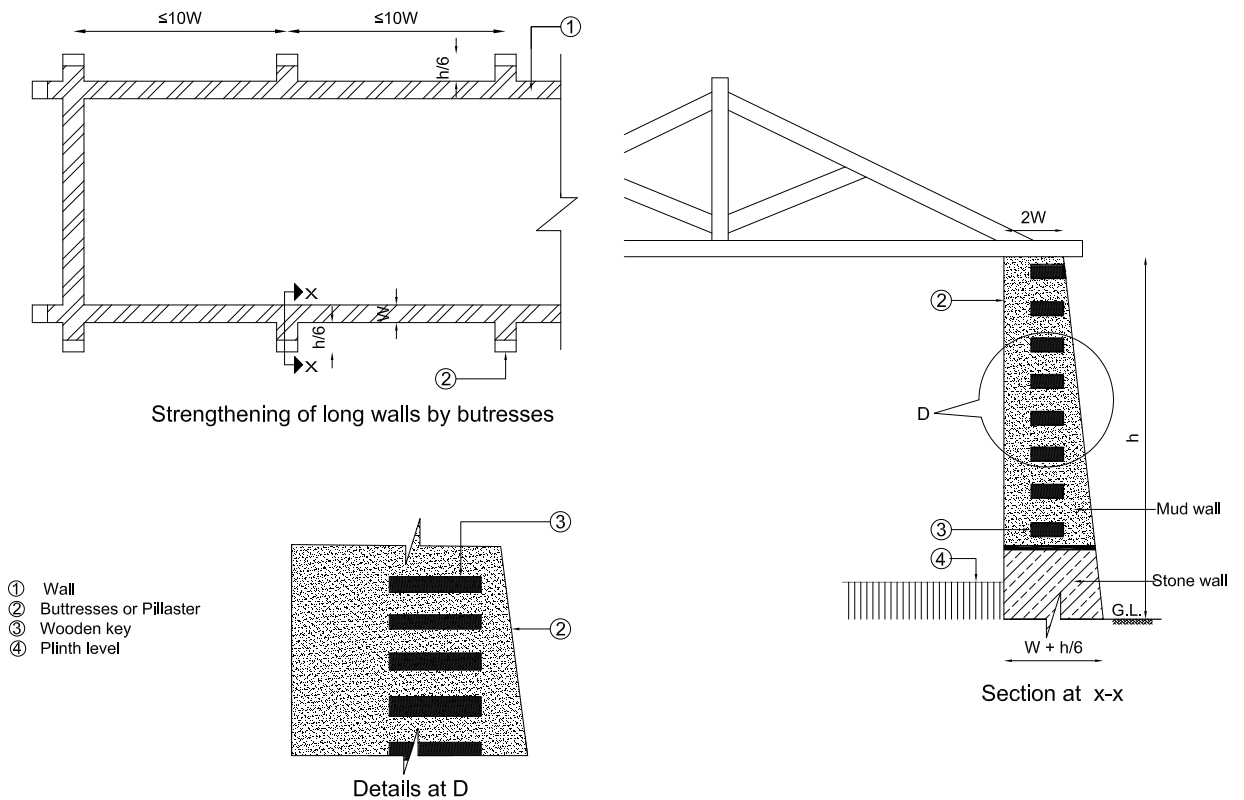

Figure 7.4 : Buttresses on Walls

7.4 Height of Walls

The height to thickness ratio of a wall shall not be more than that 8. However storey height shall be as per clause 5.3.

7.5 Protection of Mud Walls

Damp rising from the ground to the superstructure, the penetration of rain water into the wall from a leaking roof, and the splashing of water during rain, are the major problems which can make mud walls very weak. In order to make mud walls relatively stronger and durable, the following measures shall be adopted.

7.5.1 Foundation

Non-erodible masonry units such as stone, burnt clay bricks or solid blocks shall be used for the foundation and the wall up to plinth level. If it is not possible to make the foundation in non-erodible materials, a dwarf wall shall be made parallel and adjacent to the mud wall, as shown in Figure 7.5. Another problem associated with mud walls is termite attack. Termites bore into timber and bamboo elements and inhabit mud walls. Thus, in areas with a high potential for termite attack, the measures described in Appendix 4 shall be taken to control them.

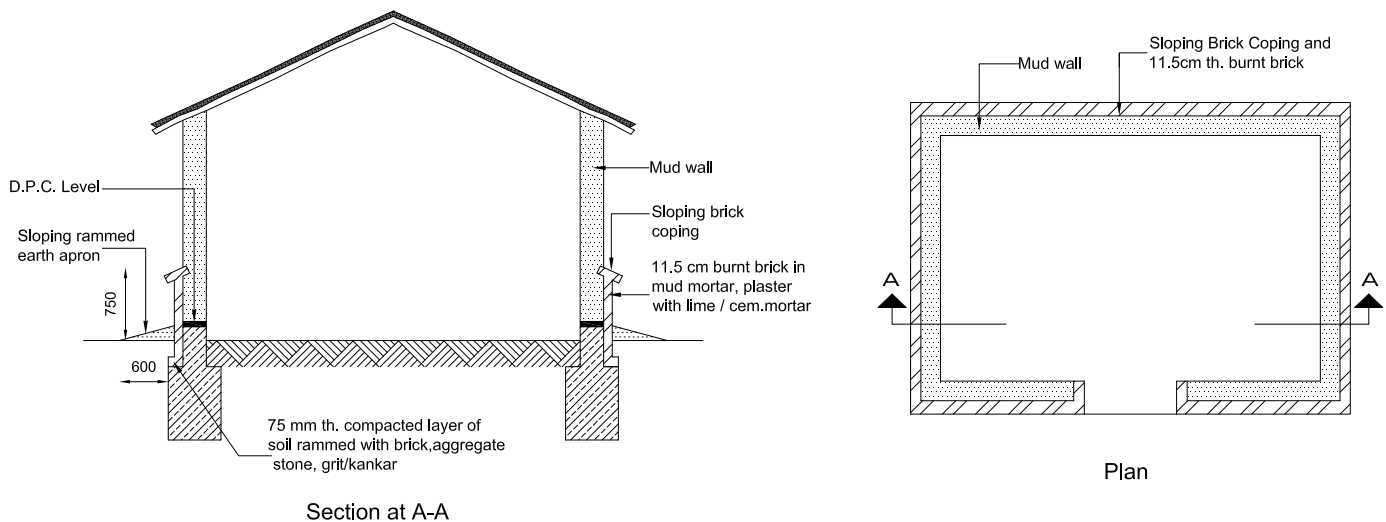

Figure 7.5: Protection of Mud Wall Foundations

7.5.2 Damp Proof Course (DPC)

A layer of DPC shall be laid as described in section 11.1.

7.5.3 Roof Projections

The roof covering shall project at least 600 mm around all the exterior walls.

7.5.4 Non-Erodible Mud Plaster (NEM)

All external wall surfaces shall be plastered with a layer of NEM. The details are given in Appendix 3.

7.6 Corners and Junctions

Corners and junctions of mud walls shall be reinforced vertically and horizontally with timber or bamboo. The details of such reinforcement shall be as illustrated in Figure 7.6.

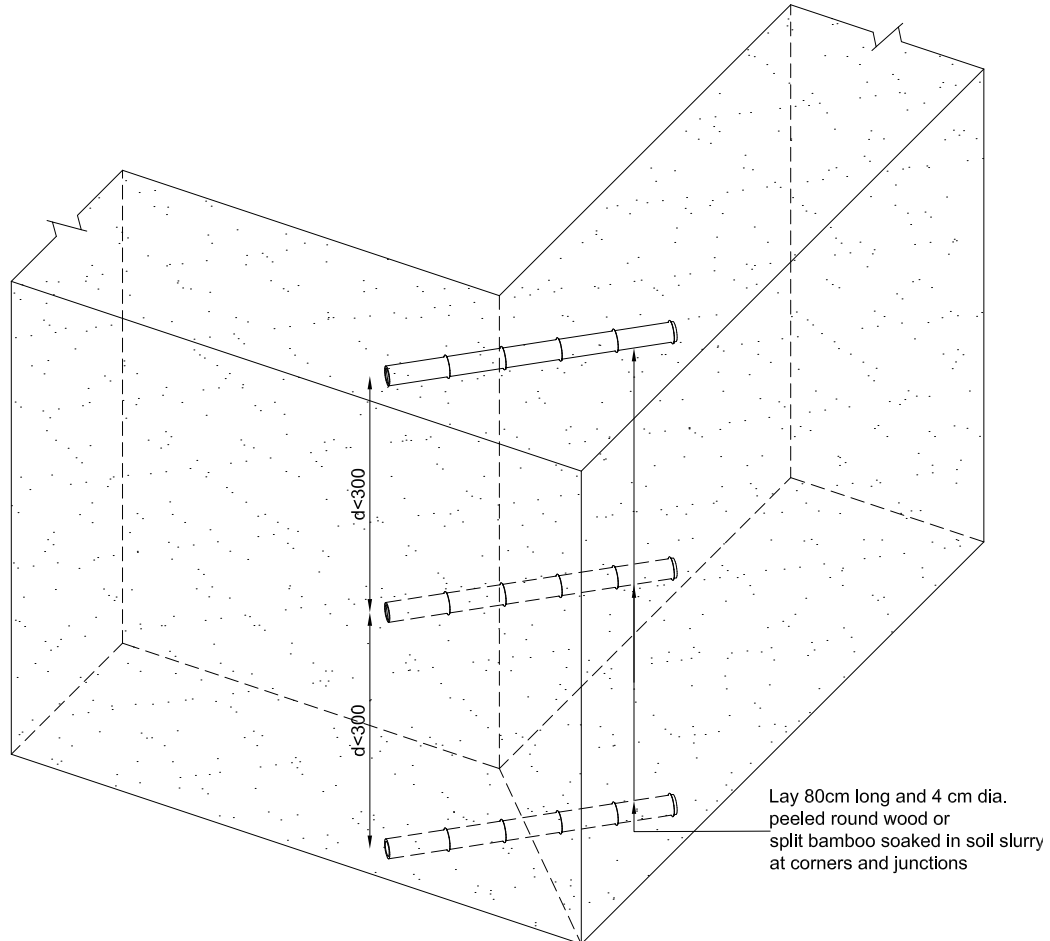

Figure 7.6: Reinforcing of Corners and Junctions of Mud Walls

8 Openings in Walls

Openings in a wall generally describe those for doors and windows. However, the partial puncture of a wall such as that for a wardrobe, for a built-in closet, or for a *Dalan* covered verandah with walls on three sides, shall also be considered as openings in this guideline.

Unbalanced openings contribute to the increased vulnerability of buildings during an earthquake. For buildings to be safer, the sizes and locations of openings shall be controlled as described hereunder.

- a. The total length of the openings on a wall between two consecutive cross-walls shall not exceed 1.2 m.
- b. Only one centrally-located opening on a wall between two consecutive perpendicular walls is preferable.
- c. The vertical distance between two openings shall not be less than 600 mm or half the width of the smaller opening, whichever is greater.
- d. No *Dalan* shall have a wall-to-wall opening. The corners shall be extended at least equal to the wall thickness along the *Dalan* for such openings. The details shall be as presented in Figure 8.1.

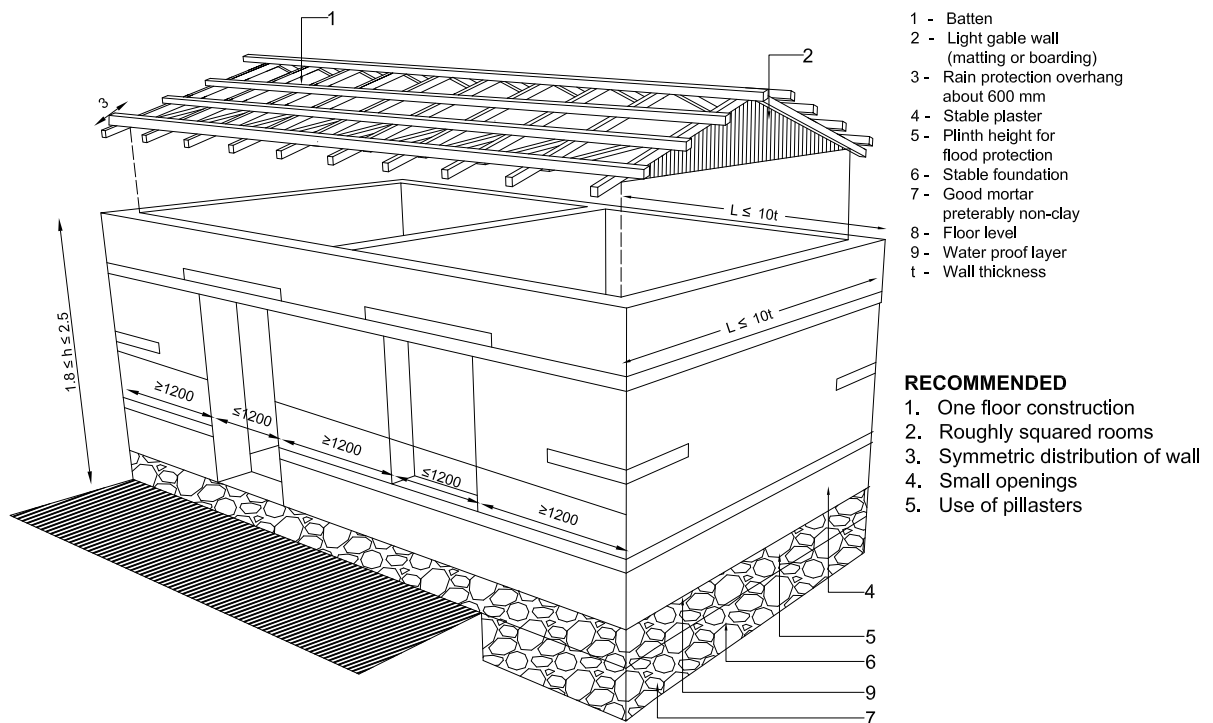

Figure 8.1: Openings for Earthen Buildings

9 Floors and Roofs

Buildings should be as light as possible in order to make them less vulnerable to earthquake. The practice of laying thick layers of mud to achieve a firm floor/flat roof is common. This increases the overall building weight. The thickness of the mud layer used for flooring/roofing shall be kept as small as possible. The roof covering shall project minimum of 450mm around all the exterior walls.

9.1 Structure

The following points shall be duly considered when selecting the materials for flooring structures:

- a. Locally available hardwood species, preferred to soft wood species, shall be used for the structural elements of flooring.
- b. Using a whole tree trunk as a structural element not only increases the weight, but also makes the wood more susceptible to termite attack. This results in a shorter life for such elements. Hence, only sawn timbers shall be used.
- c. Seasoned and treated timber or bamboo shall be used. Simple methods of treating and seasoning timber and bamboo are given in Appendix 1. These shall be carried out prior to the placement of these structural elements.

9.1.1 Posts and Capitals

Circular posts shall be preferred for posts, the whole tree trunk being used only after removal of the bark and the sapwood.

Whenever sawn timber is used for posts, it shall be square in section. The minimum sizes for various posts spacing shall be as tabulated in Table 9.1.

Table 9.1: Size of Posts (mm)

SPECIES	POSTSPACING			
	2 m	2.5 m	3 m	3.5 m
Hardwoods	110x110	110x110	120x120	130x130
Softwoods	120x120	120x120	130x130	140x140

(Note: For circular section, radius(r) is taken equal to the side of square of equal area.)

Each post shall rest on a firm base pad of stone or timber. The base pad shall have a groove in to which the post shall be housed, as shown in Figure 9.1.

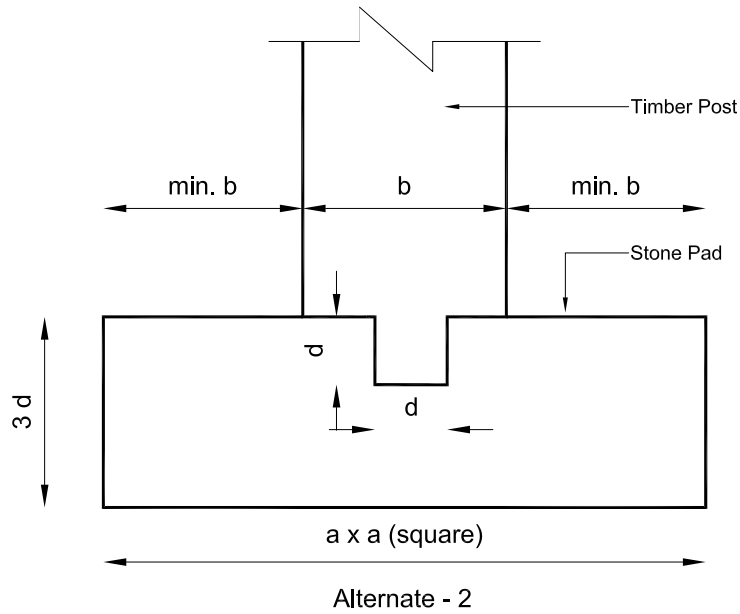
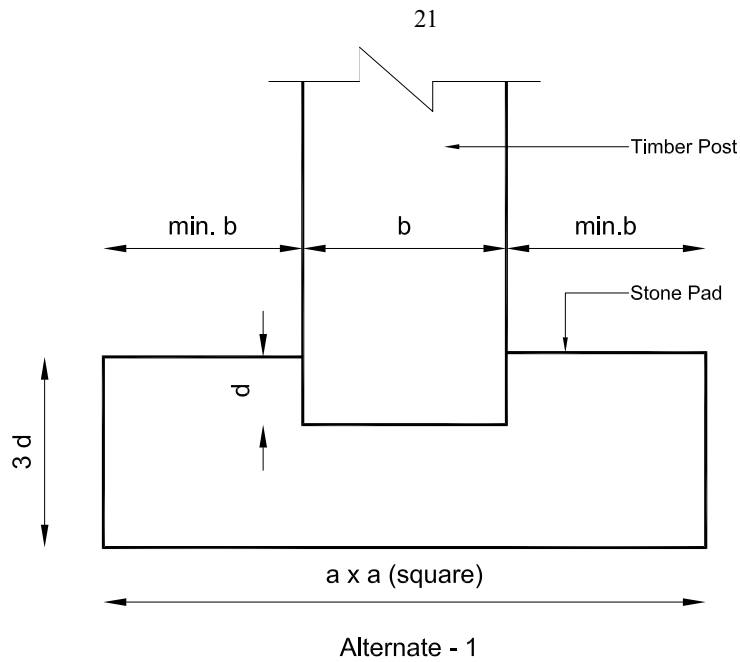

a= 3b or greater
d= b/3 OR 50mm, whichever is maximum
b= size of post

Figure 9.1: Details of Fixing Posts on Base Pads

Whenever a series of posts are erected on the same horizontal line, they shall be founded on a horizontal timber member as shown in Figure 9.2. The minimum depth of such a horizontal timber shall be 75 mm for hardwoods and 100 mm for softwood species. The breadth of these horizontal elements shall not be less than the size of the posts they support.

$1.8 \leq h \leq 2.5$

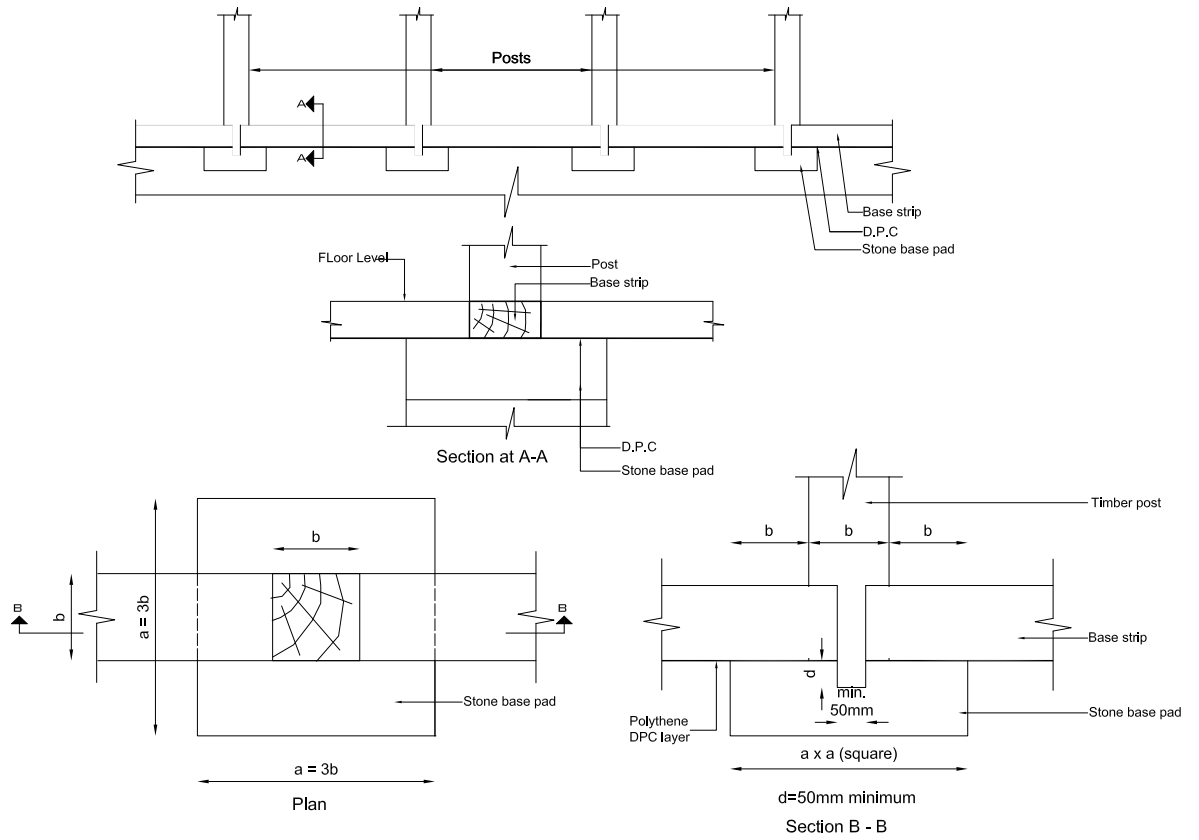

Figure 9.2: Details of Fixing of a Series of Posts on a Base Strip

Each post shall have a properly connected *Meth* (capital) on its top end. The minimum dimensions of such capitals shall be as given in Figure 9.3.

Alternatively, the capitals may be replaced by struts well-connected to the posts and beams, as shown in Figure 9.4.

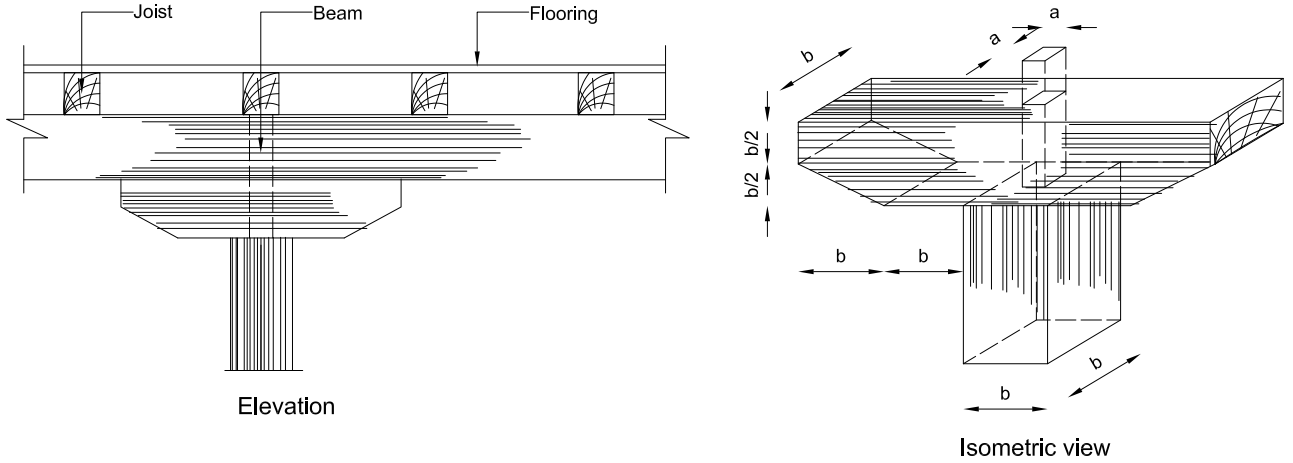

Figure 9.3: Details of Fixing Capitals on the Posts

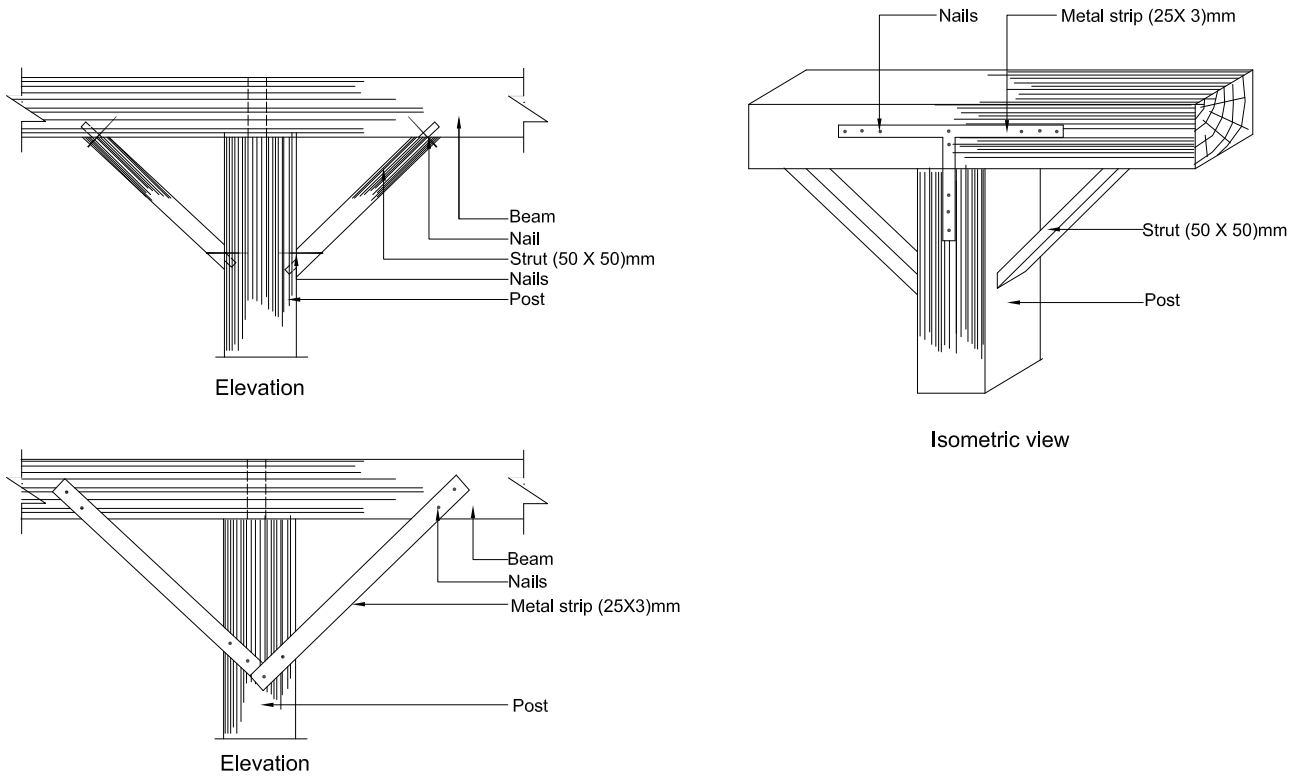

Figure 9.4: Alternative Details for Fixing Struts on Posts and Beams

9.1.2 Beams and Bearings

Beams shall never rest directly on a wall. A base pad for the beam shall be provided. This pad should be either of timber or a large flat stone covering the whole width of the wall. The minimum thickness of such a pad shall be 75 mm.

The beam shall be long enough to extend beyond both the supporting walls. Timber keys shall be provided on both the external and internal walls as shown in Figure 9.5.

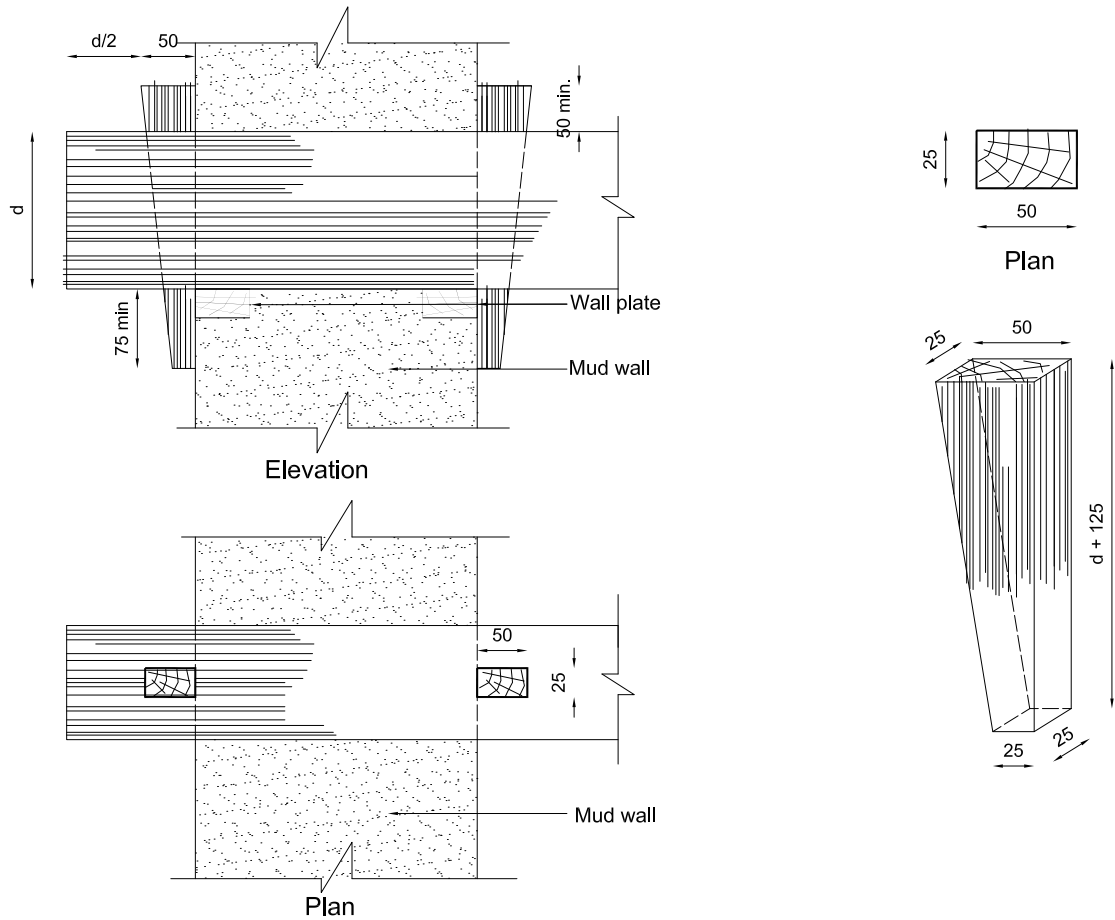

Figure 9.5: Details of Fixing Keys on Beams

The beams shall be rectangular in section and shall never be laid wider surface horizontal. The minimum dimensions of the beams for different spans shall be as tabulated in Table 9.2.

Table 9.2: Size of Beams (mm) for Various Spans

SPECIES	Size (DxB) for SPAN of			
	2 m	2 to 2.5 m	2.5 to 3 m	3 to 3.5 m
Hardwood	190x100	220x100	240x120	270x140
Softwood	230x120	270x140	310x150	340x160

9.1.3 Wall Plates

Wall plates or horizontal bands shall extend all around the walls. They shall be placed on the wall so that the joists rest on them. The fixing details and minimum dimensions of such wall plates and or bands shall be (100mmx75mm) as given in Figure 9.6.

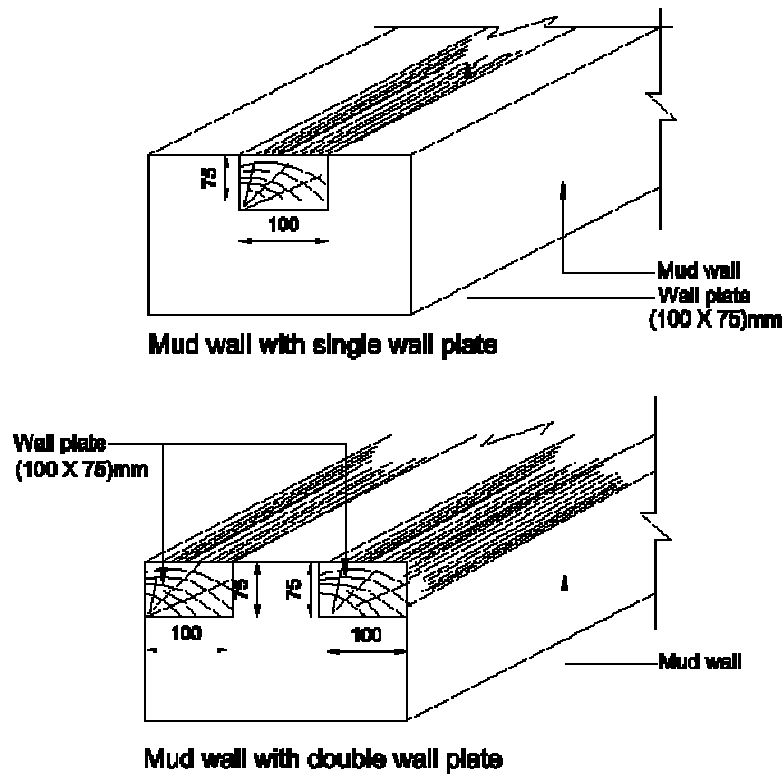
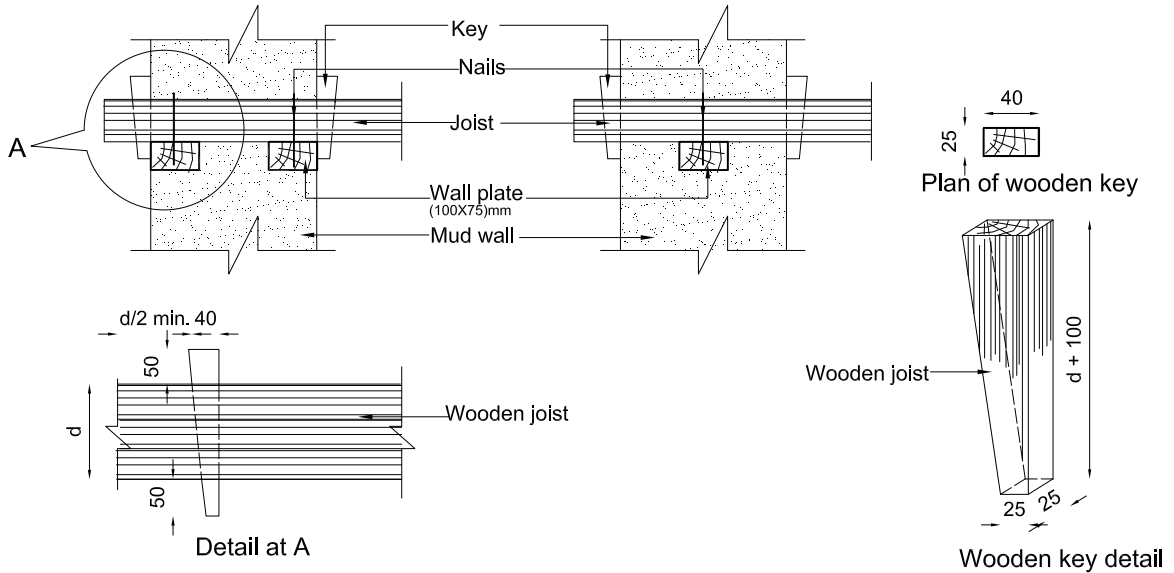

Figure 9.6: Details for Fixing Wall Plates

9.1.4 Joists and Rafters

Joists/rafters shall be long enough to extend beyond supporting members such as walls and/or beams. The extended joists/rafters shall have timber keys on both external and internal sides of the supporting elements as shown in Figure 9.7.



Fixing of joists

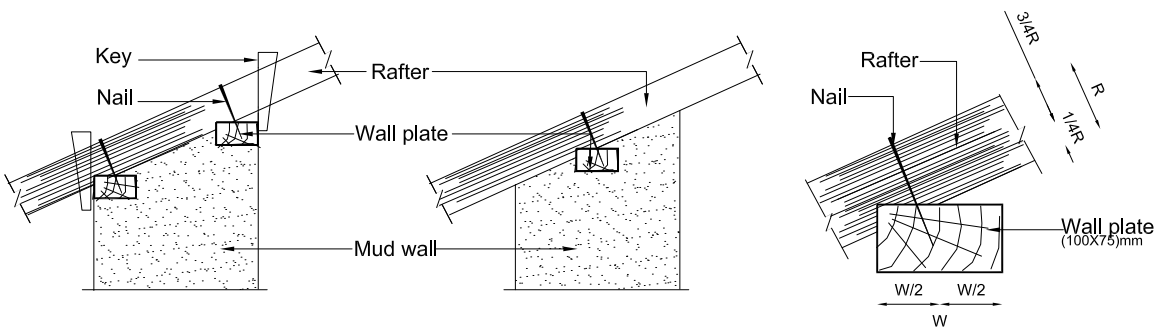

Fixing of rafters to wall plate

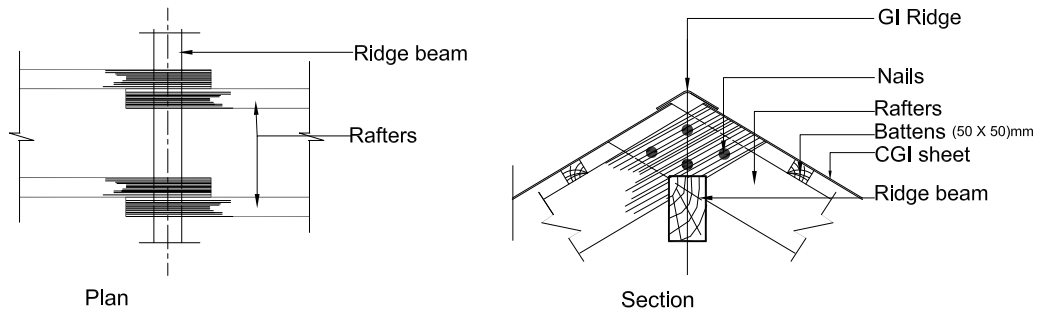

Fixing of rafters to ridge

Figure 9.7: Details for Fixing Joists and Rafters

The joists/rafters shall be rectangular in section and shall never be laid with their wider surface horizontal. The minimum sizes of joists/rafters for various spans considering 1" plank shall be as tabulated in Table 9.3.

Table 9.3: Minimum Size (mm) of Joists and Rafters

SPECIES	Dimension (DxB) FOR SPAN UPTO				
	1 m	1.5 m	2 m	2.5 m	3 m
Hardwood	100*65	100*65	100*65	120*65	130*75
Softwood	140*75	140*75	140*75	170*90	180*90
Spacing (c/c)	≤0.5m	≤0.5m	≤0.5m	≤0.5m	≤0.5m

9.2 Floor Finishing and Roof Coverings

9.2.1 Bridging Materials

Using better bridging materials allows joists to be spaced wider apart which will not only reduce the construction cost, but also make the building lighter. If chopped (split) wood or planks are used as bridging materials, they shall be nailed to each joist supporting them. If bamboo, reed, or any other material is used, it also shall be tied to the joists. Some of the simple connecting details for such materials are illustrated in Figure 9.8.

Half-cut bamboo placed as an inverted "U" over the joists makes the best low-cost bridging material.

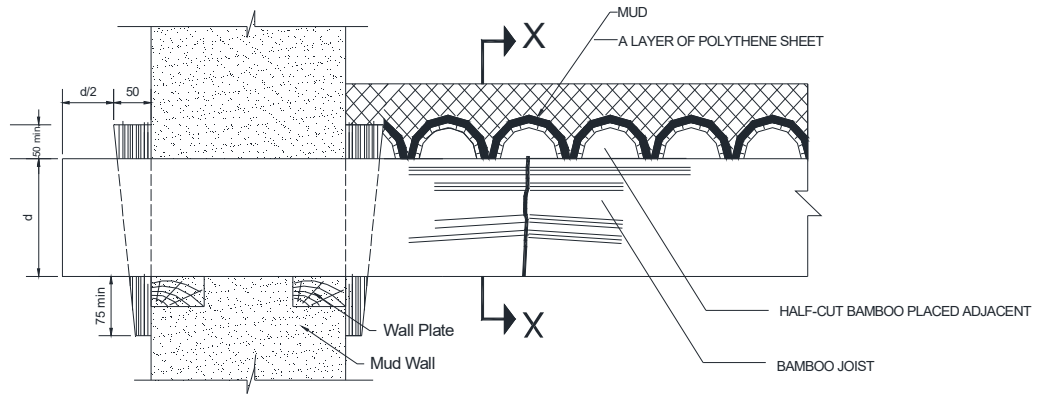

ELEVATION

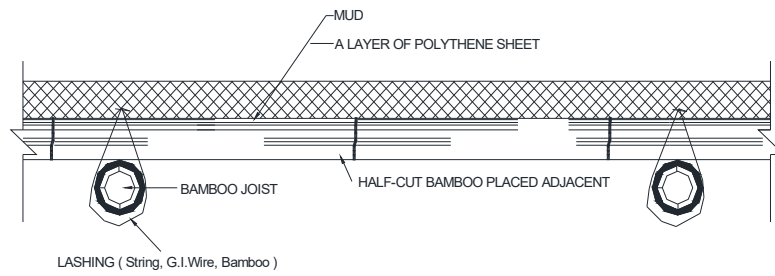

SECTION AT X-X

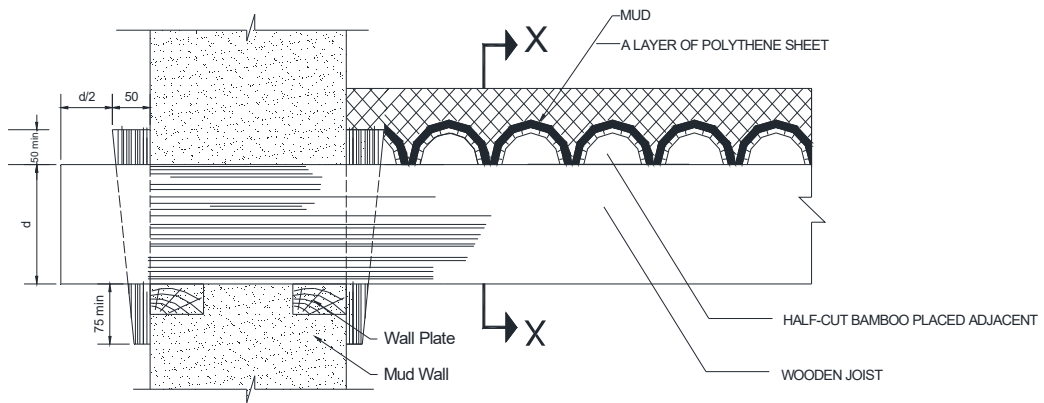

ELEVATION

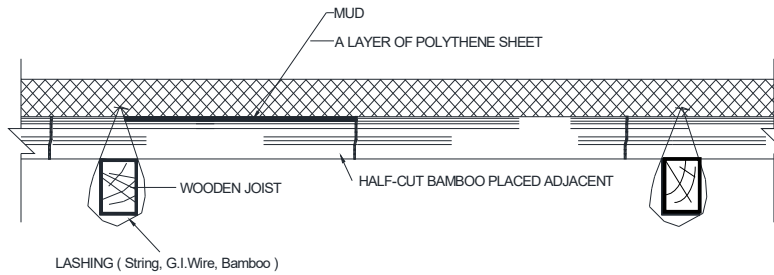

SECTION AT X-X

Figure 9.8: Details for Fixing Bridging Materials to Joists and Rafters

9.2.2 Floor Finishing

It is preferable to use better bridging materials between the joists to achieve a stiffer flooring. Timber planks and half-cut bamboo are examples of these. The fixing shall be carried out as illustrated in Figure 9.8.

The mud layers used for the floor base and the finish shall not be more than 75 mm thick in total.

9.2.3 Roof Covering

Stone slabs, slates and mud roofing make a building heavy. These elements should be avoided as far as practicable. Tiles or *jhingati* laid over a mud layer are another load-increasing factor and should be avoided. However, it may not be possible to avoid completely these elements owing to various constraints. Lighter options such as thin stone slabs and a thinner layer of mud are preferable.

9.2.3.1 Mud

Mud is widely used in the north-western parts of Nepal. The general techniques practised for making mud roofs consume high quantities of mud, resulting in heavy buildings. Mud roofs shall be constructed as illustrated in Figure 9.9.

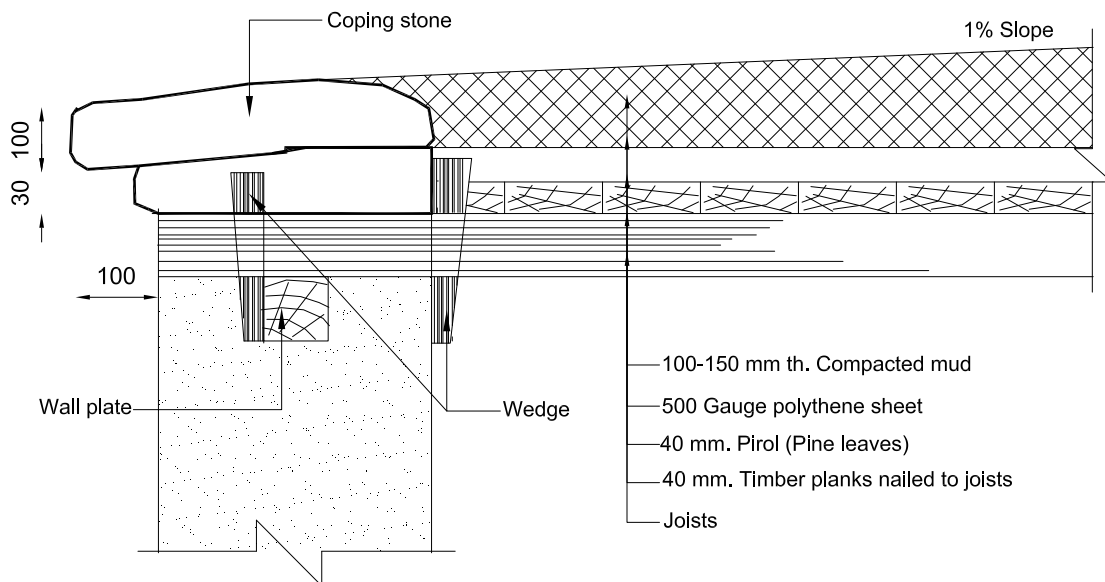

Figure 9.9: Details of Improved Mud Roofing

9.2.3.2 Thatch

Thatch is the lightest of all materials used for roof covering. A shorter life-span, leaking and vulnerability to fire are the main deficiencies of thatch which lead builders to opt for a better material. There are techniques available for making thatch durable and fire-retarding. Hence, improved thatch roofing shall be preferred to heavier materials such as stone slabs or slates. Thatched roofs shall be constructed as illustrated in Figure 9.10. Thatched roofs shall be made fire-retarding and water-repelling by methods given in Appendix 2.

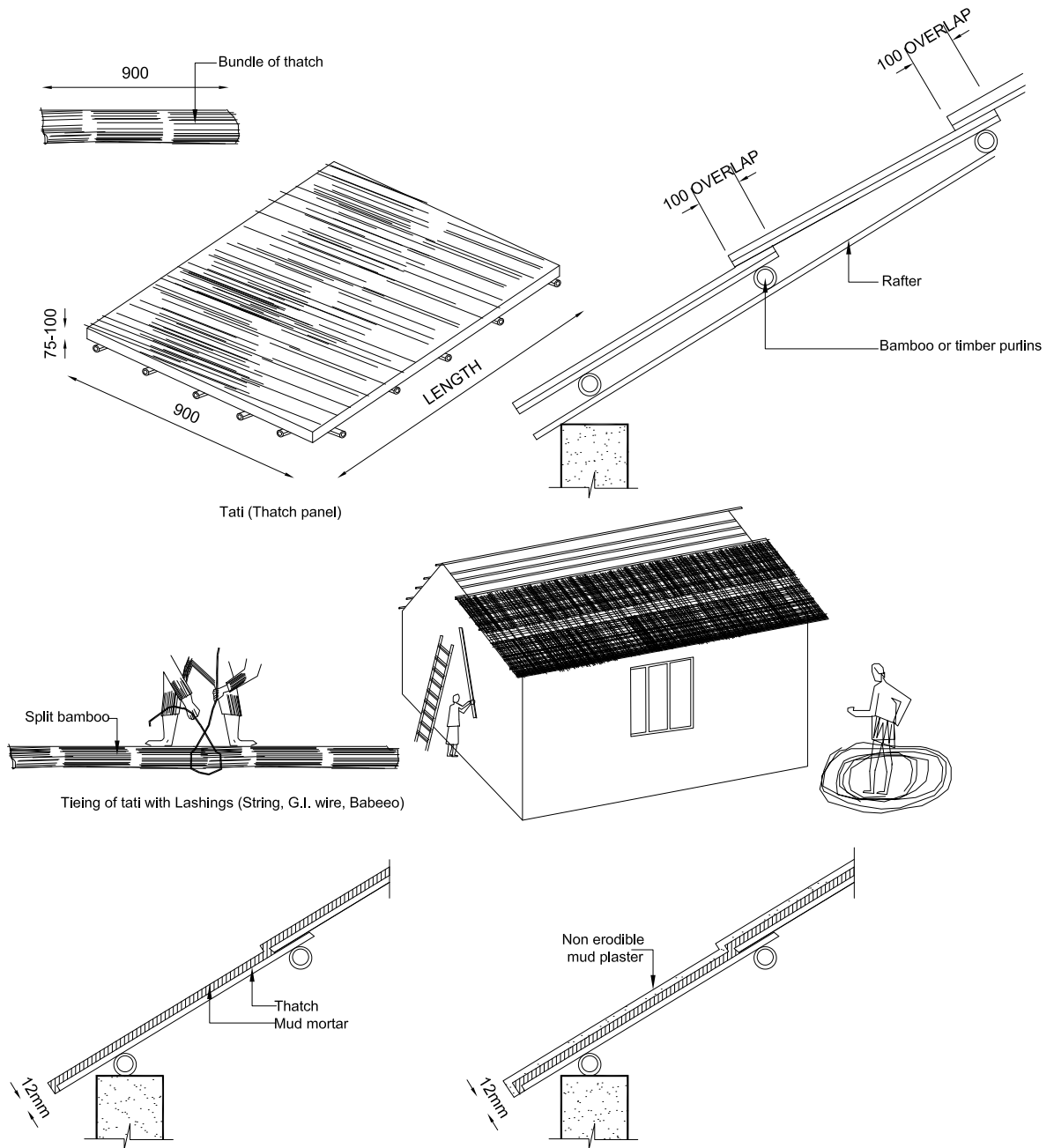

Figure 9.10: Details of Improved Thatched Roofing

9.2.3.3 Slates

Thin slates shall be preferable to thicker ones. Slates shall be of uniform size. They shall be nailed to purlins and laid with a minimum overlapping of 75 mm to prevent leaking. The details illustrated in Figure 9.11 shall be adopted for slate roofing.

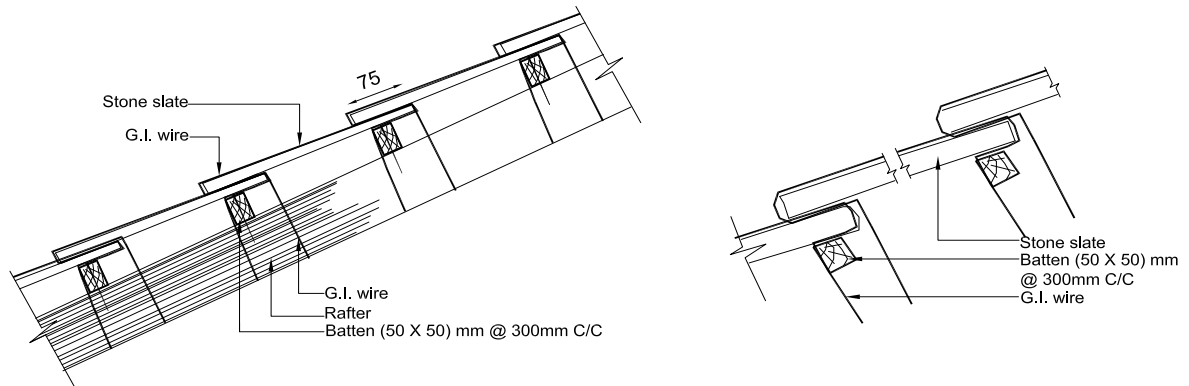

Figure 9.11: Details for Laying Slate

9.2.3.4 Clay Tiles

Well-burnt, good-quality clay roofing tiles shall be used for roofing. All the tiles shall be well-anchored on the battens. The details given in Figure 9.12 shall be adopted for fixing clay tiles.

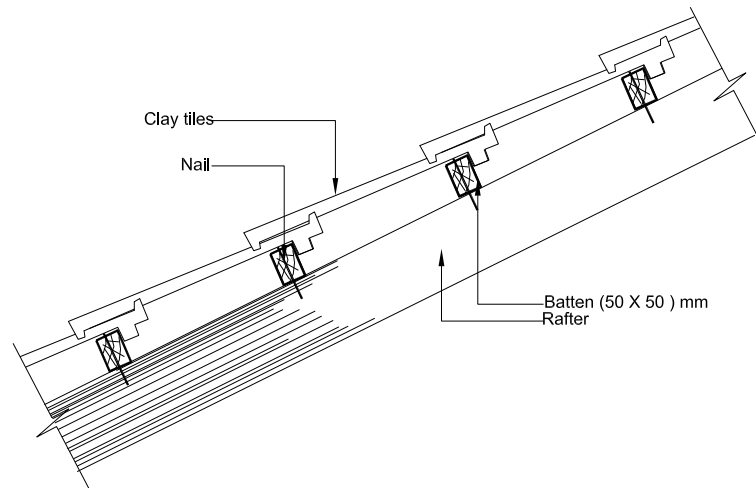

Figure 9.12: Details of Fixing Clay Tiles

9.2.3.5 MCR Tiles

Micro concrete roofing (MCR) tiles are becoming popular in many parts of the country. These tiles have projected binding wires embedded into the tiles for anchoring. All the tiles shall be properly tied with these protruding wires to the battens and purlins, as shown in Figure 9.13.

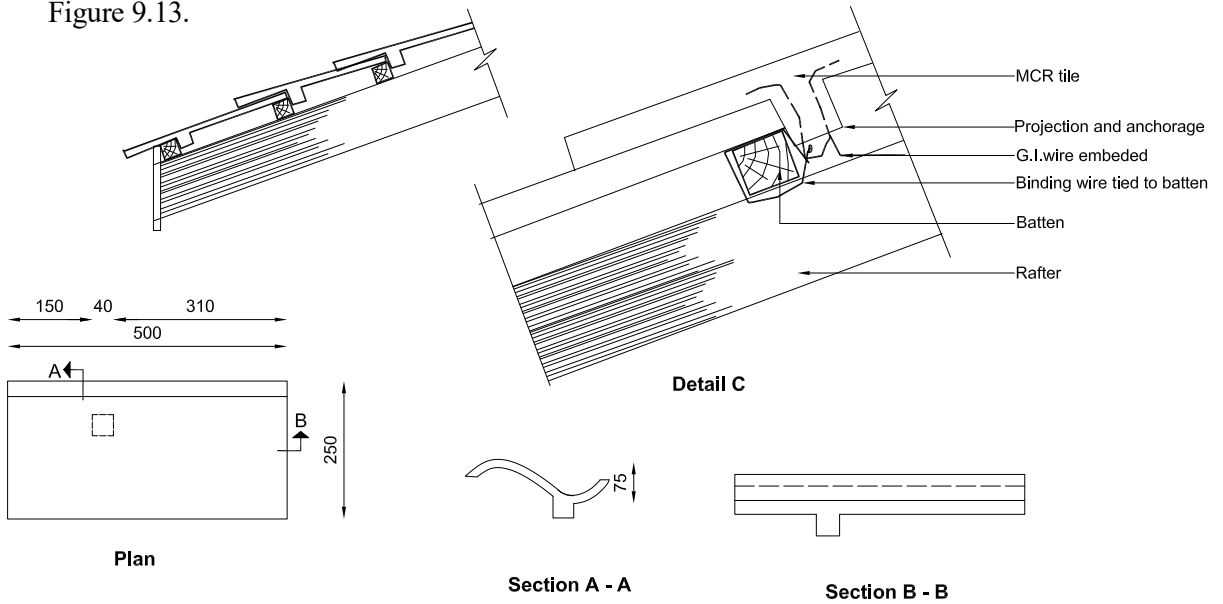

Figure 9.13: Details for Fixing MCR Tiles

9.2.3.6 CGI Sheets

Corrugated galvanised iron (CGI) sheets are very popular in all parts of the country, except in the high mountains. These sheets shall be properly anchored to each purlin/batten that supports them. The details are illustrated in Figure 9.14.

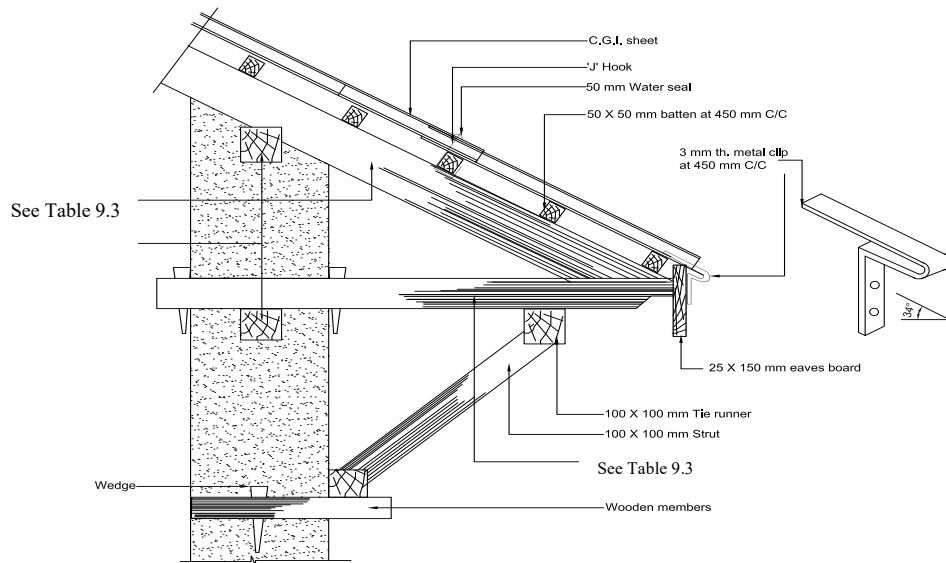

Figure 9.14: Details for Fixing CGI Sheets

9.3 Bamboo for Flooring and Roofing

Only treated bamboo shall be used for structural elements. The bamboo shall be straight and uniform without any defects.

9.3.1 Bamboo Flooring

Bamboo flooring shall be made as illustrated in Figure 9.15.

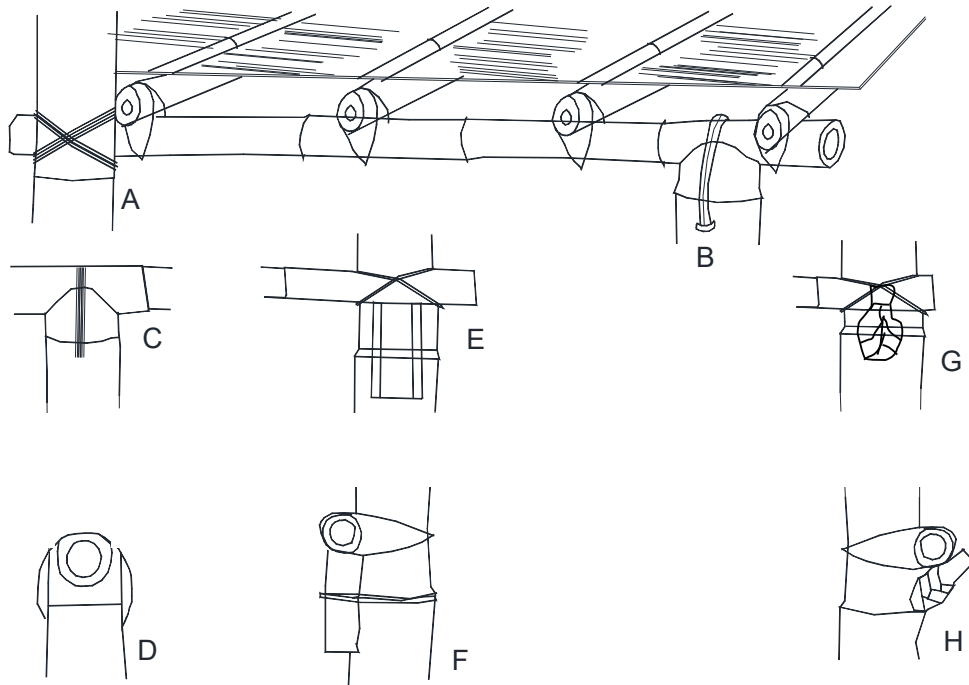

- A, FITTING AND BINDING CULMS AT JOINTS IN ROOF AND FRAME
 B, FITTING AND SECURING BAMBOO BOARDS OF FLOOR
 C,D, SADDLE JOINT
 E,F, USE OF INSET BLOCK TO SUPPORT HORIZONTAL LOAD BEARING ELEMENTS
 G,H, USE OF STUMP OF BRANCH AT NODE OF POST TO SUPPORT HORIZONTAL LOAD BEARING ELEMENTS

Figure 9.15: Details of Bamboo Flooring

9.3.2 Bamboo Roofing

Bamboo roofing can be made in two ways. The first method is for a simple roof, the details of which shall be made as illustrated in Figure 9.16.

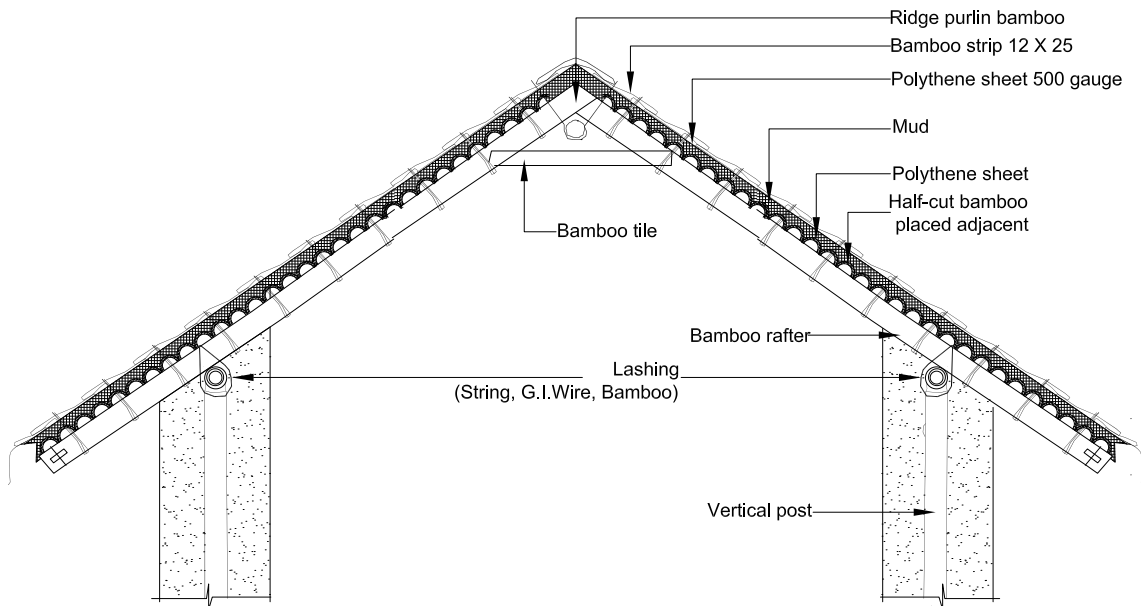

Figure 9.16: Details of Simple Bamboo Roofing

The second method involves making a simple truss out of bamboo. The construction of bamboo trusses shall be as illustrated in Figure 9.17

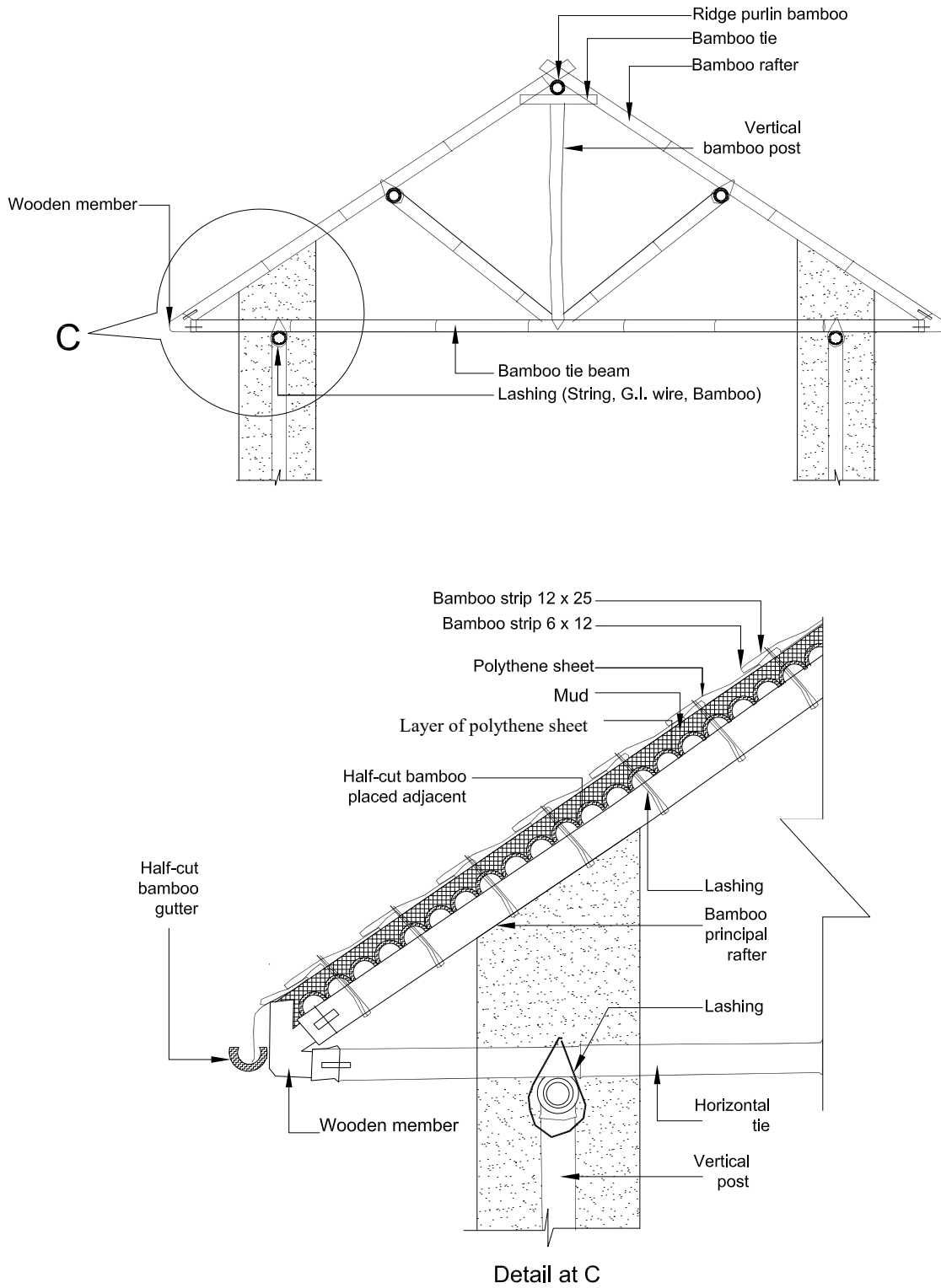

Figure 9.17: Details of Trussed Bamboo Roofing

10 Seismic-Resistant Components

There are number of components which contribute to an enhanced safety against earthquake forces. These elements shall be incorporated in all buildings. The details are given hereunder.

10.1 Vertical Reinforcement

No mud wall shall be constructed without vertical reinforcement. The materials used for vertical reinforcement shall depend upon the availability of suitable materials in the locality. Bamboo is potential material for vertical reinforcement. Timber can also be used. The details for using each of these materials as vertical reinforcement shall be as presented hereunder.

Vertical reinforcement shall be located at all corners and junctions of a wall. It shall start from the foundation and be continued to the roof band.

10.1.1 Bamboo

The details for using bamboo as vertical reinforcing shall be as illustrated in Figure 10.1.

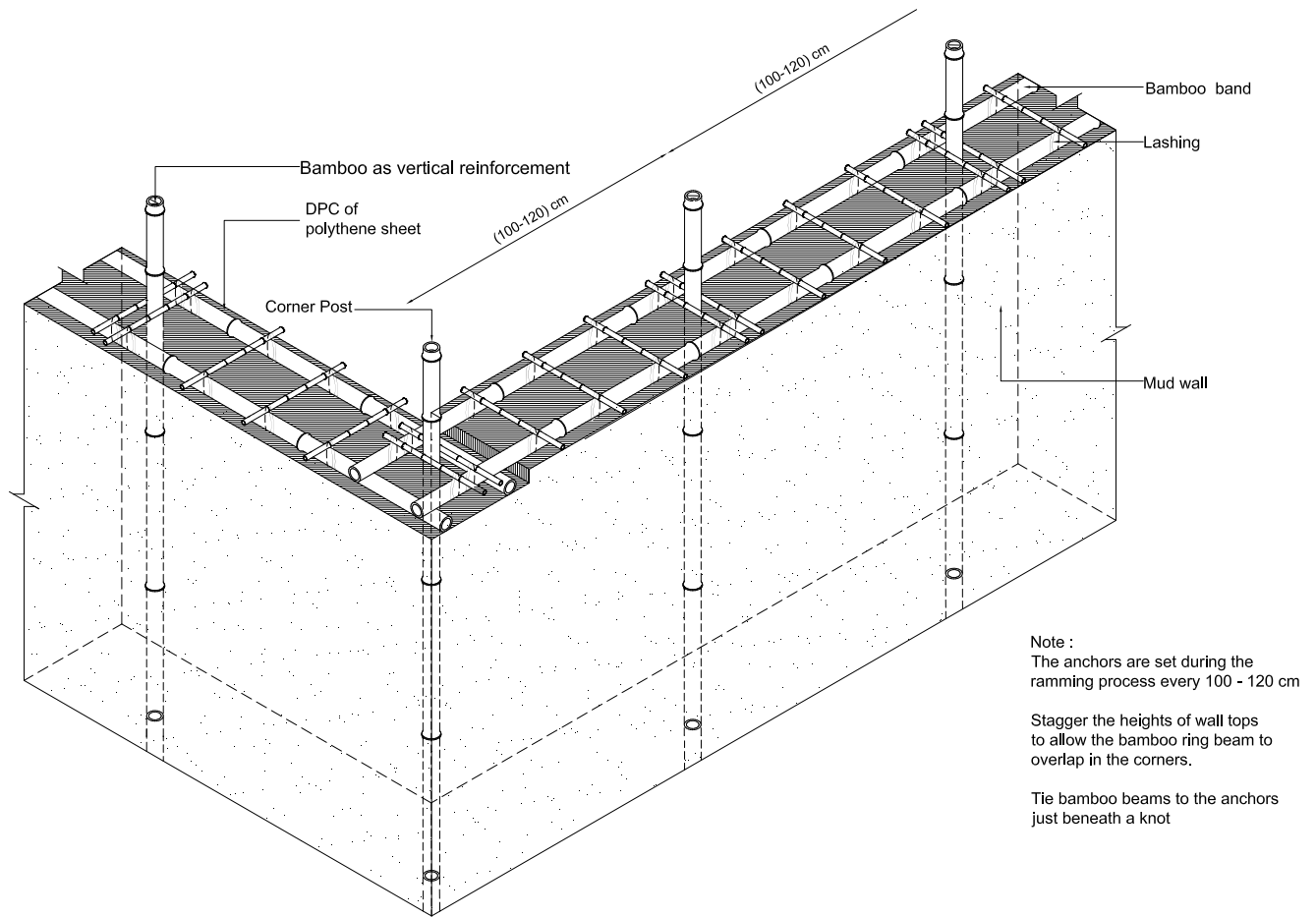

Figure 10.1: Bamboo as Vertical Reinforcement.

10.1.2 Timber

It is difficult to find a single stick of timber long enough to span between the foundation and the roof. Dovetail joints shall be used to connect the different timbers to form a single unit. The details of providing such vertical reinforcement shall be as illustrated in Figure 10.2.

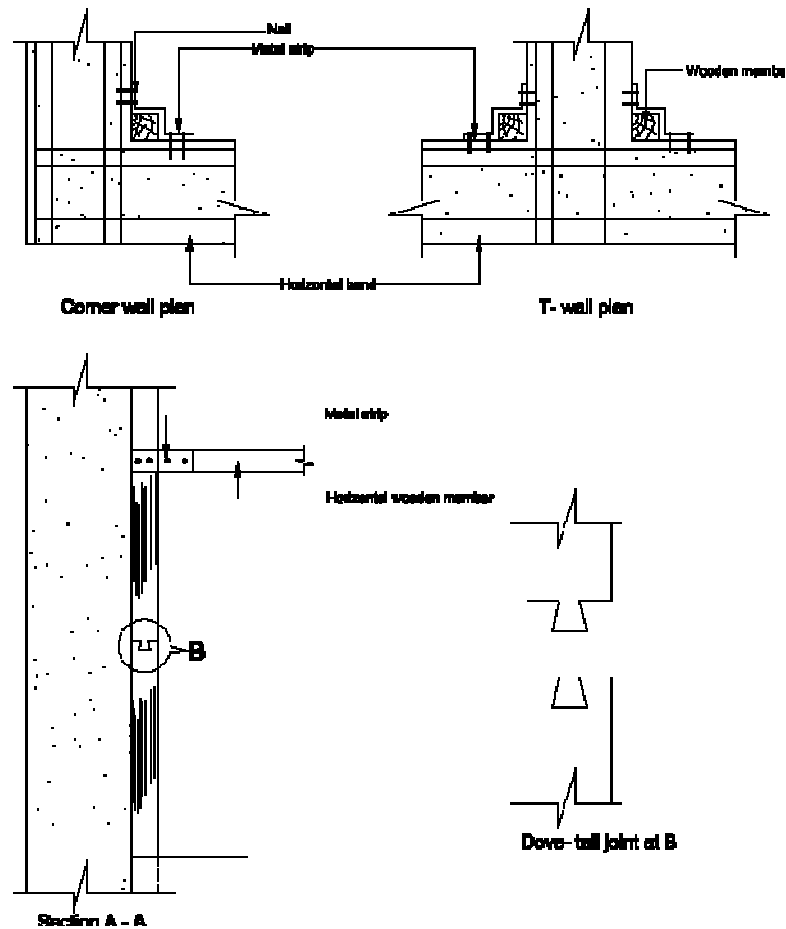

Figure 10.2: Timber as Vertical Reinforcement

10.2 Horizontal Bands

Horizontal bands are pre provided to create box effects and to impart horizontal bending strength in them. Therefore, Bamboo and timber should be used as horizontal bands. Such bands shall be located at least at the plinth, sill and lintel levels of the building. They shall be made continuous throughout the length of the wall with proper connections, and they shall be tied properly with the vertical bands at different levels. Details of the use of various materials for these horizontal bands are given below.

10.2.1 Bamboo Bands

An assemblage of two parallel bamboo lengths connected by struts shall be made wide enough to cover the entire thickness of the wall to create a horizontal band. The details for constructing such a band shall be as illustrated in Figure 10.3.

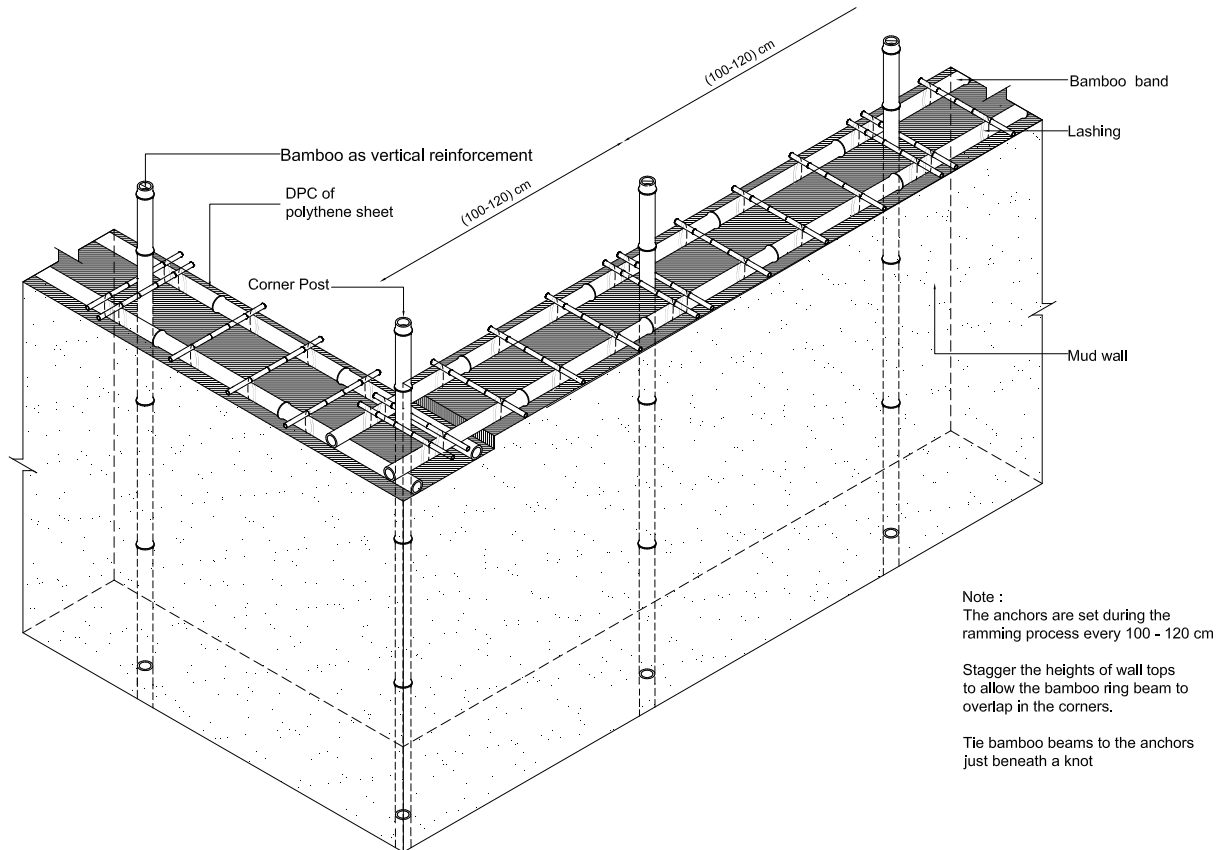

Figure 10.3: Bamboo for Horizontal Bands

10.2.2 Timber Bands

A timber band can be constructed in a similar manner to the bamboo band. The details shall be as illustrated in Figure 10.4.

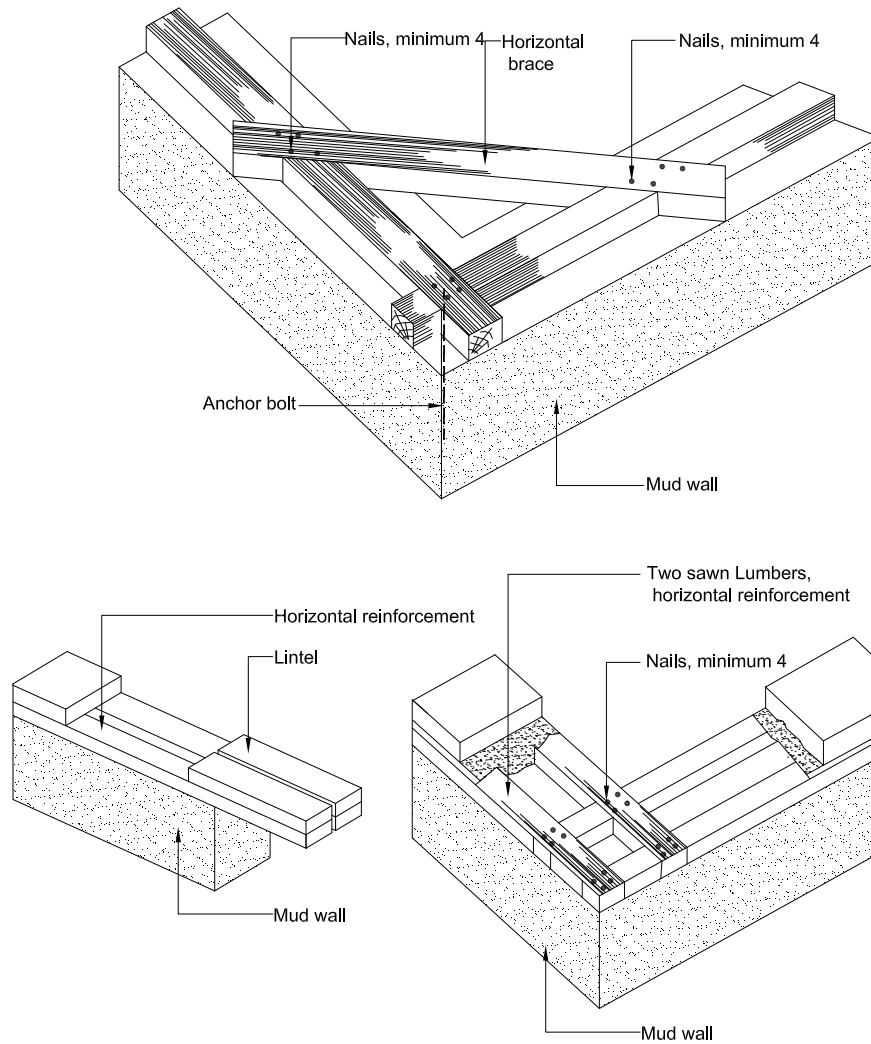
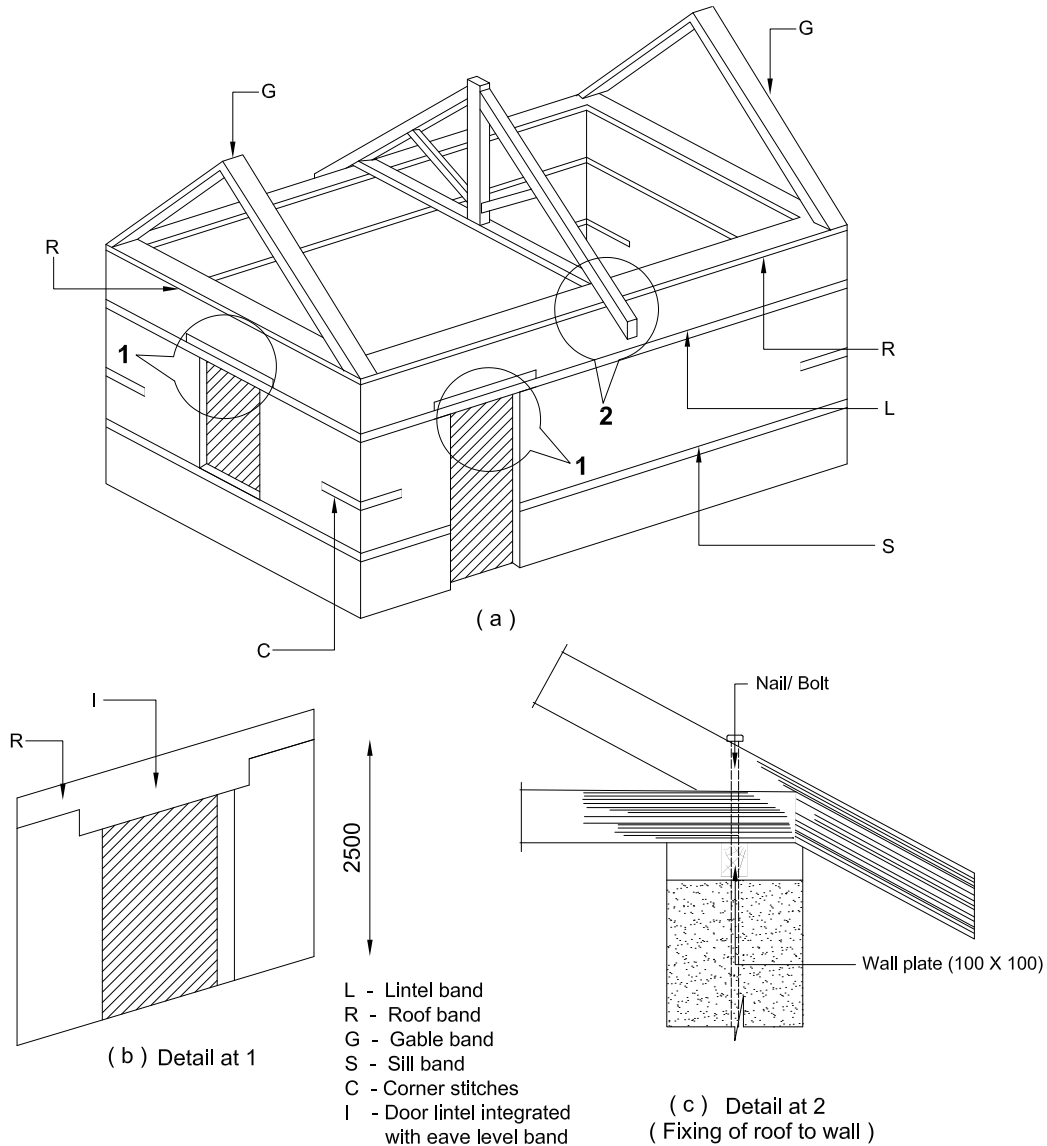

Figure 10.4: Timber for Horizontal Bands

10.3 Gable Bands

Gable bands must be used in all sloped-roof construction. They are constructed in a similar manner to horizontal bands. The difference is their position in the buildings. Gable bands are inclined members placed parallel to the inclination of the gable wall forming the roof slope. The details shall be as illustrated in Figure 10.5.



Note:

- i) As an alternative to the gable masonry, a truss or open gable may be used and the openings covered with a light material such as sheeting, matting etc.
- ii) If the wall-height up to eave-level is less than or equal to 2.5 m, the lintel-level band may be omitted and the lintel integrated with the eave-level band as shown in Detail 2.

Figure 10.5: Details for Gable Bands

10.4 Diagonal Bracing

All flexible structural elements such as joists and rafters shall be diagonally braced. Each crossing of a joist/rafter and a brace shall be properly fixed. The bracing material could be timber strips, whole bamboo, or bamboo strips. The details shall be as illustrated in Figure 10.6.

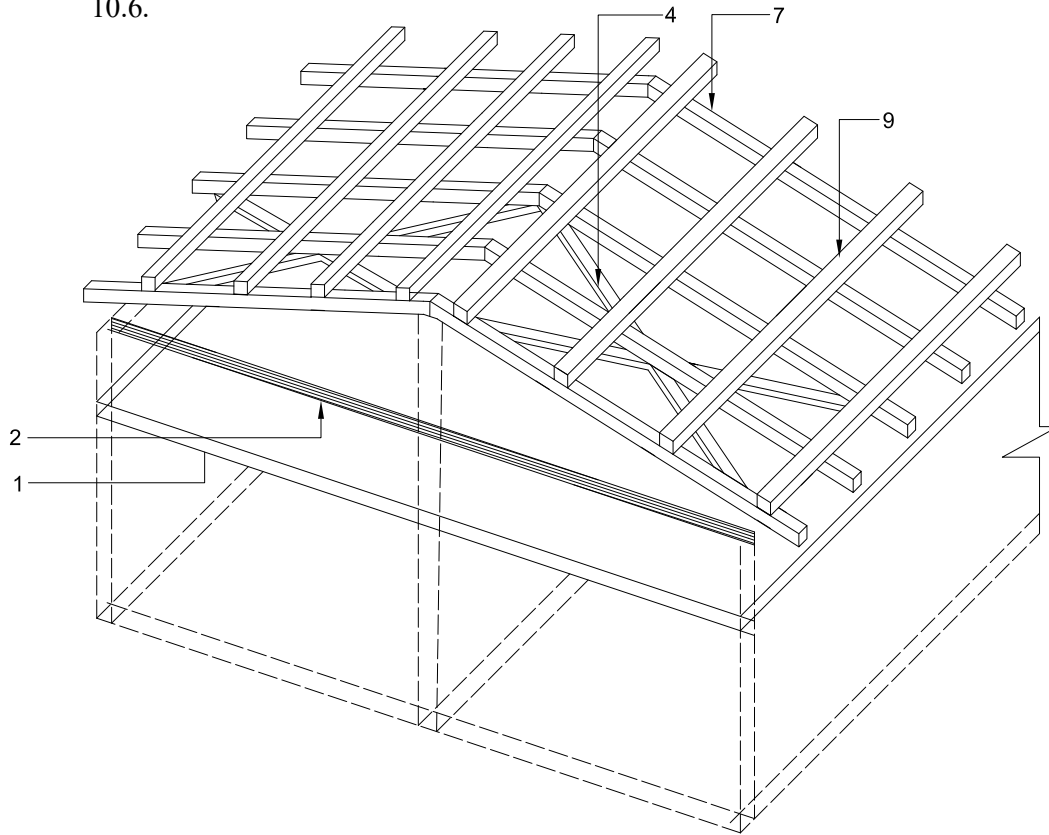

Details of roof members with bracing

1. Floor
2. Gable wall (tympanum)
3. Wooden nail nailed to new ties 5 and 2
4. Planks, Diagonal bracing
5. Planks, Ties
6. Roof covering
7. Roof rafters
8. Gable wall to be filled with lighter Materials
9. Purlin

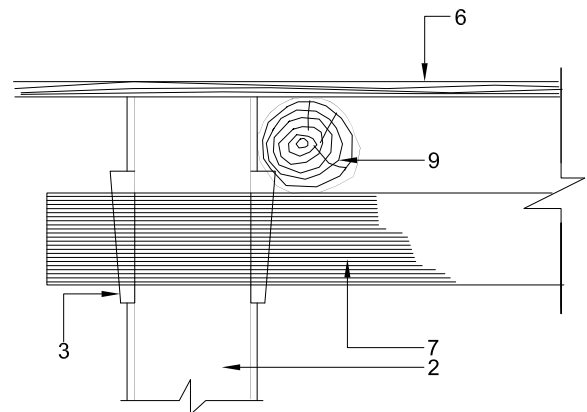

Figure 10.6: Details for Diagonal Bracing

10.5 Lateral Restrainers

When joists and beams are placed as detailed in section 9.1.2 and 9.1.4, the timber keys, along with the beams and rafters, work as lateral restrainers. Since they are effective in only one direction, only the walls normal to them are laterally restrained. For restraining the walls parallel to the joists, the wall plates and horizontal bands shall be extended beyond the exterior of walls to facilitate anchoring them by timber keys. This will partially restrain the walls parallel to the joists. Additionally, timber members having the same cross-sectional areas as the joists shall be placed underneath joists and normal to them. These elements shall be long enough to be extended beyond the wall on the external side and at least across two joists on the internal surface. These elements shall be nailed to the joists and timber keys shall be provided on both the internal and external faces of the wall. These timber elements shall have a maximum spacing of 450 mm. The details shall be as given in Figure 10.7.

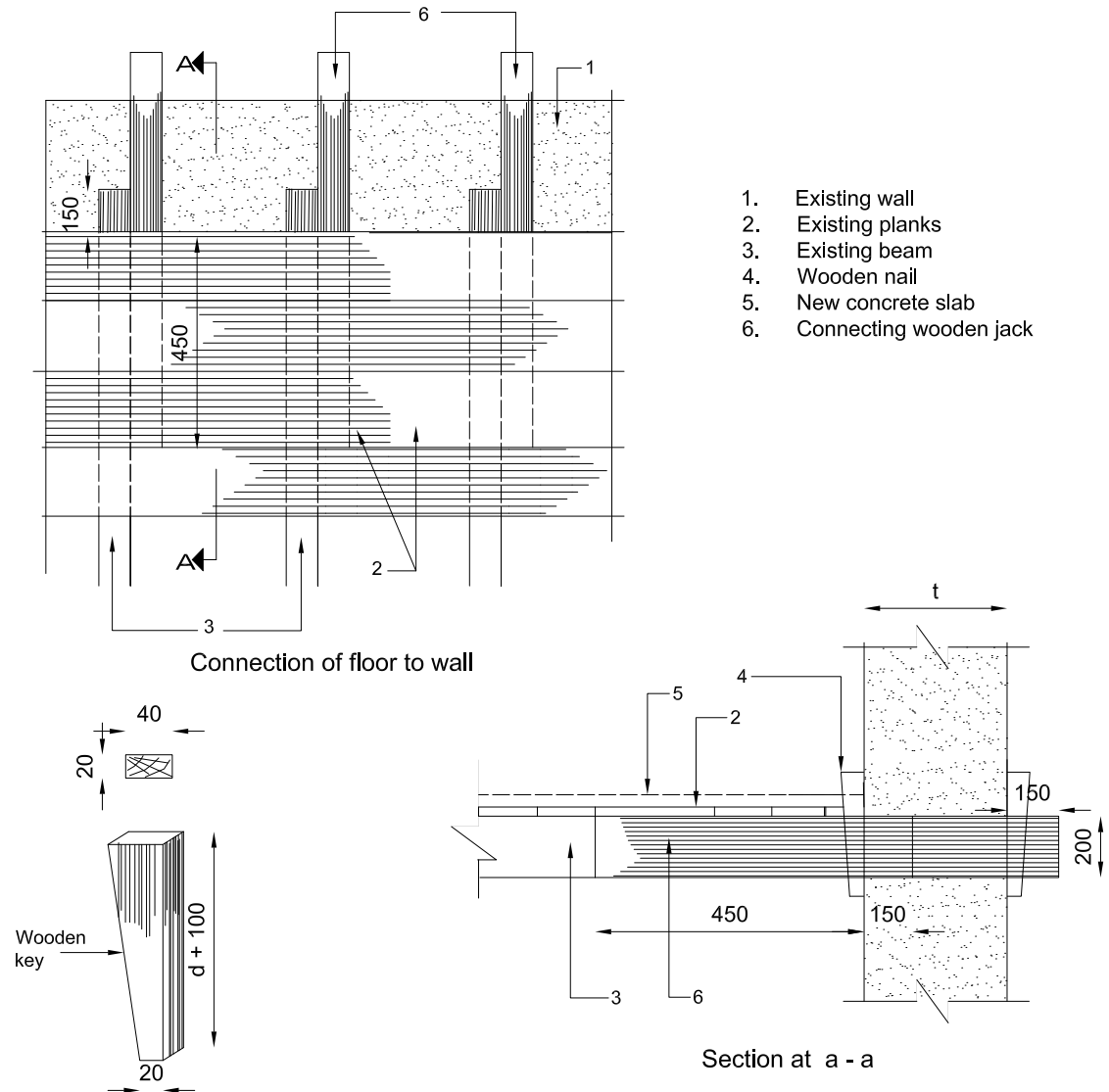

Figure 10.7: Lateral Restrainers

11 Miscellaneous

11.1 Damp-Proof Courses

Damp rising from the ground up into the superstructure not only damages the mud, but also accelerates the decaying of timber and bamboo elements. Damp rising through the floor makes it unhygienic. The rise of damp to the upper portion of a wall can be checked by inserting a damp-proof layer in the wall at the plinth level. In floors, a small quantity of clay is often used to reduce the rocking effect of stone slabs and to increase stability. The same layer, if continued beneath the entire flooring on the ground floor under the floor finish, makes the floor drier and thus more comfortable to live on. A damp-proof layer shall be placed at the plinth level as shown in Figure 11.1.

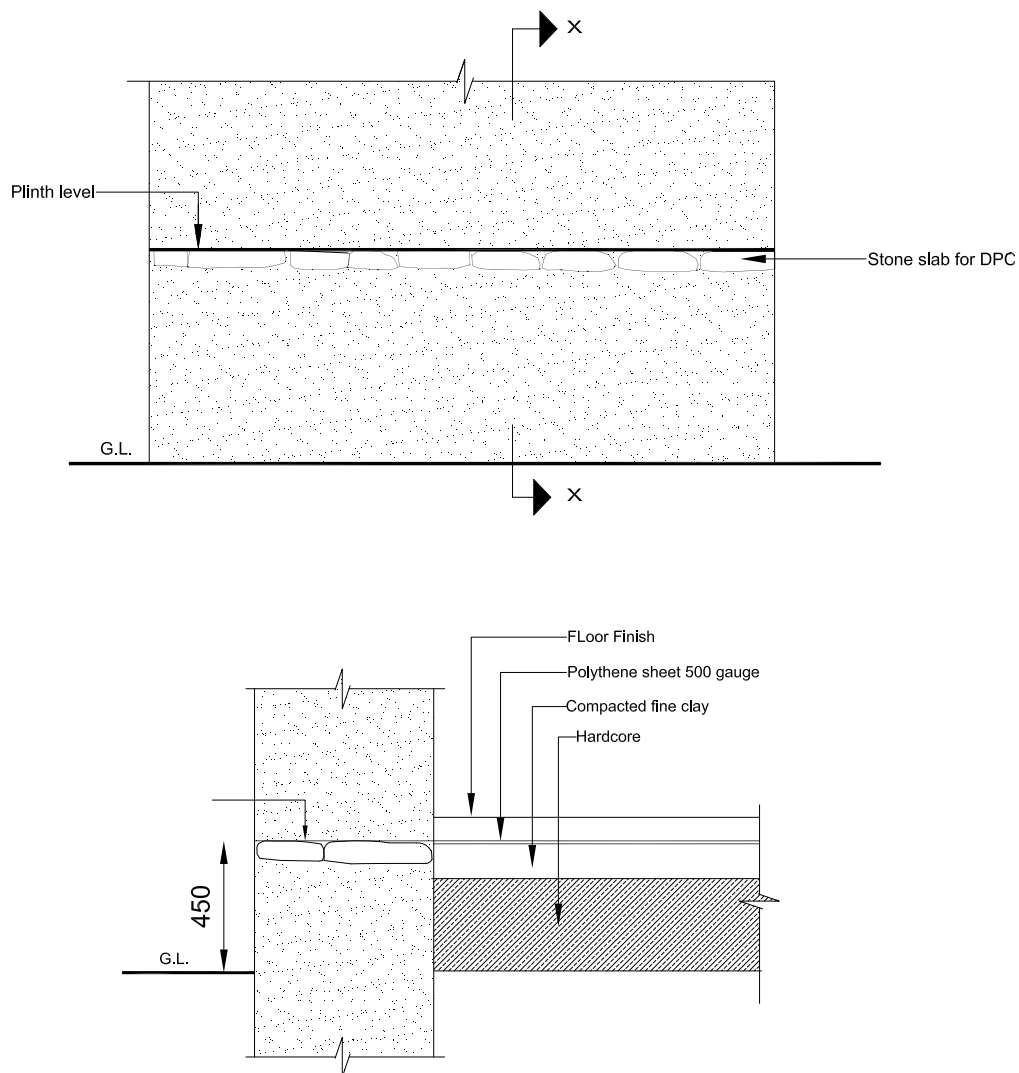

Figure 11.1: Damp-Proof Courses

11.2 Drainage

Site drainage must be provided at the building site. If surface water is not properly drained away, it penetrates the foundation and upsets its stability. A proper drainage system shall be laid all around the building to prevent the penetration of surface water into the foundation. This shall be carried out as illustrated in Figure 11.2.

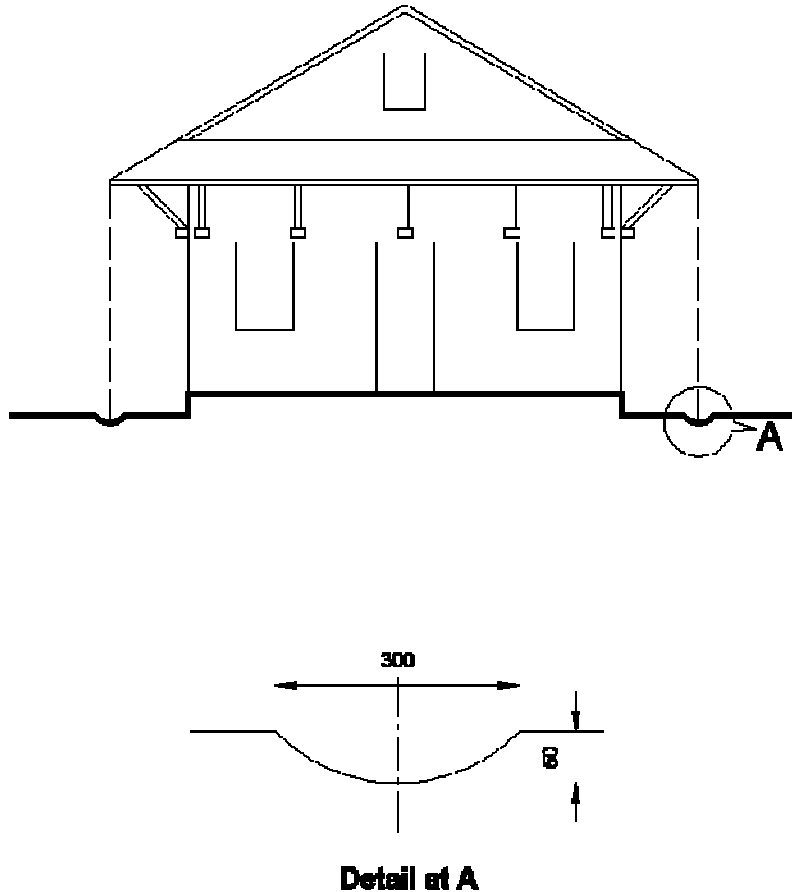

Figure 11.2: Surface Water Drainage around a Building

11.3 Specification and Diameter of Nails

11.3.1 Nails

Common wire nail shall be made of mild steel having a minimum ultimate tensile strength of minimum 500 N/m^2 .

11.3.2 Nails Diameter

Nail diameter shall be between $1/11$ and $1/16$ of the least thick members to be connected.

11.3.3 Nails Length

The length of a nail shall be at least 2.5 times the thickness of the thinner member and it shall penetrate the thicker member by 1.5 times the thickness of the thinner member or $2/3$ of thicker member whichever is greater.

APPENDIX - 1

HARVESTING AND PRESERVING BAMBOO FOR CONSTRUCTION

1 Harvesting and Preservative Treatment

1.1 Harvesting

Bamboo should be three-years old before harvesting. Cutting selectively at a rate determined by ecological conditions, and removing only mature culms three-years old, is the most natural procedure for maintaining a grove in a condition of sustained yield.

Harvesting guidelines prepared by the Dehra Dun Forestry Institute (India) are applicable for Nepal as the climate, the location of Dehra Dun and other conditions are similar to those in Nepal.

Correct harvesting is very essential because proper and systematic harvesting gives a maximum life to cut bamboo for building component use. For some minor house components such as battens, the need for an additional preservative treatment may be prevented if systematic harvesting is carried out.

1.1.1 Harvesting Guidelines

- Do not cut any culm younger than three years, or in the rainy season, or from a flowering grove.
- No cuts shall be made lower than the second node or higher than 30 cm above ground.
- Remove branches, culm tips, and all harvest trash. Debris obstructs growth, encourages disease, and makes later harvesting more difficult.
- Leave leaves for mulch. Their 6 % silica content helps harden later culms.
- A minimum of six mature culms should be left uncut in each clump of tropical species to sustain grove vitality and to insure a steady yield.

1.1.2 Clump Cure

Harvest bamboo at the beginning of the dry season; leave culms standing four to eight weeks in the groves, propped on stakes or rocks, with branches and leaves uncut so as to increase the evaporation surface and diminish insect entry points offered by freshly cut skin. This clump cure not only reduces starch content, which the bamboo beetles seek, but it also greatly decreases the tendency to crack and produces a pleasing uniform colour on the culms. These points can be remembered by the saying "Battle beetles better with clump-cured culms".

1.2 Preservative Treatment

Deterioration by insects, rot, fungi and fire is the most serious drawback to bamboo as a building material. Traditional methods which are widely used to increase the durability of bamboo cost very little and can be carried out without any special equipment or technical knowledge. Harvesting and storing of bamboo in a proper way can increase the preservation of it considerably. The following methods are most appropriate for use in Nepal. Natural preservation as when bamboo is used in a smoky room is also suitable and cheap for some building components.

1.2.1 Water Leaching

The most common treatment for protecting bamboo from Bostrichidae and Lyetidae beetle attack is to leach out the starch, sugars and other water-soluble materials from the freshly-cut stems by submerging them in water. Removal of starch and sugar renders the bamboo unattractive to the beetles.

The bamboo must be completely under water, weighted down if necessary, for periods ranging from three days to three months for freshly-cut bamboo and two weeks longer for partly-dry bamboo. Running water gives better results. Stagnant water sometimes leads to staining of the bamboo.

The susceptibility of bamboo to borer attacks depends on the species, its starch content, age of the culm, felling season, and the physical properties of bamboo (Plank, 1950). But further studies indicate that starch content in bamboo is an important factor influencing the susceptibility to borer (Plank, 1950; 1951). The damage caused by borer has been found to be proportional to the starch content of the bamboo.

1.2.2 White Wash and Other Coatings

A variety of coatings appropriate for Nepal, such as tar, lime wash, tar and lime wash, and tar sprinkled with sand, may be used. However, these are effective only to the extent that they give a continuous coating at cut surfaces, exposed internodes, abrasions and slits.

1.2.3 Brushing, Swabbing, Spraying and Dipping

These surface treatments are adopted for bamboo in storage or before it is given impregnation treatments. Various chemicals are recommended for the protection of bamboo.

Dieldrin 0.05 percent, or Aldrin 0.15 percent, in aqueous emulsions give almost complete protection against *Dinoderus* beetles for over a year. DDT, 7 to 10 % in kerosene oil and BHC, 0.2 percent, are even more effective. Spray application is recommended for stacks of bamboo.

Dipping green or partly dry bamboo for 10 minutes in a 5 % solution of DDT in fuel oil produces a highly-significant degree of control of the *Dinoderus* beetle for about 12 months. Soaking in the same solution for a longer period may result in protection for 24 to 30 months. For exposed bamboo where rainfall is likely, oil-borne insecticides should be prepared.

Except for treating large stocks, no expensive spraying equipment should be required for the prophylactic treatment of bamboo. Hand-operated sprayers should normally be suitable for protection against fungi and borers. A five-minute dip is recommended in a solution containing 2 % borax and 1 % pentachlorophenol in which 1 % is dispersed.

Other methods are available, but these are more complex or costly and need careful processes. They include:

- Steeping, Boucherie process

- Capping hot and cold bath process
- Pressure treatment

It should be noted that the water-leaching method seems to be the most relevant bamboo preservation technique for the Nepalese situation. White wash and other coatings are also suitable as Nepalese people usually paint their houses annually during the Dasain festival.

1.3 Fire-Retarding Treatment

Although not much work has been done on the protection of bamboo against fire, it is possible to treat it with fire-retardant chemicals in the same way as wood. It is worthwhile to treat bamboo with the following fire-resistant cum antiseptic composition:

Ammonium Phosphate	-	3 parts
Boric Acid	-	3 parts
Copper Sulphate	-	1 parts
Zinc Chloride	-	5 parts
Sodium Dichromate	-	3 parts
Water	-	100 parts

A few drops of concentrated hydrochloric acid should be added to the solution to dissolve the precipitated salts.

1.4 Storage

Bamboo should be stacked horizontally on high, raised platforms, at least a foot above ground for the prevention of termite attack. Bamboo should be stored so that all sides can be readily and regularly inspected. Remove or treat attacked culms. At the storage yard, bamboo is air-seasoned under cover for six to twelve weeks to increase strength and avoid cracking. Kiln-seasoning can do the same job in two to three weeks, though at the risk of splitting the outer membrane of several species if the seasoning is too rapid.

To reduce fungal attack, guard bamboo against wetting by rain or contact with soil. Good ventilation and frequent inspection are important. The storage ground should be thoroughly inspected and cleaned before laying out the bamboo. All refuse and useless timber and bamboo should be removed.

Any termite-infested area of ground should be sprayed with a 4 % emulsion of DDT or a 0.2 % emulsion of BHC or other suitable insecticide. Destroy termite colonies by breaking mounds open and pouring in insecticide. The ground should have good drainage facilities.

APPENDIX - 2 FIRE-RETARDANT TREATMENT FOR THATCH

1 General

Obviously, an exposed thatch surface is vulnerable to fire hazards. If this surface is completely sealed with a thin, incombustible layer, it becomes fire-resistant. Since the roof has to be exposed to the atmosphere and subjected to rain, this thin layer has to be water-proof. Thus a layer of NEM plaster seems to be the simplest possible method.

1.1 Materials Required

- Mud
- *Bhusa* (chopped wheat or paddy straw)
- 80/100 grade bitumen
- Kerosene oil
- Cow-dung
- Firewood
- Empty barrels for the melting and mixing of the bitumen

1.2 Method of Preparation

The quantities of different materials given below will be sufficient for the fire-retardant treatment of 100 m² of roof area.

1.2.1 Preparation of Stabilised Mud Mortar

- Collect three cubic metres of mud which contains 40 to 50 % sand and 60 to 50 % of clay.
- Mix 180 kg of chopped wheat or paddy straw with the mud. The wheat straw has to be chopped in 20 mm lengths, whereas rice straw may be up to 50 mm in length. Old straw is preferred to fresh straw. Pour water over it and kneed until the straw and mud becomes an uniform paste.
- Kneed three to four times a day until the straw decomposes. The mix should not be allowed to dry during this process. It takes generally seven days in summer and 14 days in winter to decompose the straw.
- The stabilised mud mortar is then ready.

1.2.2 Preparation of Cut-Back₁ Bitumen (for NEM)

- Collect 85 kg of bitumen and 17 litres of kerosene
- Heat bitumen till it melts
- Pour the melted bitumen into the kerosene and keep stirring till it is thoroughly mixed. (Never pour kerosene into bitumen.)

- The bitumen cut back₁ for NEM is ready.

1.2.3 Preparation of NEM Mortar

- Mix 90 kg of cut back₁ bitumen for NEM with the stabilised mud prepared as stated earlier. Knead thoroughly to a uniform homogeneous mortar.
- The NEM is ready for application.

1.2.4 Preparation of Cut-Back₂ Bitumen for Stabilised Mud Slurry

- Collect 20 kg of bitumen and 2 litres of kerosene
- Heat bitumen until it melts.
- Pour the melted bitumen into the kerosene and keep stirring until it is thoroughly mixed. (Never pour kerosene into bitumen.)
- The cut-back₂ bitumen is ready.

1.2.5 Preparation of Stabilised Mud Slurry₁ for NEM

- Mix 0.1 cubic metres of cow-dung and 0.1 cubic metres of mud. Knead thoroughly by adding water until the mixture becomes a thin paste.
- Add 12 kg of cut-back bitumen to this mixture and mix thoroughly.
- Make a uniform, homogeneous paste by constant stirring.
- The stabilised mud slurry₁ for NEM is now ready to use.

1.2.6 Preparation of Stabilised Mud Slurry₂ for Fire-Retardant Plaster

- Mix 0.1 cubic metres of cow-dung and 0.1 cubic metres of mud. Knead thoroughly by adding water until the mixture becomes a thin paste.
- Add 12 kg of cut-back bitumen to this mixture and mix thoroughly.
- Make a uniform, homogeneous paste by constant stirring.
- Stabilised Mud Slurry₂ for Fire Retardant Plaster is now ready to use.

1.3 Method of Application

1.3.1 Dressing of Roof Surface

- Update all the connections by tying properly and add or replace thatch if necessary.
- When the roof surface has been made uniform, it is ready to receive the fire-retarding plaster.

1.3.2 Application of Stabilised Mud Plaster

- Start plastering with stabilised mud prepared as stated above. The plastering has to start from the top and proceed towards the bottom.
- The thickness of this plaster should be enough to make the surface even and uniform such that it conceals all the bamboo strips and runners on top of the thatch covering.
- Allow this plaster to dry and crack for a day.
- Fill the cracks next day. When the plaster is dry, some more cracks may appear. Repeat the process until the whole wall surface becomes completely free of cracks.

1.3.3 Application of Stabilised Mud Slurry₁

- Make sure that the roof surface is free of cracks. Fill the cracks with NEM if it already exists, and let it dry.
- Apply two coats of stabilised mud slurry₁ over the stabilised mud layer. The application can be either done by hand or with a brush.

1.3.4 Application of NEM plaster

- Start plastering with NEM, prepared as stated above, over the mud slurry₁. The plastering has to be started from the top and continued towards the bottom.
- The average thickness of this plaster should be 12 mm. However, in the higher rain-fall areas, an additional 6 mm thickness of NEM plaster has to be applied.
- Allow this plaster to dry and crack for a day.
- Fill the cracks next day. When the plaster is dry, some more cracks may appear. Repeat the process until the whole wall surface becomes completely free of cracks.

1.3.5 Application of Stabilised Mud Slurry₂

- Make sure that the roof surface is free of cracks. Fill the cracks with NEM if it already exists, and let it dry.
- Apply two coats of stabilised mud slurry₂ to the roof surface, over the NEM plaster. The application can either be done by hand or with a brush.
- The roof is now fire-resistant. The application of the stabilised mud slurry₂ has to be repeated every two to three years for regular maintenance of the NEM plaster.

It is essential to render all the edges and corners of the roof with the treatment for better resistance to fire. The ceiling has to be plastered with a layer of stabilised mud prepared as described above.

APPENDIX - 3 PROTECTION OF MUD WALLS

1 Non-Erodible Mud Plaster (NEM)

Non-erodible mud plaster on wattle and daub, mud and sun-dried brick walls provides protection against erosion caused by splash-water, mainly during the rainy season.

1.1 Materials Required

- Mud (1.5 m³).
- Bhusa (chopped wheat or paddy straw) (90 kg).
- 80/100 grade Bitumen (85 kg).
- Kerosene oil (16 l).
- Cow-dung (0.1 m³).
- Fire wood.
- Empty barrels for melting and mixing bitumen.

1.2 Method of Preparation

The quantities of different materials given hereunder will be sufficient for rendering a water-repellent treatment over 100 m² of wall area.

1.2.1 Preparation of Stabilised Mud Mortar

- Collect 1.4 m³ of mud which contains 40 to 50 % of sand, and 60 to 50 % of clay.
- Mix 90 kg of chopped wheat or paddy straw with the mud. The wheat straw has to be chopped into 20 mm lengths, whereas rice straw may be up to 50 mm in length. Old straw is preferred to fresh straw. Pour on water and kneed until the straw and mud become a uniform paste.
- Knead 3 to 4 times a day until the straw decomposes. The mix should not be allowed to dry during this process. It generally takes 7 days in summer and 14 days in winter to decompose the straw.

1.2.2 Preparation of Bitumen Cut-Back

- The stabilised mud mortar is ready.
- Collect 75 kg of bitumen and 15 litres of kerosene
- Heat bitumen till it melts.
- Pour the melted bitumen into the kerosene and keep stirring until it is thoroughly mixed. (Never pour kerosene into bitumen.)
- The bitumen cut-back is ready.

1.2.3 Preparation of NEM mortar

- Mix 90 kg of bitumen cut-back and stabilised mud prepared as stated earlier. Knead thoroughly to a uniform, homogeneous mortar.
- The NEM is ready for application.

1.2.4 Preparation of Stabilised Mud Slurry

- Mix 0.1 m³ of cow-dung and 0.1 m³ of mud, knead thoroughly by adding water until the mixture becomes a thin paste.
- Add 12 kg of bitumen cut-back to this mixture and mix thoroughly.
- Make it a uniform, homogeneous paste by constant stirring.
- The stabilised slurry is now ready to use.

1.3 Method of Application

1.3.1 Dressing of Wall Surface

- Fill all the put-log holes, cracks.
- Scrape undulations, irregularities and all loose particles.
- When the wall surface has been made uniform, it is ready to receive the NEM plaster.

1.3.2 Application of NEM plaster

- Moisten the wall surfaces by sprinkling water on them.
- Start plastering with NEM prepared as stated above. The plastering has to progress from the top towards the bottom.
- The average thickness of this plaster should be 12 mm. However, in the higher rain fall areas, an additional 6 mm thickness of NEM plaster needs to be applied.
- Allow this plaster to dry and crack for a day.
- Fill cracks with NEM the next day. When the plaster is dry, some more cracks may appear. Repeat the process until the whole wall surface becomes completely free of cracks.

1.3.3 Application of Stabilised Mud Slurries

- Make sure that the wall surface is free of cracks. Fill any cracks with NEM and let it dry.
- Apply two coats of stabilised mud slurry over the NEM-plastered wall surface. The application can be either done by hand or with a brush.
- The wall is now water-proof. The application of Stabilised Mud Slurry has to be repeated every 2 to 3 years for regular maintenance of the NEM plaster.
- Two coats of lime-wash with animal glue may be applied to the wall surface to give a white, clean appearance.

2 Composite Walls

Composite walls with burnt clay bricks on the external skins of external walls, and sun-dried bricks on the inner surfaces and internal walls, are another method of obtaining non-erodible walls. To make such walls, the size of the bricks and the type of binder have to be properly selected. The bricks shall be chosen so that the size of both the sun-dried and burnt clay bricks shall be the same. It shall also be noted that the sun-dried bricks become the main load-bearing elements of the wall. The burnt bricks shall be treated as an external cladding to protect the wall from rain water erosion. However, the burnt bricks shall be properly bonded, as shown in Figure A3.1, to prevent delamination of the wall.

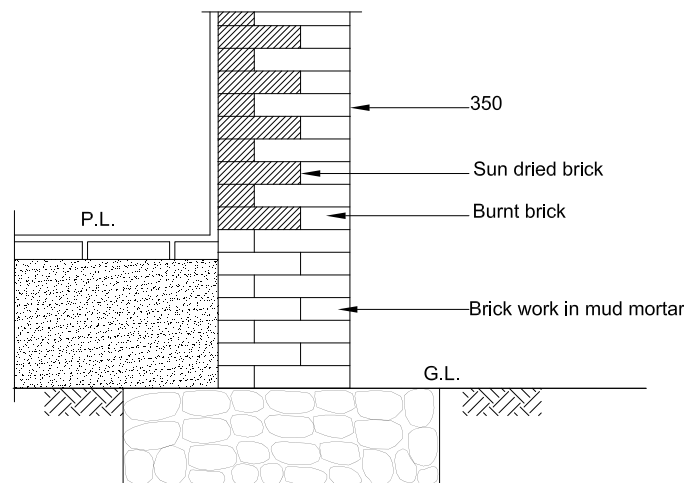

Figure A3.1: Composite Wall

APPENDIX - 4 TERMITE CONTROL IN BUILDINGS

1 General

Termites can be broadly classified into two groups:

- **Dry wood termites:** These termites live inside wood components and are prominent in humid areas. Dry wood termites live in moist timbers and do not come into contact with mud.
- **Subterranean termites:** Mud is the sole agent to provide the necessary moisture for the survival of subterranean termites living in it. They go out of their nests in search of food, mainly timber and bamboo, through tunnels they make. These tunnels are mostly underground.

Since both the termite species cannot live without moisture, a thin, damp-proof membrane continuous on all walls and covering the whole area of the ground floor will help to keep the termites away from a building. Timber and bamboo, if treated for resistance against termite attack, will also help to keep termites away. Some chemicals are available which can be used to create a termite barrier around the building. The type and methods of application of such chemicals are given hereunder.

1.1 Site Clearance

The building site shall be made free from roots of trees and other wooden elements buried in the ground. The roots and such elements shall be uprooted within a radius of 50 m of the building position. If termite mounds are present in the site, they must be destroyed. To destroy such mounds, any one of the following chemicals shall be poured, after physically destroying the mounds. The quantity of these chemicals depends on the mound size. However, 4 litres of the solution per m³ of mound volume will be sufficient. The chemicals are:

- 0.25 % Aldrin
- 0.50 % Heptachlor
- 1 % Chlordane

1.2 Chemical Barriers

A chemical barrier can be created around the building to check the termite moving into the building. Such a barrier shall be created as outlined hereunder.

- The base and the sides of the foundation pit shall be treated to a depth of 300 mm with one of the following solutions at the rate of 5 litres per square metre.
 - Aldrin Emulsifiable Concentrate - 0.5 %
 - Heptachlor Emulsifiable Concentrate - 0.5 %
 - Chlordane Emulsifiable Concentrate - 1 %

- The materials for backfilling the foundation trench shall be treated with one of the solutions. The treatment shall be carried out to a depth of 300 mm at a rate of 7.5 litres per square metre of the vertical surfaces of both the internal and external walls.
- The backfilling of the soil beneath the flooring sub-base has to be treated with any one of the solutions at the rate of 5 litres per square metre of the flooring area for stopping the vertical movement of the termites.

1.3 Precautions

- The chemicals shall be handled with care as all of them are toxic to men and animals. Adequate precautions shall be taken to avoid contamination of food. Empty containers shall be disposed of properly, and any surplus shall be stored in labelled and airtight containers out of reach of children.
- Proper drainage and an apron shall be provided around the building to check the excessive entry of moisture into the foundation.

APPENDIX – 5 SEASONING OF TIMBER

1. Preliminary Treatment And Storage

1.1. The process of drying starts as soon as the tree is cut. Control over drying is, therefore, to be exercised immediately. It is desirable to protect the timber from the early green stage against rapid drying, caused by exposure to sun and hot winds.

1.2. Prevention of Drying of Logs

Seasoning of timber in the form of logs is not possible in practice. If the logs cannot immediately be cut into planks and scantlings, their drying should be restrained by storing under water which is popularly (but erroneously) known as water seasoning. During water storage, the logs should be completely submerged under water. If the water is stagnant as in the case of artificial log-ponds, it should be changed, say once a fortnight, to remove the fermenting material. The bark should be removed before the logs are stored under water. Logs may also be stored in sea water for comparatively shorter periods, but such storage exposes them to the risk of attack by marine borers. In case it is not possible to store logs under water they should be stored on land over raised foundations of masonry or durable or preservative treated timber under shade. In species liable to excessive surface cracking and end splitting, the bark may be left on during storage to retard rapid drying. The practice, however, increases the hazard of insect attack in some cases and should be adopted only where experience indicates that losses through cracking and splitting outweigh those through insect attack. Before stacking, suitable end coating and prophylactic preservative treatment should be given. Logs can also be stored on land under water sprays after debarking. For this, they shall be stacked on a raised cement-concrete platform under continuous or frequently intermittent water sprays. The platform shall be suitably prepared so as to enable collection of the water drained off from the logs into a reservoir which shall be fitted with necessary pipes, centrifugal pump and spray nozzles for lifting the water, its re-spraying and recirculation. Suitable preservatives or insecticides may, if required, be added to the water or it shall be replaced with fresh water at suitable intervals of time.

1.3. Thick sections of all timbers, and specially refractory timbers, are subject to end splitting. This can be prevented or minimized by coating the ends of logs and thick sections of all timbers with some kind of moisture-proof composition up to a distance of 80 mm from the ends. Costly half-wrought for specialized wood products, for which special selection of timber is usually made, should also always be end coated, Some of the effective compositions are mentioned below:

- a. Thick coal tar,
- b. Rosin and lamp black (10:1),
- c. Hardened gloss oil,
- d. Paraffin wax,
- e. Anti-splitting-cum-preservative compound of following composition:

H.S.P. bitumen	Mex R 115/15	37.5
L.S.P. bitumen	Mex R IO/20	12.5
Creosote-fuel oil	(50:50)	5.0

Soap-stone	30.0
Cinder (boiler ash)	<u>15.0</u>
	100.0

f. Bituminous solution in organic solvents,

g. Bituminous solutions in kerosene with boiler ash, having following composition:

H.S.P.bitumen	500 g
Kerosene	250 ml
Boiler ash	100 g

SI No. (a), (b), (d) and (e) are melted and applied hot.

SI No. (c), (f) and (g) are brush coated.

SI No. (f) Can also be sprayed.

1.4. Timber Yard

The timber yard should be maintained under hygienic conditions. It should preferably be level, have a direct approach to the main road and be away from residential areas. The land should be on a high level with proper drainage. It should be well-fenced to prevent cattle from straying inside (so as to avoid dung which is a source of serious infection). The layout of the yard should be such as to enable free movement of transport from one part to another. If the yard is big enough, trolley lines should be provided for easy movement of timber. The storage area for timber should be kept free of weeds and debris that restrict air movement along the ground surface, harbour fungi and insects, and create a fire hazard when dry. It should be surfaced with gravel in order to restrict weed growth. To protect the stack of timber from direct sun, there should be some big shady trees in the yard.

1.5. Methods of Stacking

1.5.1. Logs (Awaiting Conversion)

These should be stacked on foundation in closed stacks in one or more layers. The ends of logs should be coated with an ant splitting composition. Top protection against direct sun should be provided by shade of trees or a covering of rejected odd-sized planks (wherever available) so arranged as to provide sufficient overhang at both log ends.

1.5.2. Railway Sleepers

In order to provide to a certain extent, the drying conditions suitable for the species of timber either the 'one and nine' (see Fig. 1) or the 'close crib' (see Fig. 2) method of stacking should be adopted. The 'one and nine' method is suitable for moderately heavy timbers, particularly coniferous sleepers in hot climate and for heavy timbers, in moist climate. All coniferous sleepers in northern India and non- coniferous sleepers in moist zones of southern India, West Bengal and Assam should be stacked by this method. The 'close crib' method gives slower seasoning as it reduces the air circulation. This is recommended for stacking sleepers of refractory timbers in hot and dry localities, such as sal in Terai. The 'open crib' method (see Fig. 3) is a modification of 'close crib' method allowing more air circulation. The effect of drying of timber by this method is almost the same as in the 'one and nine' method. This is not a common method of stacking sleepers. Stacks, each containing about 100 sleepers are recommended. The center-to-center distance of crossers shall not exceed 1.5 m. These methods of stacking can also be used for short lengths of thick scantlings.

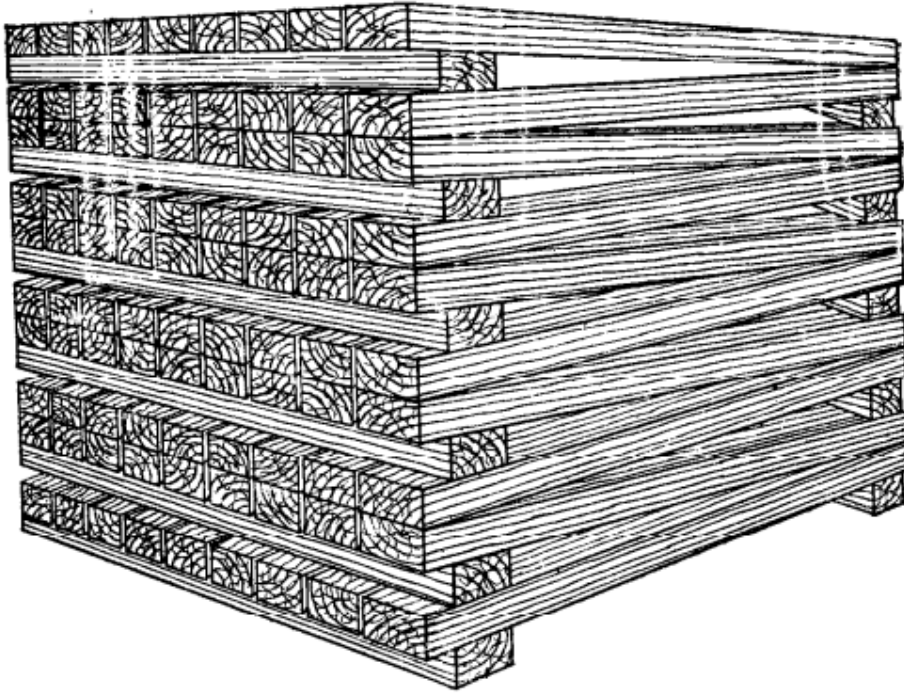

FIG. 1 ONE-AND-NINE STACKING

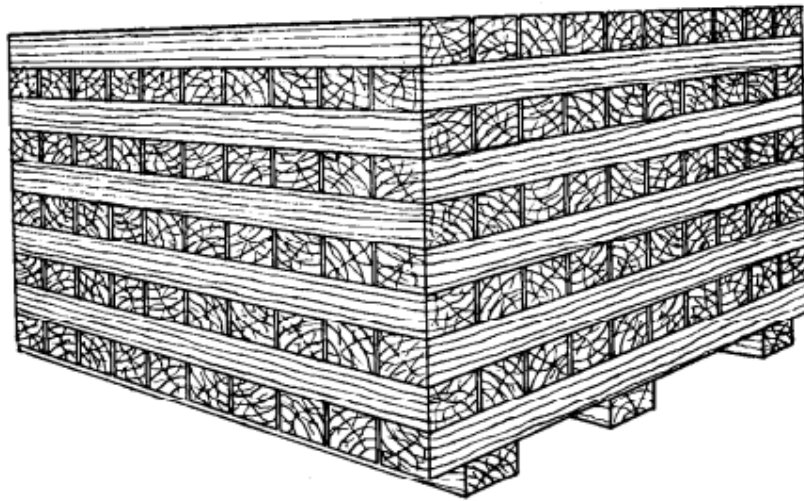

FIG. 2 CLOSE CRIB STACKING

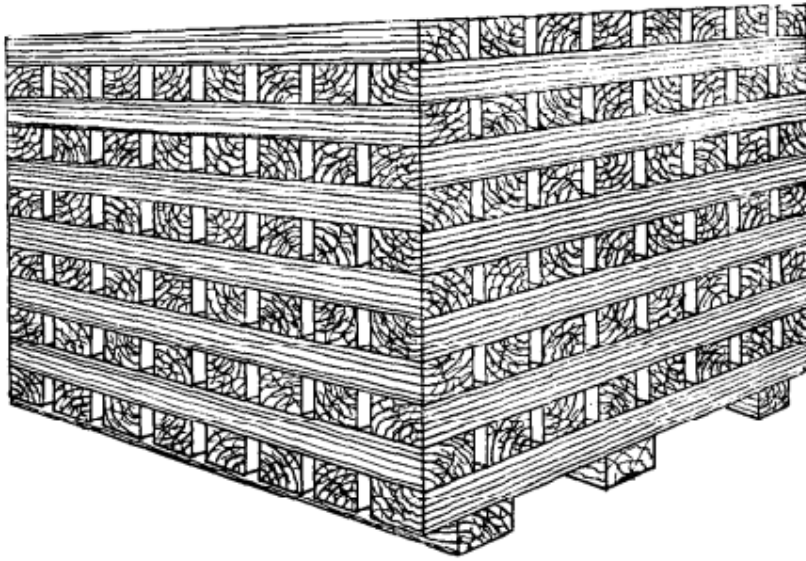

FIG. 3 OPEN CRIB STACKING

1.5.3. Poles

After debarking, poles should be stacked either in closed heaps or with crossers. In case of stacking in closed heaps, there should be alternate layers of butt ends and top ends at one end of the stack so as to keep the two ends of the stack level (see Fig. 4). In the case of stacking with crossers some of the poles themselves could be used as crossers. The centre-to- centre distance of crossers shall not exceed 3 m.

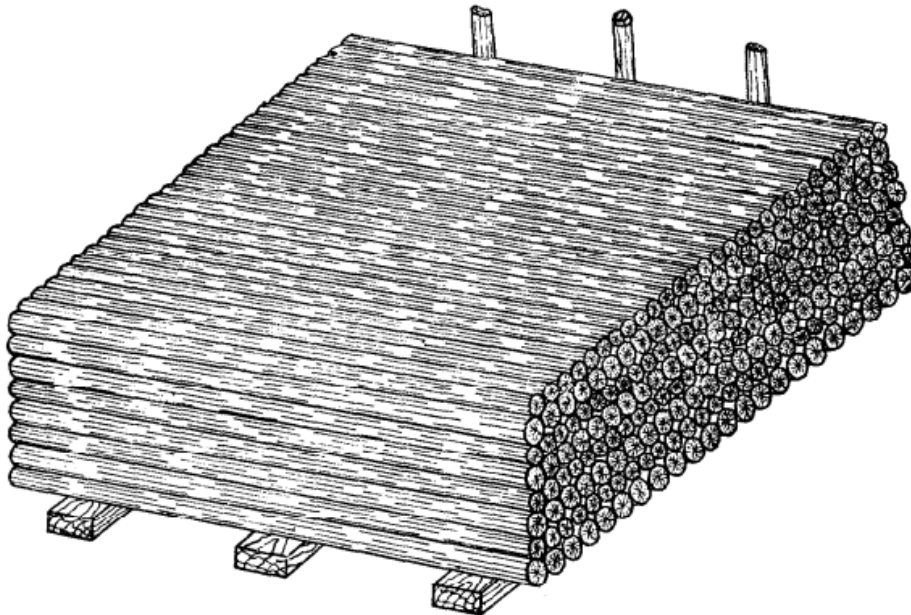

FIG. 4 STACK OF POLES

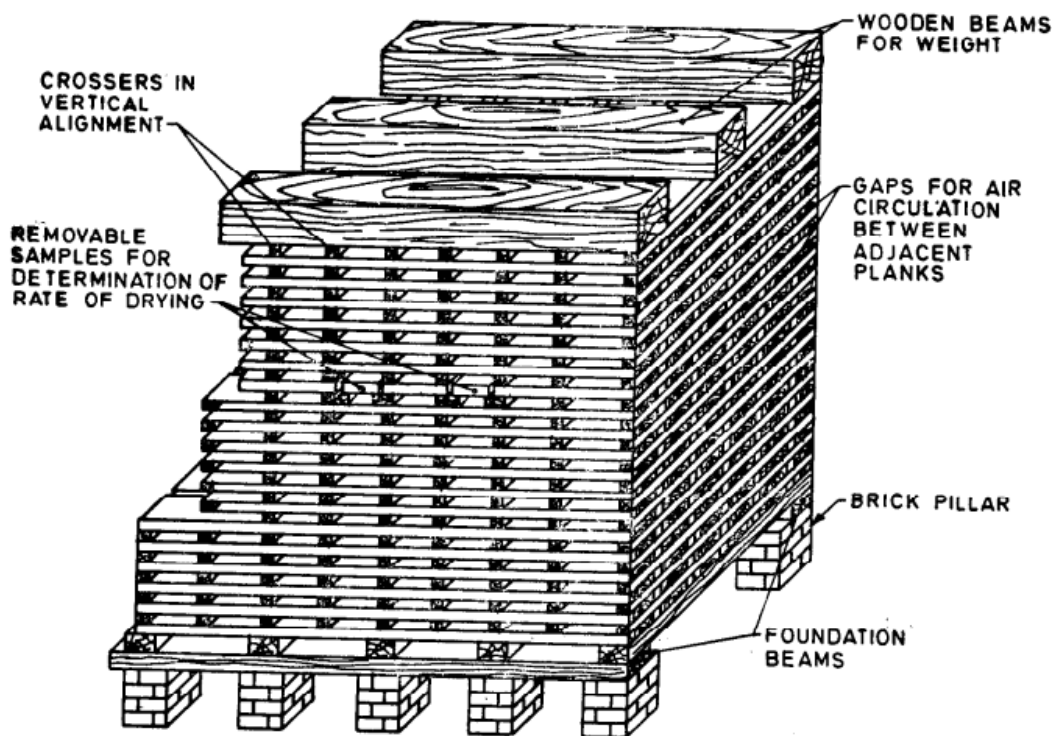

FIG. 6 HORIZONTAL STACKING OF PLANKS FOR AIR SEASONING

1.5.4. Horizontal Stacking of Sawn Timber (Other than Railway Sleepers)

1.5.4.1. Foundations

Vertical pillars of treated timber or brickwork or concrete are integral parts of the foundation. They should be 3000 mm^2 in cross-section and 300 to 450 mm in height and should be spaced about 1.2 m apart (center-to-center) along the length and width of a stacking unit. The length of the unit should depend upon the length of material to be stacked. Adjoining stacking units should be spaced at least 750 mm apart for ease of stacking and proper air circulation on all the sides of the stacks. The galleys between adjoining rows of stacks should be aligned with the wind direction in localities where more or less a perennial wind direction obtains.

1.5.4.2. Long beams of suitable cross-sections, say 100 mm x 100 mm and above, should be placed above the foundation pillars to serve as a framework for the stacking of timber. These foundation beams should be prepared from strong timbers which should be treated with a suitable wood preservative.

1.5.4.3. Scantling and squares (baulks)

These should be stacked with crossers 50 mm x 40 mm in cross section kept 2.5 m apart. The stacks should be raised to convenient heights, say up to 3 m. The ends shall be covered with a moisture-proof composition. It is desirable that the width of individual stacks does not exceed 2.0 m.

1.5.4.4. Planks

The stacking should be done on level foundations of skids. Crossers should be of uniform thickness and cross-section, say 40 mm x 25 mm for stacking planks up to 50 mm in thickness. The distance between the successive crossers in the layer

should be about 600 mm for 25 mm thick planks. For thicker planks, the spacing may be increased to 750 mm. In case of very thin planks or species prone to warping, the spacing may be reduced to 450 mm. The crossers should be in vertical alignment in a stack. In the case of mixed lengths, the longest planks should be at the bottom and the shortest ones on the top. The stacking should be done under a shed to protect the timber against sun and rain. Heavy wooden beams, steel rails or concrete slabs should be placed at the top to minimize warping. It is desirable from the point of view of uniformity of drying that the width of the stacks should not exceed 1.5 m but if it does, an open space called flue or chimney about 250 mm wide should be left in the middle of the width from top to bottom to permit good air circulation in the center of the stack. Gaps about 25 mm should also be left between adjoining planks in all the layers to allow free vertical movement of air.

1.5.4.5. Top weighting should be uniformly distributed over the stack and should act through a top layer of crossers and not directly over the top layer of planks. A minimum weighting of 380 kg/m² is recommended for control of warp and cup.

2. Seasoning Methods

2.1. Seasoning methods should be classified as follows:

- a) Air seasoning; and
- b) Kiln seasoning.

2.2. Air Seasoning

2.2.1. Sawn material for air seasoning should be stacked under shade, preferably in a shed. Three-recommended standard designs of sheds are described in 2.2.1.1 to 2.2.1.3.

2.2.1.1. Shed Type 1

It consists of a roof with walls on all four sides, with gates at the two ends for the movement of timber. Adjustable shutter should be provided towards the top and bottom of the walls to control ventilation (see Fig. 7A). This type of shed is suitable for seasoning and storage of refractory timber in hot and dry climate such as sal (*Shorea robusta*) and laurel (*Terminalia alata*).

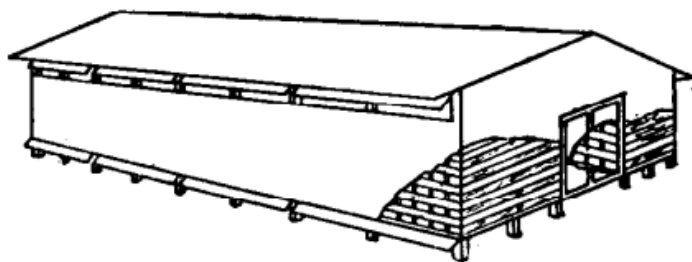

7A SHED TYPE 1

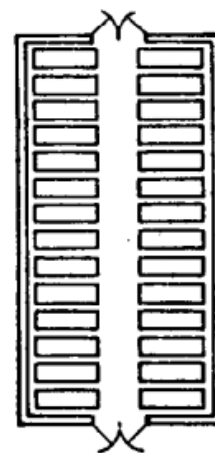

PLAN

2.2.1.2. Shed Type 2

It consists of a roof with walls on three sides, north side being open (see Fig. 7B). This is suitable for moderately refractory timbers like teak (*Tectonagrandis*) and rosewood (*Dalbergialatifolia*), except in very moist climate.

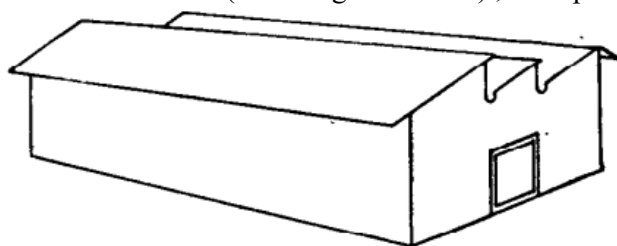

7B SHED TYPE 2

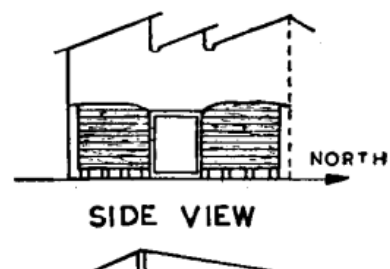

2.2.1.3. Shed Type 3

It consists of a roof supported on pillars, all sides being open (see Fig. 7C). This is suitable for refractory and moderately refractory timbers in very moist climate, and non-refractory timber in a dry climate.

7B SHED TYPE 2

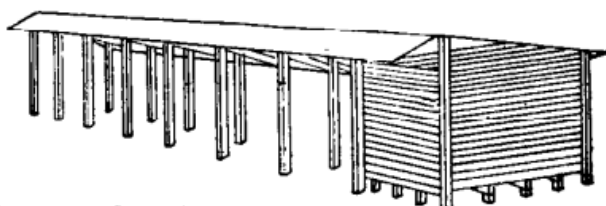

7C SHED TYPE 3

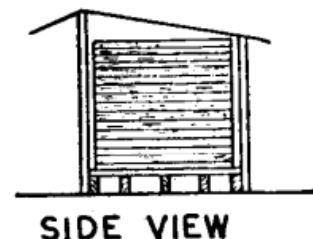

2.2.2. The width of air seasoning sheds shall preferably be limited so to accommodate not more than two parallel rows of stacks plus the width of the intervening passage for movement of timber. The walls of the shed can be made of brick, durable or treated timber planks or asbestos cement sheets or treated bamboo reinforced lime and mud plaster walls. Timber can also be used for the columns. For the roof CGI sheets with or without a covering of treated wood shingles or corrugated asbestos cement sheets or compressed preservative and fire-retardant treated thatch boards can be used. CGI sheets, when used without covering, should be at least 2.4 m to 3.0 m above the top of the stacks to minimize heat radiation to the timber from the roof, or else, a ceiling should be installed below the sheet roofing to cut off radiation. A pucca floor should be provided. At the time of doing earthwork anti-termite measures shall be adopted. The roof should have sufficient overhang on all sides to prevent direct spray of rain water. Proper drainage should be provided for the surrounding ground.

2.2.3. For protecting timber from insect attack and decay during storage and seasoning a suitable prophylactic treatment should be given.

2.2.4. Air seasoning is usually a slow process. The actual period required will vary with the size and species of timber and the seasonal variations of climate. Ordinarily, timber should not be considered as fully air seasoned in less than six months. Planks of broad leaved species (hardwoods) 25 mm in thickness may take three to four months to season in a moderate climate. Scantling as used for door and window frames may take from 6 months to a year to attain reasonable degree of seasoning.

APPENDIX - 6 REFERENCE MATERIALS

1. "A Manual of Earthquake-Resistant Non-Engineered Construction", Indian Society of Earthquake Technology, University of Roorkee, India.
2. "IS 13827 : 1993 (Reaffirmed 2003) Edition 1.2 (2002-04) Improving Earthquake Resistance Of Earthen Buildings — Guidelines"
3. "Protection of Educational Buildings Against Earthquakes", Professor AS Arya.
4. "School Construction Manual", HMG/UNCHS(Habitat), Kathmandu, Nepal.
5. "Live Better with Mud and Thatch", CBRI, Roorkee, India.
6. "Earthquake-Resistant Measures for Small Buildings", EAARRP, MHPP, HMG Nepal.
7. "Detailer's Manual for Small Buildings in Seismic Areas", Teddy Boen, Indonesia.
8. "Seismic Strength of Adobe Masonry", J Vargas, J Bairola, and M Blondet, Earthquake Engineering Laboratory, Catholic University of Peru, Lima, and PK Meheta, Civil Engineering Laboratory, University of California, Berkeley, USA.
9. "Termite Control in Buildings", Building Research Note 50, CBRI, Roorkee.

APPENDIX - 7 GLOSSARY

The following terms used in this document are explained below:

ABRASION means surface-wearing of a material due to friction with another material/materials in contact.

ADOBE means sun-dried clay brick work with mud mortar.

ADVISORY means suggestion (of better construction techniques, materials, etc) as opposed mandatory rules whose enforcement is assured by law. Non-observance of "Advisory" rules will be harmful to the owner.

ANCHORED means fixed with devices like nails, bolts, hooks, etc., for ensuring better load transfer.

ASYMMETRIC means the plan or section or view is not symmetrical.

BAMBOO GROVES means a group/groups of bamboo trees at a particular place where they are growing naturally.

BAND means reinforced concrete or reinforced brick or wooden runner provided horizontally in the walls to tie them together and to impart horizontal bending strength in them.

BASE PAD means a member of a relatively stronger material provided at the base-end of a beam/post so as to transfer the load on to a wider area so that damage of the wall/support due to local point-load effect is avoided.

BEARING means a supporting base material provided at the end of beams/joists to reduce the concentrated load effect.

SEISMIC-RESISTANT CONSTRUCTION means construction in which earthquake-resistant structural and non-structural elements are incorporated.

BOSTRICHIDAE means a kind of beetle (insect) that attacks the bamboo.

BOX EFFECT means the effect by which an arrangement of individual elements, when connected together in a sound manner, can create a stronger structure than the sum of the individual element strengths. Various binding elements such as horizontal and vertical reinforcement, diagonal bracing and lateral restrainers, bands, etc. can bring about this effect.

BRIDGING MATERIALS means materials used to span between two or more joists to form a floor and stabilise the individual joists.

CGI SHEETS means corrugated galvanised iron sheets, mostly used as a roofing material.

MUD WALL means a wall constructed with kneaded lumps of mud and compacted.

CULM means a single unit of a bamboo tree.

DALAN means a one-side-open enclosure on the ground floor of a rural building, usually on the

front face of the building.

DAMP-PROOF COURSE means a relatively dense layer of water-proofing material provided below the plinth level in a wall or side of a building to prevent upwards migration of damp.

DECIDUOUS TREES mean trees that lose their leaves annually, usually in autumn.

DIAGONAL BRACING means the bracing of a wall or other members fixed diagonally at appropriate positions.

DINODERUS BEETLE means a kind of beetle that attacks bamboo.

EMBEDDED means placed firmly such that the bond is ensured.

FIRE-RETARDANT means material or a process that decelerates the spread of fire.

FLEXIBLE STRUCTURES means structures that do not have sufficient rigidity to resist deflection.

FUNGAL ATTACK means a kind of infection (by fungi).

GABLE BAND means a continuous band provided on the gable wall to hold it together during an earthquake.

GEOLOGICAL FAULT LINES mean geological discontinuity lines on the ground surface that may cause earthquakes.

HAZARDOUS means an area or situation that is susceptible to damage or destruction.

HORIZONTAL BAND means a continuous member that may be of wood or bamboo or reinforced cement concrete. Provided at plinths, lintels and roof levels as required.

INSECTICIDE means a chemical that kills insects.

JHINGATI means traditional local burnt-clay tiles for roofing. Usually of small size.

LAND SUBSIDENCE means relative upheaval or lowering of land with respect to the adjacent land.

LATERAL RESTRAINERS means elements provided to restrain the walls in a horizontal direction (usually wooden keys) and to keep walls in position during horizontal loading.

LATERALLY RESTRAINED means has lateral resistance to falling.

LIQUEFACTION means a ground condition where the soil completely loses its load-bearing capacity and flows like liquid and any foundation sinks into the ground. It occurs mostly in saturated sand layers.

LYETIDAE means a kind of beetle that attacks bamboo.

MANDATORY means rules and regulations that are governed by a legal mandate and shall be

observed.

MARSHY means low-lying wet land.

METH (CAPITAL) means a member of relatively larger surface area provided at supporting surfaces to distribute the load uniformly to the supporting posts.

MICRO CONCRETE ROOFING (MCR) means roofing tiles having projected binding wires embedded into the tiles for anchoring.

MUD SLURRY means mud mixed with water so as to make it a semi-liquid.

NATURAL HAZARDS means hazards occurring naturally. For example, landslides, floods, earthquakes, etc.

PLINTH means a floor raised from the natural ground level in a building to improve hygienic conditions in the building.

PLUMB LINE means the vertical line shown by a plumb-bob (a weight hung on a length of string)

PRESERVATIVE TREATMENT means the treatment of timber or bamboo to preserve it from insects and/or decay.

PROPHYLACTIC means tending to prevent a disease or attack from harmful insects.

RUPTURE LINES means the lines of failure of an object.

SAPWOOD means a soft layer of wood between the bark and the inside hard core.

SEISMIC SAFETY means safety against earthquake damage.

SILL means the bottom level of an opening in a wall.

SOFT-STOREY EFFECT means the poor structural behaviour of a storey in a building in which a particular lower storey has lesser rigidity than the storeys above it.

STRUTS means cross-ties provided between two main elements to maintain their integrity and rigidity.

SUPERSTRUCTURE means the structure above the plinth level such as walls, roofs, etc.

SWABBING means the process of cleaning bamboo or timber with cotton cloths.

SWAMP means soft, wet land in which foundations should be erected only after proper treatment.

TERMITES means small insects, found chiefly in tropical areas that are very destructive to timber (popularly called white ants).

TERMITE INFESTED AREA means area where the termite are living, growing and cause damage to timber or bamboo where they are living.

UN-STIFFENED means members that are not strengthened or has the less stiffness.

UNBALANCED OPENINGS means the opening not being in proper places and storeys that may cause unbalanced stiffness or soft storey effect.

UNSUPPORTED WALL LENGTH means the wall length without the buttresses or cross walls provided to reduce damage.

VERNACULAR BUILDINGS means traditional buildings constructed in a locality.

VERTICAL REINFORCEMENT means the vertical ductile element provided to increase the ductility of structure.

VULNERABILITY means vulnerability is the ratio of expected loss to the maximum possible loss.

VULNERABLE means a structure is said to be vulnerable if the damage is expected at a given hazard.

WATER REPELLANT means materials that repel or show no affinity to water.

WATER LOGGED means area saturated with water possessing lack of drainage.

WATER LEACHING means process of treating timber or bamboo in water to raise its resistance to termites and beetles by leaching out starches, sugar etc.