

My English

1

Teacher's Guide

Government of Nepal
Ministry of Education, Science and Technology
Curriculum Development Centre
Sanothimi, Nepal

Publisher

Ministry of Education, Science and Technology

Curriculum Development Centre

Sanothimi, Bhaktapur

© Publisher

All rights reserved, no part of this publication may be reproduced, stored in a retrieval system, or transmitted in any form or by any means, electronic, mechanical, recording or otherwise, without the written permission of the publisher.

First Edition: 2020

Computer Layout : Khados Sunuwar

Printed by:

Preface

Curriculum, textbook and teacher's guide are the minimum tools and resources for a teacher. These resources make teaching learning activities smooth in the classroom. This teacher's guide has been developed to assist the teachers teaching English in Grade one . It contains the detail description of how the English teacher is expected to carry out English language learning activities in the classroom with reference to the lessons in the textbook.

The activities suggested in this book are the samples for teachers to teach the contents from the workbook. Teachers can use additional activities and create their own activities to suit the objectives of the lesson.

Learning becomes effective if students are engaged in language learning tasks through various means and interactive techniques such as discovery, discussion, question answer, problem solving, brainstorming and so on. It is expected that this book will help teachers encourage students to develop the habit of learning by doing, confidence in learning English, and creativity in class.

This teacher's guide has been prepared by a team of English language practitioners that include Dr. Ganga Ram Gautam, Mr. Shankar Adhikari, Mr. Nim Prakash Singh Rathaur, Mr. Nabin Kumar Khadka and Mr. Ramesh Dhakal. The Director General of the Curriculum Development Centre Mr. Keshav Prasad Dahal provided guidance and feedback in the process of preparing this book. The subject committee chair Prof. Dr. Balmukunda Bhandari and other members also contributed in bringing this book in this form. Thus, Curriculum Development Centre expresses its sincere gratitude to all who contributed to this endeavor.

CDC always welcomes constructive suggestions.

2020

**Curriculum Development Centre
Sanothimi, Bhaktapur**

Table of Contents

About the Teacher's Guide	1-8
Me and My Family (Lesson 1-14)	8-42
Alphabet (Lesson 15-72)	43-166
Me and My Family	167-173
Lesson 73: Head and Shoulders	167
Lesson 74: I See with My Eyes	170
My Daily Life	174-195
Lesson 75: Brush Your Teeth	176
Lesson 76: I Can Jump	180
Lesson 77: I'm Happy	184
Lesson 78: It's Seven O'clock	188
Lesson 79: Seven Days	191
Our School	196-215
Lesson 80: Come Here	198
Lesson 81: May I ...?	201
Lesson 82: I'm Pawan	205
Lesson 83: Things in the Classroom	208
Lesson 84: Let's Play	211
Our Environment	216-229
Lesson 85: On the Table	218
Lesson 86: The Rainbow	222
Lesson 87: Red Rose	224
Lesson 88: This is a Bag	227
My Belongings	230-240
Lesson 89: In the Bag	232
Lesson 90: Under the Table	235
Lesson 91: Things at Home	238
Lesson 92: Where Are My Shocks?	241

Our Culture	243-251
Lesson 93: Dashain	245
Lesson 94: Birthday	249
Communication, Technology and Market	252-262
Lesson 95: Ramu is a Farmer	254
Lesson 96: Rice and Curry	257
Lesson 97: Vehicles	260
Fruits and Vegetables	263-274
Lesson 98: Fruits	265
Lesson 99: A/An	268
Lesson 100: Vegetables	272
Hobbies and Interests	275-282
Lesson 101: I Like Fruits	277
Lesson 102: I Don't Like Leaves	281
Birds and Animals	283-304
Lesson 103: The Tiger	286
Lesson 104: The Cock	289
Lesson 105: Birds in the Tree	292
Lesson 106: On/In/Under	295
Lesson 107: Big and Small	298
Lesson 108: My Pet	301

About the Teacher's Guide

The student workbook 'My English Book 1' has been developed following the integrated curriculum including the themes and language skills envisioned for the students who have just started learning English in a foreign language. The book comprises a set of activities that will serve as the foundation for the English language learning in a gradual manner. This teacher's guide has been prepared to help teachers teach My English Book 1 effectively and it has been structured in such a way that teachers find comprehensive guidelines in it to deal with all the activities of the workbook. This book includes lesson outlines with step-by-step direction to teach each and every activity. Each activity focuses on developing specific skills and knowledge and the book offers a variety of activities to facilitate the tasks of the workbook and sustain the interest and motivation of the students. It is, however, true that teacher is the key actor to deliver the curricular contents in the classroom. The activities suggested here in this book are only the examples. A teacher can adopt or adapt these activities as per the students' needs and interest.

In a diverse classroom context and varied students' needs, the teacher might need to use additional resources and activities to support learning. Here in this book, a list of activities are introduced in the introductory part of before lesson-wise task-wise activity section begins. This book offers lesson plans with lesson focus, list of the learning outcomes of the lessons, materials needed to deliver the lesson and the detail activities to be carried out in the classroom and suggested homework.

The teacher's guide follows the same thematic principles in the presentation of the lessons. There are 11 themes (one theme 'Me and my Family' comes at two times) in the workbook and 108 lessons. This teacher's guide has also been divided into 11 sections and each section starts with the introduction of the theme. The introduction to the theme connects to the related lessons in other subjects so that it is helpful in integrated teaching. If you are a grade teacher, teach the lessons of the same theme across the subjects and try to connect the previous lesson (of another subject) to the present one so that students see connection among the different subjects. The best way to do this is to teach lessons from the same themes in all the four subjects. However, there are some subject-specific themes like 'Alphabet' in English and you can teach the lessons in those themes separately.

You will see, at the beginning of each theme, a table that tells you the number of the lessons, skill-wise learning outcomes, and focused soft skills and so on. This helps you to take into account the broader objectives of the theme. Each lesson of all the themes has been divided into different sections under headings like; look and read, listen and sing, read and write

etc. You will have to review each lesson plan to find out what skill each activity focuses on. There are some icons in the workbook/textbook to inform you what skills (listening, speaking, reading, and writing) are to be focused in the specific lessons.

At the end of each theme, there is 'Assess Yourself' section followed by suggested tasks for assessing the students' learning. Some themes may contain lesser number of tasks in comparison with the number of objectives. You can decide whether more tasks are necessary or not. If you think you need more tasks, you could design the tasks yourself. All the tasks are given along with the materials given in the student book.

Understanding the Structure of the Workbook/Textbook

The textbook/workbook has been prepared for the beginners. English may be totally new language for students. The lessons in the beginning of the book might look easier for you but it may not be the case for students. Children should not be taught to write the alphabets in pre-primary classes instantly. They need some time to get prepared for learning. The activities are designed to address this. There's a purpose behind each section of the lessons; e.g. colouring is to develop the skill of holding and taking control over the pencil. So make sure that you engage your students in the suggested task in the way that develops the knowledge/skill behind it.

The textbook has been structured into three broader sections: pre-decodable, decodable and post-decodable phase. Each phase has been described below:

1. Foundation phase (Lesson 1-14)

Students need to develop basic foundational skills to be successful in school when they first enter grade one. They need exposure to the pre-reading activities such as concept of prints, develop oral vocabularies, listening comprehension and pre-writing activities such as colouring, tracing and writing of strokes. Therefore, before you teach reading and writing, use the first 14 lessons to involve the students in different pre-listening, pre-reading and pre-writing activities.

In this phase students may not be able to understand and use English. Therefore, you can use their mother tongue along with English while conducting classroom activities. The instructions should also be given in students' mother tongue so that they can understand what you want to communicate to them. Students cannot read the words and expressions in English here here but they can imitate the words and may be able to understand their meanings.

2. Decodable phase (Lesson 15-72)

After foundation phase, the course will start with phonics for 58 lessons as decodable phase. This phase includes teaching of phonological awareness activities; introduction

to the alphabets/letters; words and decodable vocabulary activities; listening and reading comprehension and writing activities based on the phonic scheme as copying and dictation. This phase is further divided into early-decodable and decodable phase.

Early decodable phase: During the early decodable phase, students build a strong foundation in phonics. It is designed to help students build their knowledge of letters and sounds, so that they can start decoding texts when they move to the latter stage. Students, in this phase, read letters, syllables and words. They may not be able to read decodable texts at this point as they are still not exposed to sufficient number of words. They read the words as pictures. They still cannot decode the letters in words. The major activities in this phase include:

- Listening and saying words in the picture
- Learning new words and their meaning (orally)
- Identifying letters using pictures
- Producing and practising sounds
- Reading letters
- Writing letters

During decodable phase, the goal is to enable students to read decodable text as they see the text. Students in this phase have significant practice in reading the decodable texts along with the new letters and words. Significant number of letters, syllables and words are already introduced in early phase of decoding. The decodable texts will increase in complexity as students continue to develop their knowledge of the language. Students also learn vocabulary and practise reading comprehension through the decodable texts they read each class. Major activities in this phase include:

- Listening and saying words in the picture
- Learning new words and their meaning
- Identifying letters using pictures
- Producing and practising sounds
- Blending and segmenting sounds
- Reading letters
- Practising rhyming words/rhymes
- Blending letters/sounds to read words
- Reading decodable words
- Writing letters, words and phrases

3. Post-decodable phase (Lesson 73-108)

After introducing all the language symbols (alphabets), the course moves into post-decodable phase. This phase focuses on developing fluency, vocabulary and comprehension. The aim of this phase is to enable students to read the level appropriate texts accurately at normal speed with expression. Students, in this phase, learn vocabulary and practise comprehension through the connected texts. The texts in this phase are simple but the complexity increases gradually. They also start writing at this phase. Major activities of this phase are:

- Listening and speaking
- Reading and learning new words and concepts
- Reading for fluency (Reading texts speed)
- Reading for comprehension (reading and doing comprehension tasks) orally as well as in writing
- Writing (words and sentences)

Principles of learning facilitation

English classroom should have a happy atmosphere where children hear and speak language in a natural manner through a variety of activities. All four skills will come together but students will start learning things orally and aurally before reading and writing. There will be many opportunities for pupils to talk to each other in pairs or groups or in front of the whole class. Praise your students for their efforts and achievement so that it will help each child to make progress. From the beginning, creativity and pupil's independent use of the language should be encouraged.

The teaching of English should be guided by the following principles:

- Learners should get ample exposure to the target language.
- Learners should use the target language as much as possible.
- Learning environment should be anxiety free.
- Learners must be encouraged to take risk while learning the language.
- Errors should be taken as natural outcomes in the learning process.
- Learners should develop a positive attitude towards the target language.
- Student talking time (STT) must be maximized in the classroom.
- Learners should take responsibility of their own learning.
- Different learners learn in different ways and the teachers need to deliver their lesson accordingly.

Basic considerations for conducting classroom activities

Study of curriculum, learners' workbook/textbook: The teachers need to study the

curriculum and workbook/textbook to see their interrelationship and deliver the lesson as per the intention of the curriculum.

Involving multiple senses of the learners: The learners should be provided with an opportunity to use multiple senses in learning. They should be given an opportunity to touch, feel and play. The activities should ensure active participation of learners and enhance their creativity. There should be the use of visuals such as; pictures, drawing, images, and videos in all lessons. The learners need to be involved in simple craft activities.

Integration of soft skills: Learning activities should enhance various soft skills such as intrapersonal skills like self-management, self-discipline, responsibility, courage, etc. and interpersonal skills such as communication, co-operation and sympathy. Such activities contribute in acquiring different multi-literacy skills and the skills required to be a good citizen.

Communicative tasks: An attempt has been made to make activities more learner-friendly, more communicative, more inductive and more participatory. For the better learning of the second language, the learners should be provided with an ample opportunity to use language for meaningful communication in real-life context. Therefore, involving them in communicative tasks is very important. Communicative activities like; information gap-activities, role play, simulation, dramatization, language games, picture describing, group work and pair work should be used as far as possible.

Providing a correct language model: A teacher is students' a role model. The language used by the teacher is a model for students. Therefore, teachers should use the correct language in the classroom. Teachers should keep themselves in the position of the learners, and try to discover new features of the target language.

Ensuring self-pacing: All the students do not have the same learning speed and the same ability to grasp the concept. Therefore, students should be given chance to learn in their own pace. Likewise, fast learners can be requested to help their friends who learn slowly.

Addressing diversity and promoting inclusiveness: Diversity among the learners is a common feature of almost all classrooms in Nepal. While making instructional plans, socio-linguistic background, disabilities and multiple intelligences of the students should be considered, and inclusiveness should be ensured thereby. The following strategies can be helpful for addressing diversity in English language classroom:

- Bringing variety in the content, tasks and activities
- Maintaining correct pacing of learning in activities
- Putting learner's interest at the centre of lesson planning

- Using collaborative activities like pair work and group work
- Allowing learners' choice in tasks or materials they use
- Allowing different individual responses, based on learners' own experience, opinions or imagination
- Using mandatory plus optional strategy in assigning tasks and activities

Assessment as and for learning: Evaluation should be considered as an integral part of teaching- learning activities. It should be a medium for the improvement of learning. It should not be used merely for assessing what has been learnt and what not.

Provision for remedial teaching: The basis for the evaluation of a student should be the outcomes that one should achieve after the delivery of a lesson or unit. Learners who seem to be performing low should be given an opportunity to improve in their own pace with the help of the remedial learning activities. Remedial teaching can take the form of re-teaching, modification in instructions, change in the activities and so on.

Priority to grade teaching: The provision of grade teaching should be implemented by the schools as far as possible. If it is not possible, joint plans for learning should be made by a team of teachers who teach in the particular grade.

Linking learning with the prior knowledge of students: The learning facilitation process should begin with some pictures and examples to connect the learner's experiences or events. The prior knowledge of the learners should be used in the learning process. Discussion should be carried out to elicit information from the students so that new learning can be built upon their previous knowledge.

Opportunity for expression: Students should be provided with ample opportunities to think, discuss, express and compare the content with their experiences.

Enhancing cooperative learning: Students should be provided with opportunities to learn from one another, share their own experiences and help among themselves in learning.

Ensuring minimum learning: Before moving to the next stage of learning, the learning of basic skills by the students should be ensured. Learners must have the competencies of fundamental concepts and skills before going to the next subject matter or the skill.

Considering the interest of the child: The interest of the learners should be considered while selecting and conducting learning activities. The activities which arouse learners' interest should be used.

Assessing and reviewing students' progress: After teaching a specific lessons or a unit, the

progress made by the students should be assessed. Assessment process should be made as informal as possible to make it non-threatening for the learners and learning activities need to be reviewed after the assessment.

Bringing variety in activities: Variety should be brought in the learning process and activities. The activities in which students can learn through experience should be chosen. All the students do not learn in the same way. Some learn better by listening, some by watching, and some by moving and so on. Therefore, there should be variety in classroom activities.

Using outdoor activities: Since children love the things of the nature like birds, animals, trees and flowers, they should be taken out of the classroom for learning. Their learning should be linked with the real life environment around them.

Providing opportunities for making presentations: The students should be provided with the opportunity to present their tasks, materials, their learning experiences and creative arts in the class.

Using dictionary: Dictionary is a very important resource for learning language, especially in vocabulary learning. Various aspects of the words can be taught by using the dictionary. Therefore, the teachers should consult the target language dictionary and encourage students to do the same.

Using fun activities: Learning English at lower grades should be fun. For this, the learners should be involved in various interesting activities such as chants, rhymes, action songs, dramatization, role play and language games.

Using I do, we do and you do sequence

Providing a model/Presentation (I do): Since, the learners at this level, are at the beginning phase of language learning, they cannot use language on their own, and every feature of second language becomes new for them. Therefore, it will be helpful for the teacher to provide a model before the students are asked to contribute. For example, teachers should provide a model pronunciation of words before the students pronounce them. The teacher can give examples, demonstrate something, provide models, provide guidelines to the students and set background for the next stage. For example, if the topic is picture describing, the teacher can show the picture and provide a sample description with the key vocabulary.

Meaningful practice (We do): The role of practice is crucial in learning a foreign language. Knowing about a language and using a language are different things. Learners may know about a language but they may not be able to use it for communication in the absence of practice. Therefore, students should be provided with an opportunity to

practise language both inside and outside the classroom. While practising language, the teacher should assist the students in doing tasks. The teacher invites the learners in the task and involves herself/himself in the process. Since the students cannot do activities and tasks independently at this stage, teacher's support is necessary. Students may work in pairs, in groups or individually. For example, students describe the picture working in pairs with the help of the teacher.

Production (You do): After the students get ample opportunity to practise language with the support of the teacher, they should be involved in free communicative activities. At this stage, students do the task freely without teacher's support. This stage is also called free practice. Here the focus is on fluency, not on accuracy, i.e. correctness of language. The activities of this stage are more communicative and very close to real life. For example, students describe the given picture freely without teacher's support.

Example of I do, we do and you do: Drilling of words

Presentation (I do)

- Ask the children to look at the objects (book, ball, bat) and listen to the pronunciation of words.
- Show objects one by one and pronounce their names slowly.
- Repeat it at least three times.

Practice (We do)

- Ask the children to repeat after you as you pronounce the words. Repeat it at least three times.
- If the children cannot pronounce the words properly, help them to pronounce.
- Now practise pronouncing with the children at the same time. Repeat it at least three times.

Production (You do)

- Now ask the children to pronounce the words themselves freely.
- Do not correct the students even if they cannot pronounce well.

Theme: Me and My Family

Children learn from his family. They come to school with the knowledge about their family members, friends, and things at home. This knowledge is the foundation for further learning at school. The children will learn to identify family relations, greet people, introduce themselves and other, trace lines and pictures, recite rhymes throughout the theme.

Number of Lessons: 14

Soft skills

- Communication
- Team work
- Respect for diversity
- Critical thinking
- Active listening
- Sense of belonging
- Taking care of self

Language function

- Greeting and leave taking
- Introducing
- Talking about home and family

Skill-wise objectives:

Listening

1. Imitate, identify and discriminate sounds.
2. Blend individual sounds in simple one-syllable words. (e.g. /s/ /i/ /t/ →sit)
3. Respond to the audio or the teacher non-verbally and verbally.
4. Perform different kinds of listening tasks (e.g. drawing, matching, etc.).

Speaking

1. Imitate and produce sounds and words.
2. Pronounce grade appropriate words correctly.
3. Give basic personal information about themselves (e.g. name, address, family, nationality) using short words and phrases.
4. Ask and answer short, simple questions.
5. Sing or recite a song/chant by listening to the teacher or an audio.

Reading

1. Put sounds together to read words and sentences.
2. Recognize and read familiar words accompanied by visuals.
3. Perform rhymes and chants with appropriate rhyme and rhythm.
4. Understand the meaning of grade appropriate words.
5. Read words, simple sentences and short paragraphs correctly.

Writing

1. Hold pencil correctly to gain control to draw lines, curves, circles, etc.
2. Develop hand-eye coordination through drawing lines and patterns.
3. Trace the letters and write them.
4. Demonstrate good handwriting skills.

Lesson 1

In this lesson, there are four topics to cover:

1. Listen and say (Listening and speaking)
2. Point (Pre-reading: recognition)
3. Colour (Pre-writing skill: hand eye coordination and pencil control)
4. Listen and sing the chant.

Objectives:

- greet orally (good morning/afternoon).
- identify similar and different pictures.
- hold pencil correctly and gain control over it.
- sing and enjoy the chant.

Materials:

crayons, song chart, sample outline picture of an apple

Before you teach:

1. Study the workbook thoroughly.
2. Have the materials ready.
3. Listen to the chant on the internet to learn the tune.

(<https://www.youtube.com/watch?v=F4tHL8reNCs>)

1. Listen and say

15 minutes

Activity 1

- Greet students by saying ‘Good morning/afternoon class’.
- Say ‘Good morning/afternoon class’ a couple of times and look at the response you get.
- If you do not get the response ‘Good morning/afternoon Sir/Miss/Teacher’, ask them to respond to you. Ask them to repeat for a couple of times.

Activity 2

- Ask some students to go out. Ask the class to say 'good morning/afternoon' when the students come in.
- When they come in, ask them to practice ‘good morning/



afternoon (student's name) and the student who comes in to say 'good morning/afternoon class'.

- Do it with as many students as possible.

Activity 3

- Go to different students randomly in class and say 'good morning/afternoon (student's name) and try to get the response 'good morning/afternoon sir/miss/teacher'.
- Do it with as many students as possible.

Activity 4

- Ask students to move around the class and say 'good morning/afternoon (student's name)' and get the same response from their friends.
- Do these practice activities until all students in class say the expression 'good morning' correctly.

Activity 5

- Call two students to the front of the class and ask them to greet each other in English by calling their names.
- First you demonstrate it with a student and then ask students to do the same.

Activity 6

- Ask the students to look at the picture and see the things there.
- Then ask simple questions. Like:
 - a. What do you see in the picture?
 - b. Who is the father doing?
 - c. What is the mother doing?
 - d. What is the daughter doing?
 - e. Which animal do you see?
 - f. What is it doing?, etc.
- The students may not understand the question in the English language. Thus the teacher can also use the mother tongue or Nepali. Similarly, they may answer in Nepali or in their mother tongue. In such situation, the answer into English.

2. Point (to the same pictures in each row) 15 minutes

This is the topic for students to see and identify the pictures. Ask students: What do you see in the picture? What are they doing? (Tell them that they can use their own language)

Point (to the same pictures in each row).



(similarities and differences). Move around the class and monitor.

Activity 1

- **Ask:** How many pictures can you see? Which pictures are similar? Why? (Use Nepali in asking questions if they don't understand in English)
- Ask them to work in pairs and talk about the pictures

3. Colour

15 minutes

This is a colouring activity. This aims to develop hand-eye coordination skill and the skill to gain control over pencil.

Activity

- Use the picture given in the workbook.
- Provide crayons.
- Demonstrate a coloured picture of an apple.
- Ask the students to use the similar colour.
- Demonstrate them the correct way of holding the crayon. And make sure that they are all holding the crayon correctly.
- Ask the m to see the border of the picture.
- Tell them that they should colour inside the border only.
- Demonstrates them how should they colour it.
- Teach them to colour either from left to right and top to bottom.
- Asks them to colour gently without living any white mark.
- Once they colour, ask them to show to each other.

Colour:

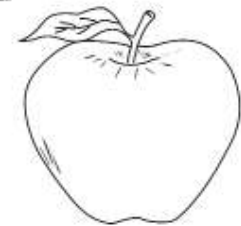

4. Listen and Sing

15 minutes

Songs and rhymes are very useful to learn a foreign language. Students like songs. Learn how to sing the song or rhyme before you go class. Practise the rhyme yourself several times so that you can sing it properly in class. In this lesson, the rhyme is Johny, Johny Yes Papa. Go to the following link, listen how this is sung and practice it before class.

<https://www.youtube.com/watch?v=F4tHL8reNCs>

If you can save it on your mobile or you can go online during the class, you can also show this to the students during the class.

Activity 1

- Tell students that you are going to sing a song for them.
- Ask them to listen to you.
- Sing the rhyme while the students listen to you.
- After you sing it a couple of times, ask them to repeat after you.
- Do it several time with actions.
- You need to continue until everyone gets the rhyme.

Activity 2

- Tell students that you are playing the role of Papa and students are playing the role of Johny.
- Now practise it several times.
- Swap the roles and practise it again.

Activity 3

- Ask students to work in pairs. One of them will be Papa and another one will be Johny. Ask them to practice is several times.
- Randomly pick some pairs and ask them to show it for the whole class.

Homework

Learn the song by heart with the help of your brother/sister.

Listen and sing.

Johnny Johnny I
Yes, Papa.
Eating sugar?
No, Papa.
Telling a lie?
No, Papa.
Open your mouth.
Ha ha ha!



Lesson 2

In this lesson, there are four topics to cover:

1. Listen and practise (Listening and speaking)
2. Point (Pre-reading: recognition)
3. Colour (Pre-writing skill: hand eye coordination and pencil control)
4. Colour the way (Pre-writing skill: hand eye coordination and pencil control)

Objectives:

- greet orally (good morning/afternoon).
- identify similar and different pictures.
- hold pencil correctly and gain control over it.

Materials:

crayons, sample outline picture of a tree

Before you teach:

1. Study the workbook thoroughly.
2. Have the materials ready.

1. Listen and practise

20 minutes

Activity 1

- Ask the students to look at the picture and see the things there.
- Ask simple questions such as:
 - a. Who are there in the picture?
 - b. Where are they?
 - c. What are they doing? Etc.
- The students may not understand the question in the English language. Thus the teacher can also use the mother tongue or Nepali. Similarly, they may answer in Nepali or in their mother tongue. In such situation, translate the answer into English.



Activity 2

- Tell students that you are going to sing a song for them.
 - Ask them to listen to you.
- Good morning, teacher.
Good morning, friends.
Good morning to you all.

- Sing the rhyme while the students listen to you.
- After you sing it a couple of times, ask them to repeat after you.
- Do it several times with actions.
- You need to continue until everyone gets the rhyme.

Activity 3

- Call students one by one to the front of the class and ask them to greet the teacher and their friends.
- First you demonstrate it, and then ask students to do the same.

2. Point (to the same picture)

15 minutes

Point (to the same pictures in each row).



Follow the procedure suggested in 'Lesson 1, point to the same picture'.

3. Colour

10 minutes

Colour.

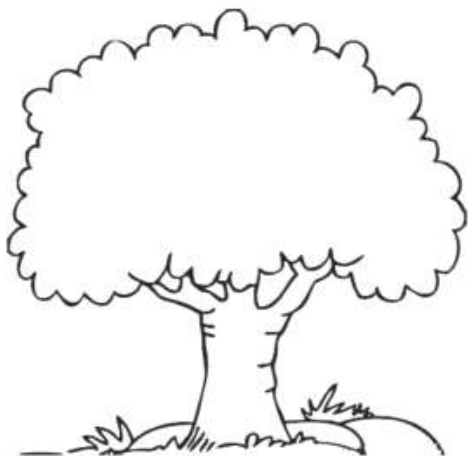

Follow the procedure suggested in 'Lesson 1, colour'.

4. Colour the way

15 minutes

This is a colouring activity. This aims to develop hand-eye coordination skill and the skill to gain control over pencil. This activity also develops the soft skills like critical thinking and decision making.

Activity 1

- Ask simple questions to the students about the picture.
 - a. What do you see?
 - b. How can the girl reach to the rabbit?
 - c. Which way should she follow?

Once they find the right way, ask the students to colour the way to get to the rabbit.

Support them as needed.

Homework

Learn the song by heart with the help of your brother/sister.

Colour (the way).



Lesson 3

In this lesson, there are four topics to cover:

1. Listen and say (Listening and speaking)
2. Point (Pre-reading: recognition)
3. Colour (Pre-writing skill: hand eye coordination and pencil control)
4. Colour the way (Pre-writing skill: hand eye coordination and pencil control)

Objectives:

- greet orally (good morning/afternoon).
- identify similar and different pictures.
- hold pencil correctly and gain control over it.

Materials:

crayons, sample outline picture of a parrot

Before you teach:

1. Study the workbook thoroughly.
2. Have the materials ready.

1. Listen and say

20 minutes

Activity 1

- Ask the students to look at the picture and see the things there.
- Then ask simple questions. Like:
 - a. Who are there in the picture?
 - b. What are they doing?
- The students may not understand the questions in the English language. Thus the teacher can also use the mother tongue or Nepali. Similarly, they may answer in Nepali or in their mother tongue. In such situation, the teacher will translate the answer into English.



Activity 2

- Tell students to follow you and read the expressions of greetings given in the picture one by one.
- Conduct whole class drill and then small group drill.
- Tell them the situation in which each of the expressions is used.

Hi - informal, with friends and family
 Hello - formal, usually with the people you don't know
 Good morning - more formal, used before 12 in the morning
 Good afternoon - more formal, used after 12
 Good night - to say goodbye when someone is leaving for home or going to bed

- Call some of the students in front of the class.
- Provide them the situation in which they choose the right expressions discussed above and use them.

2. Point (to the same picture) 15 minutes

Point (to the same pictures in each row).



Follow the procedure suggested in 'Lesson 1, point to the same picture.'

3. Colour 10 minutes

Colour:

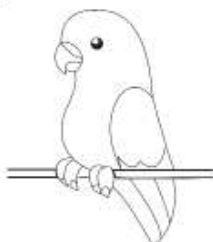

Follow the procedure suggested in 'Lesson 1, colour.'

4. Colour the way 15 minutes

Colour (the way).



Follow the procedure suggested in lesson 2, Colour the way.

Homework

Learn the expressions discussed in the second activity under 'Listen and say' with the help of your seniors or any member in the family.

Lesson 4

In this lesson, there are four topics to cover:

1. Listen and act (Listening and speaking)
2. Point (Pre-reading: recognition)
3. Colour (Pre-writing skill: hand eye coordination and pencil control)
4. Listen and sing

Objectives:

- greet and take leave orally (good morning/afternoon).
- identify similar and different pictures.
- hold pencil correctly and gain control over it.
- sing and enjoy the chant.

Materials:

crayons, animal puppets, sample outline picture of a house

Before you teach:

1. Study the workbook thoroughly.
2. Have the materials ready.

1. Listen and act

20 minutes

Activity 1

- Ask the students to look at the picture and see the things there.
- Then ask simple questions. Like:
 - a. What do you see in the picture?
 - b. What are they doing?
- The students may not understand the questions in the English language. Thus the teacher can also use the mother tongue or Nepali. Similarly, they may answer in Nepali or in their mother tongue. In such situations, translate the answers in English.

Listen and act.



Bye bye.
Goodbye.
Bye bye.
Goodbye.
I can clap my hands.
Bye bye.
Good bye.

Activity 2

- Tell students that you are going to sing a song for them.
- Ask them to listen to you.
- Sing the rhyme while the students listen to you. Use the puppets of the animals

in the picture and act like them while singing.

- After you sing it a couple of times, ask them to repeat after you.
- Do it several time with actions.
- You need to continue until everyone gets the rhyme.
- Then, provide the puppets to the students and ask them to sing in the same way as you did.

2. Point (to the Same Picture)

15 minutes

Point (to the same pictures in each row).



Follow the procedure suggested in 'Lesson 1, point to the same picture.'

3. Colour

10 minutes

Colour.



Follow the procedure suggested in 'Lesson 1, colour'.

4. Listen and sing

15 minutes

Listen and sing.

Hello, Maya!
How are you?
Fine, thanks.
What about you?



Follow the procedure suggested in 'Lesson 1, Listen and sing, Activity 1.'

Homework

Learn the rhyme with the help of your seniors or a member of your family.

Lesson 5

In this lesson, there are four topics to cover:

1. Look and say (Listening and speaking)
2. Point (Pre-reading: recognition)
3. Colour (Pre-writing skill: hand eye coordination and pencil control)
4. Colour the way (Pre-writing skill: hand eye coordination and pencil control)

Objectives:

- take leave orally (good morning/afternoon).
- identify similar and different pictures.
- hold pencil correctly and gain control over it.

Materials:

crayons, sample outline of the picture as in the task 'Colour'.

Before you teach:

1. Study the workbook thoroughly.
2. Have the materials ready.

1. Look and say

20 minutes

Activity 1

- Ask the students to look at the picture.
- Then ask simple questions. Like:
 - a. Who are there in the picture?
 - b. What are they doing? Etc.
- The students may not understand the questions in the English language. Thus the teacher can also use the mother tongue or Nepali. Similarly, they may answer in Nepali or in their mother tongue. In such situation, translate the answer in English.

Look and say.



Activity 2

- Act as if you have finished the class and you are going out.
- Tell them 'Bye' and ask them to say 'Bye bye.'
- Repeat it a couple of times.
- Ask some students to go out of the class saying 'Bye' and rest of others will say

'Bye bye'.

- You need to continue until everyone learns to say 'Bye' and 'Bye bye'.

2. Point (to the Same Picture)

15 minutes

Point (to the same pictures in each row).



Follow the procedure suggested in 'Lesson 1, point to the same picture.'

3. Colour

10 minutes

Colour.



Follow the procedure suggested in lesson 1, colour.

4. Colour the way

15 minutes

Colour (the way).



Follow the procedure suggested in 'Lesson 2, Colour the way.'

Homework

Learn the expressions 'Bye' and 'Bye bye' with the help of your senior.

Lesson 6

In this lesson, there are four topics to cover:

1. Look and say (Listening and speaking)
2. Colour the same picture (Pre-reading: recognition)
3. Trace and colour (Pre-writing skill: hand eye coordination and pencil control)
4. Trace the way (Pre-writing skill: hand eye coordination and pencil control)

Objectives:

- introduce orally (good morning/afternoon).
- identify similar and different pictures.
- hold pencil correctly and gain control over it.

Materials:

crayons, pencils, a sample of dotted outline of a rectangle

Before you teach:

1. Study the workbook thoroughly.
2. Have the materials ready.

1. Look and say

20 minutes

Activity 1

- Ask the students to look at the picture.
- Then ask simple questions. Like:
 - a. Who are there in the picture?
 - b. Where are they?
 - c. What are they doing?
- The students may not understand the questions in the English language. Thus the teacher can also use the mother tongue or Nepali. Similarly, they may answer in Nepali or in their mother tongue. In such situation, translate the answer in English.



Activity 2

- Introduce yourself saying "Hello, everyone. I amyour name..... What's your name?"
- Repeat it for a couple of times.
- Ask each student to say his her name. Help them saying, "My name is"

The student says his/her name.....

- Once all the students tell their names in this way, ask them to say "My name is individually.
- Make sure that each student learns to introduce himself/herself saying "My name is..... ."

2. Colour (the Same Picture)

15 minutes

- Ask: How many pictures can you see? Which pictures are similar? Why? (Use Nepali in asking questions if they don't understand in English)
- After they identify the same picture in each row, ask them to colour using the same colour as in the first picture.

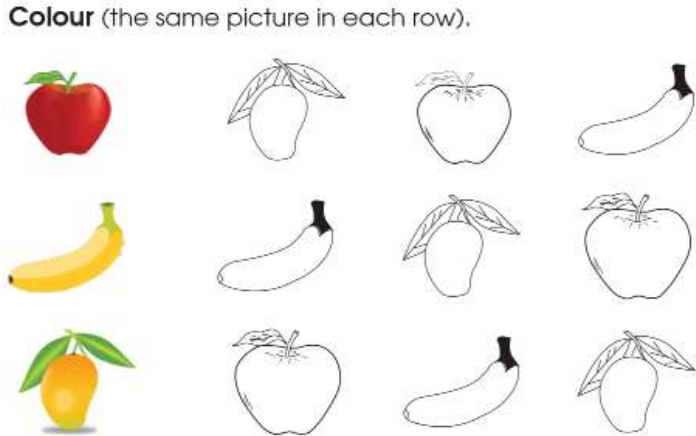

3. Trace and colour

15 minutes

This is a tracing activity. The aim is to develop hand-eye coordination skill and the skill to gain control over pencil.

Trace and colour.

Activity

- Use the picture given in the workbook.
- Provide pencils.
- Demonstrate how they should trace over the dotted line.
- Ask the students to trace in the similar way.
- Demonstrate them the correct way of holding the pencil. And make sure that they are all holding the pencil correctly.
- After they trace over the border, ask them to colour it.
- Tell them that they should colour inside the border only.

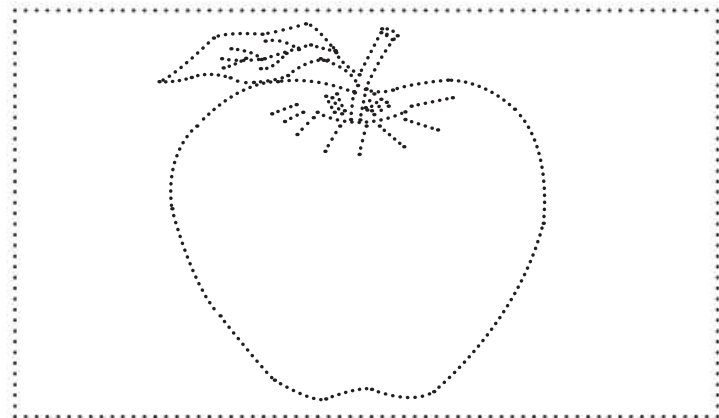

- Demonstrate them how they should colour it.
- Teach them to colour either from left to right and top to bottom.
- Asks them to colour gently without leaving any white mark.
- Once they colour, ask them to show to each other.

4. Trace the way

10 minutes

Follow the procedure suggested in 'Lesson 2, Colour the way.'

Trace (the way).



Homework

Learn to introduce yourself with the help of your senior.

Lesson 7

In this lesson, there are four topics to cover:

1. Listen and act (Listening and speaking)
2. Colour the same picture (Pre-reading: recognition)
3. Trace and colour (Pre-writing skill: hand eye coordination and pencil control)
4. Listen and sing

Objectives:

- introduce orally (good morning/afternoon).
- identify similar and different pictures.
- hold pencil correctly and gain control over it.
- sing and enjoy the chant.

Materials:

crayons, pencils, a sample of dotted outline of a triangle

Before you teach:

1. Study the workbook thoroughly.
2. Have the materials ready.

1. Listen and act

20 minutes

Activity 1

- Ask the students to look at the picture.
- Then ask simple questions. Like:
 - a. Who are there in the picture?
 - b. What are they doing?
- The students may not understand the questions in the English language. Thus, the teacher can also use the mother tongue or Nepali. Similarly, they may answer in Nepali or in their mother tongue. In such situation, translate the answer in English.



Activity 2

- Call 4/5 students in front of the class.
- Introduce yourself saying "I amyour name....."
- Repeat it for a couple of times.
- Ask each student to say his her name. Help them saying, "I amThe

student says his/her name.....

- Once all the students tell their names in this way, ask them to say "I am " individually.
- Now ask each student to introduce himself/herself saying "I am name....."

2. Colour (the same picture)

15 minutes

Colour (the same picture in each row).



- Follow the procedure suggested in lesson 6,

3. Trace and colour

10 minutes

Trace and colour.

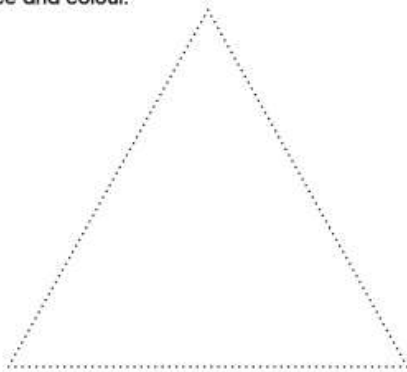

Follow the procedure suggested in 'Lesson 6, Trace and colour'.

4. Listen and sing

15 minutes

Listen and sing.

Two big apples
Under a tree.
One is for you
And one is for me.



Follow the procedure suggested in 'Lesson 1, Listen and sing, Activity 1'.

Homework

Learn the rhyme with the help of your senior.

Lesson 8

In this lesson, there are four topics to cover:

1. Listen and say (Listening and speaking)
2. Colour the same picture (Pre-reading: recognition)
3. Trace and colour (Pre-writing skill: hand eye coordination and pencil control)
4. Trace the way (Pre-writing skill: hand eye coordination and pencil control)

Objectives:

- tell who are there in their families.
- identify similar and different pictures.
- hold pencil correctly and gain control over it.
- sing and enjoy the chant.

Materials:

crayons, pencils, a sample of dotted outline of a circle

Before you teach:

1. Study the workbook thoroughly.
2. Have the materials ready.

1. Listen and say

20 minutes

Activity 1

- Ask the students to look at the picture.
- Then ask simple questions. Like:
 - a. Who are there in the picture?
 - b. What are they doing? Etc.
- Ask the students who are there in their family.
- The students may not understand the question in the English language. Thus the teacher can also use the mother tongue or Nepali. Similarly, they may answer in Nepali or in their mother tongue. In such situation, translate the answer in English.

Listen and say.



He is my father.
She is my mother.
He is my brother.
She is my sister.
I love them all.



He is my father.
She is my mother.
He is my brother.
She is my sister.
I love them all.

Activity 2

- Follow the procedure suggested in lesson 1, Listen and sing, Activity 1.

2. Colour (the same picture)

15 minutes

Colour (the same picture in each row).



- Follow the procedure suggested in lesson 6, Colour the same picture.

3. Trace and colour

10 minutes

Trace and colour.

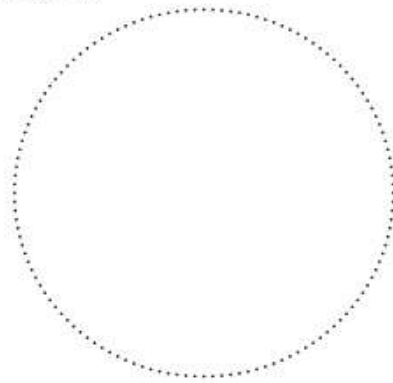

Follow the procedure suggested in lesson 6, Trace and colour.

4. Trace the way

15 minutes

Follow the procedure suggested in 'Lesson 2, Col our the way'.

Trace (the way).



Homework

Remind the students to bring their family photo for the next day.

Lesson 9

In this lesson, there are four topics to cover:

1. Listen and say (Listening and speaking)
2. Colour the same picture (Pre-reading: recognition)
3. Trace and colour (Pre-writing skill: hand eye coordination and pencil control)
4. Trace the way (Pre-writing skill: hand eye coordination and pencil control)

Objectives:

- say the words; father, mother, brother and sister orally.
- introduce family members using pictures/photographs
- identify similar and different pictures.
- hold pencil correctly and gain control over it.

Materials:

pictures / photograph of family, crayons, pencils, a sample of dotted outline of a half circle

Before you teach:

1. Study the workbook thoroughly.
2. Have the materials ready.

1. Listen and say

20 minutes

Activity 1

- Ask the students to look at the picture.
- Then ask them who they are.
- The students may not understand the question in the English language. Thus the teacher can also use the mother tongue or Nepali. Similarly, they may answer in Nepali or in their mother tongue. In such situation, translate the answer in English.
- Show the picture of father and say the word 'father'. Ask the students to follow you.
- Conduct whole class drill and small group drill.
- After this, show the picture and ask some students to name the picture individually.

Listen and say.



father



mother



brother



sister

- Repeat the same process for other pictures too.

Activity 2

- Show your family photo to the students and tell them father, mother, brother and sister showing the photograph.
- Now ask each student to come to the front of the class with his/her family photo/ provide a family picture.
- Tell him/her to show the photo/picture to their friends and say who are there in the photograph.

2. Colour (the same picture)

15 minutes

- Follow the procedure suggested in "Lesson 6, Colour the same picture'.

Colour (the same picture in each row).

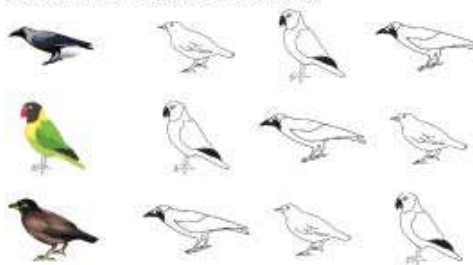

3. Trace and colour

15 minutes

Follow the procedure suggested in 'Lesson 6, Trace and colour'.

Trace and colour.



4. Trace the way

10 minutes

Follow the procedure suggested in 'Lesson 2, Colour the way'.

Trace (the way).



Homework

Learn the words: father, mother, brother and sister with the help of your senior.

Lesson 10

In this lesson, there are four topics to cover:

1. Listen and say (Listening and speaking)
2. Colour the same picture (Pre-reading: recognition)
3. Trace and colour (Pre-writing skill: hand eye coordination and pencil control)
4. Trace the way (Pre-writing skill: hand eye coordination and pencil control)

Objectives:

- say the words; father, mother, brother and sister orally.
- identify similar and different pictures.
- hold pencil correctly and gain control over it.

Materials:

crayons, pencils, a sample of dotted outline of a cone

Before you teach:

1. Study the workbook thoroughly.
2. Have the materials ready.

1. Listen and say

20 minutes

Activity 1

- Ask the students to look at the picture.
- Then ask them who they are.
- Also ask them who are there in their family.
- The students may not understand the question in the English language. Thus the teacher can also use the mother tongue or Nepali. Similarly, they may answer in Nepali or in their mother tongue. In such situation, translate the answer in English.

Activity 2

Follow the procedure suggested in 'Lesson 1, Listen and sing, Activity 1'.

Listen and say.

He is my father.
She is my mother.
He is my brother.
She is my sister.
I love them all.



He is my father.
She is my mother.
He is my brother.
She is my sister.
I love them all.

2. Colour (the same picture)

15 minutes

Colour (the same picture in each row).

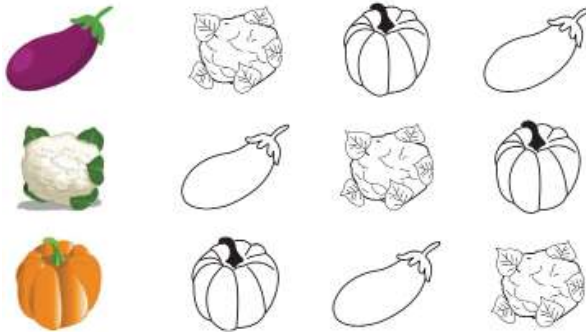

- Follow the procedure suggested in 'Lesson 6, Colour the same picture'.

3. Trace and colour

15 minutes

Trace and colour.

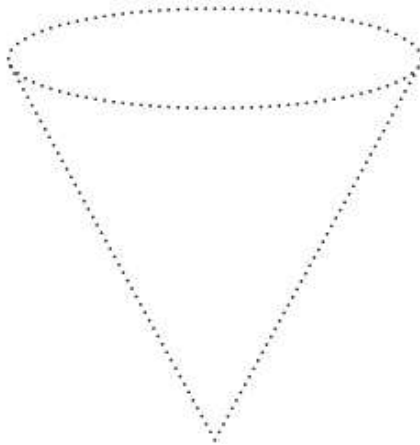

- Follow the procedure suggested in 'Lesson 6, Trace and colour'.

4. Trace the way

10 minutes

Trace (the way).



- Follow the procedure suggested in 'Lesson 2, Colour the way'.

Homework

Learn the rhyme with the help of your senior.

Lesson 11

In this lesson, there are four topics to cover:

1. Listen and say (Listening and speaking)
2. Tick the same picture (Pre-reading: recognition)
3. Join the dots (Pre-writing skill: hand eye coordination and pencil control)
4. Draw the lines (Pre-writing skill)

Objectives:

- say the words; grandfather, grandmother, uncle and aunt orally.
- identify similar and different pictures.
- hold pencil correctly and gain control over it.
- draw standing and sleeping lines

Materials:

pictures of grandfather, grandmother, uncle and aunt, and pencils,

Before you teach:

1. Study the workbook thoroughly.
2. Have the materials ready.

1. Listen and say

20 minutes

Listen and say.

He is my grandfather.
She is my grandmother.
He is my uncle.
She is my aunt.
I love them all.



grandfather grandmother
uncle aunt

- Follow the procedure suggested in lesson 10, 'Listen and say, Activity 1 and Activity 2'.

2. Colour (the same picture)

15 minutes

Tick (the same picture in each row).

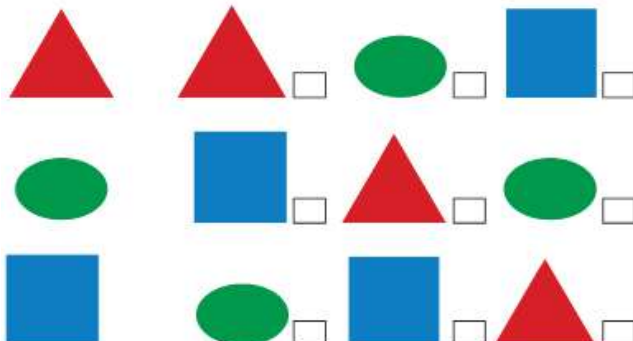

- Follow the procedure suggested in 'Lesson 6, Colour the same picture'. Here, instead of colouring the learners have to tick in the box given to the right side of the picture.

3. Join the dots

10 minutes

Join (the dots).

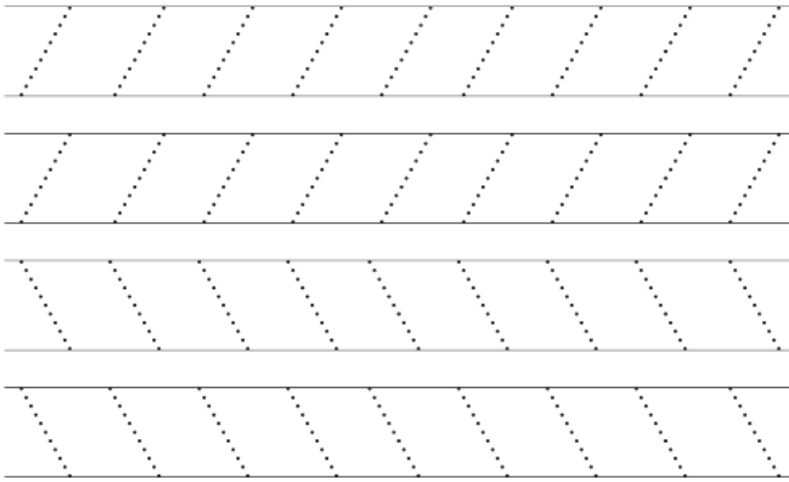

- Ask the students to hold the pencil correctly.
- Ask them to join the dots writing over the dots.
- Tell them to write from top to bottom for standing lines and left to right for the sleeping lines.
- Move around the class and help the students.

4. Draw the lines

15 minutes

Draw (the lines).

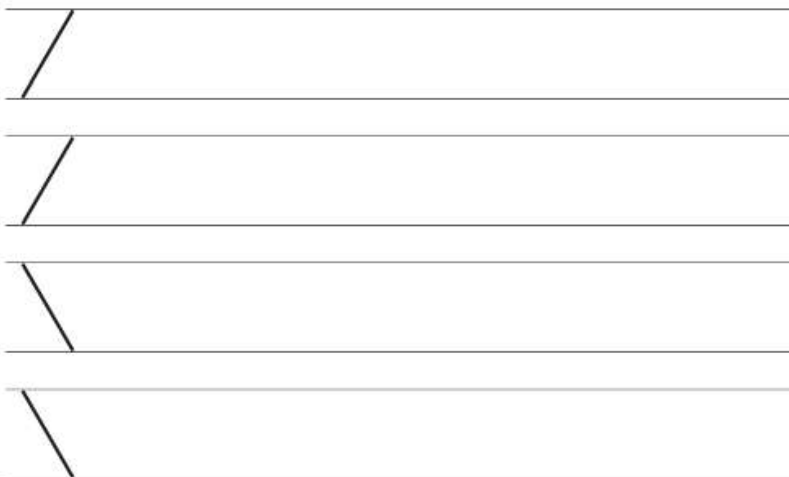

- Ask the students to hold the pencil correctly and draw the standing lines from top to bottom in the first two rows.
- Ask them to draw sleeping lines from left to right in the next two rows.
- Move around the class and help them.

Homework

Draw standing lines and sleeping lines with the help of your senior.

Lesson 12

In this lesson, there are four topics to cover:

1. Listen and act (Listening and speaking)
2. Tick the same picture (Pre-reading: recognition)
3. Join the dots (Pre-writing skill: hand eye coordination and pencil control)
4. Draw the lines (Pre-writing skill)

Objectives:

- produce the sounds of different animals
- identify similar and different pictures.
- hold pencil correctly and gain control over it.
- draw the slant lines.

Materials:

animal puppets, pencils,

Before you teach:

1. Study the workbook thoroughly.
2. Have the materials ready.

1. Listen and act

20 minutes

Activity 1

- Ask the students to look at the picture and ask the questions.
 - a. What do you see in the picture?
 - b. What are they doing? Etc.
- The students may not understand the questions in the English language. Thus the teacher can also use the mother tongue or Nepali. Similarly, they may answer in Nepali or in their mother tongue. In such situation, translate the answer in English.

Listen and act.

Cow says moo moo
Goat says maa maa
Dog says bow wow
Cat says meow meow
All animals say hello.



Activity 2

- Tell students that you are going to sing a song for them.
- Ask them to listen to you.
- Sing the rhyme while the students listen to you. Use the puppets of the animals

in the picture and act like them while singing.

- After you sing it a couple of times, ask them to repeat after you.
- Do it several time with actions.
- You need to continue until everyone gets the rhyme.
- Then, provide the puppets to the students and ask them to sing in the same way as you did.
- Tell the name of the animals and ask the students to produce the sound.

2. Colour (the Same Picture)

15 minutes

Tick (the same picture in each row).

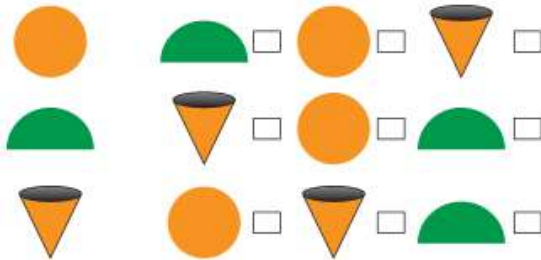

- Follow the procedure suggested in lesson 11, Colour the same picture.

3. Join the dots

15 minutes

Join (the dots).

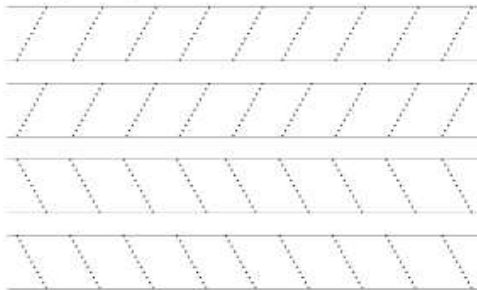

- Ask the students to hold the pencil correctly.
- Ask them to join the dots writing over the dots.
- Tell them to write from right to left for the first two rows and left to right for the last two rows.
- Move around the class and help the students.

4. Draw the lines

10 minutes

Draw (the lines).



- Ask the students to hold the pencil correctly and draw the standing lines from right to left in the first two rows.
- Ask them to draw the lines from left to right in the last two rows.
- Move around the class and help them.

Homework

Learn the sounds of different animals with the help of your senior.

Lesson 13

In this lesson, there are four topics to cover:

1. Listen and act (Listening and speaking)
2. Tick the same picture (Pre-reading: recognition)
3. Join the dots (Pre-writing skill: hand eye coordination and pencil control)
4. Draw the lines (Pre-writing skill)

Objectives:

- produce the sounds of different animals
- identify similar and different pictures.
- hold pencil correctly and gain control over it.
- draw curves

Materials:

animal puppets, pencils,

Before you teach:

1. Study the workbook thoroughly.
2. Have the materials ready.

1. Listen and act

20 minutes

Activity 1

- Ask the students to look at the picture and ask them the following questions.
 - a. What do you see in the picture?
 - b. What are they doing? Etc.
- The students may not understand the questions in the English language. Thus the teacher can also use the mother tongue or Nepali. Similarly, they may answer in Nepali or in their mother tongue. In such situation, translate the answer in English.

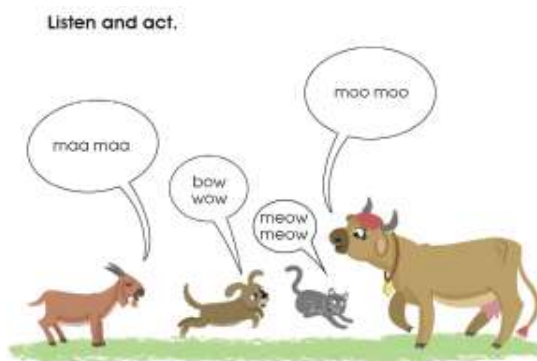

Activity 2

- Use the puppet of an animal given in the picture and produce the sound of the animal.
- Ask the students to follow you.
- Once you produce the sound of all the animals given in the picture ask the

students to produce the sound themselves.

- Tell the name of an animal and ask the students to produce the sound of that animal.
- Produce the sound of an animal and ask them to guess the animal.

2. Tick (the same picture) 15 minutes

- Follow the procedure suggested in 'Lesson 11, Colour the same picture'.

Tick (the same picture in each row).

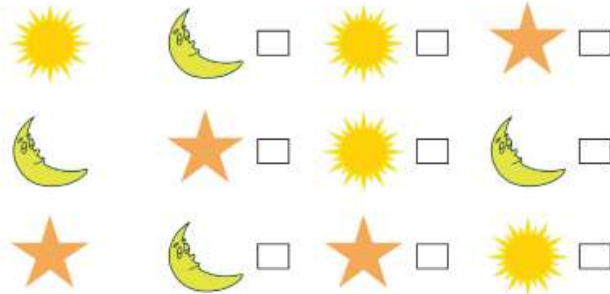

3. Join the dots 10 minutes

- Ask the students to hold the pencil correctly.
- Ask them to join the dots writing over the dots.
- Move around the class and help the students.

Join (the dots).

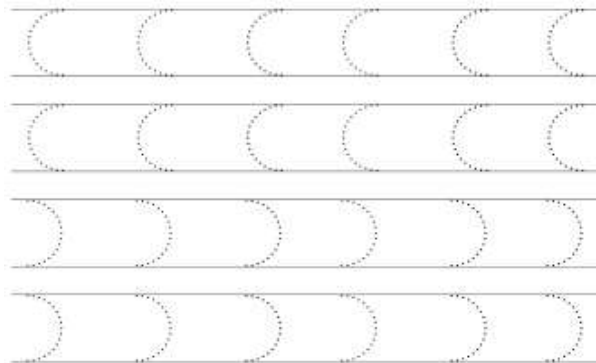

4. Draw the lines 15 minutes

- Ask the students to hold the pencil correctly.
- Ask them to draw the lines as indicated.
- Move around the class and help them.

Draw (the lines).



Homework

Learn the sounds of different animals with the help of your senior.

Lesson 14

In this lesson, there are four topics to cover:

1. Listen and act (Listening and speaking)
2. Tick the same line (Pre-reading: recognition)
3. Join the dots (Pre-writing skill: hand eye coordination and pencil control)
4. Draw the lines (Pre-writing skill)

Objectives:

- produce the sounds of different animals
- identify similar and different lines.
- hold pencil correctly and gain control over it.
- draw T and O shapes.

Materials:

animal puppets, pencils

Before you teach:

1. Study the workbook thoroughly.
2. Have the materials ready.

1. Listen and act

20 minutes

Activity 1

- Ask the students to look at the picture and ask the following questions.
 - a. What do you see in the picture?
 - b. What are they doing? Etc.
- The students may not understand the questions in the English language. Thus the teacher can also use the mother tongue or Nepali. Similarly, they may answer in Nepali or in their mother tongue. In such situation, translate the answer in English.

Listen and act.



Activity 2

- Use animal puppets in the picture and tell the students what they are doing.
- Tell the name of an animal in the picture and ask the students act what they are doing in the picture.

2. Tick (the Same Line)

10 minutes

Tick (the same line in each row).

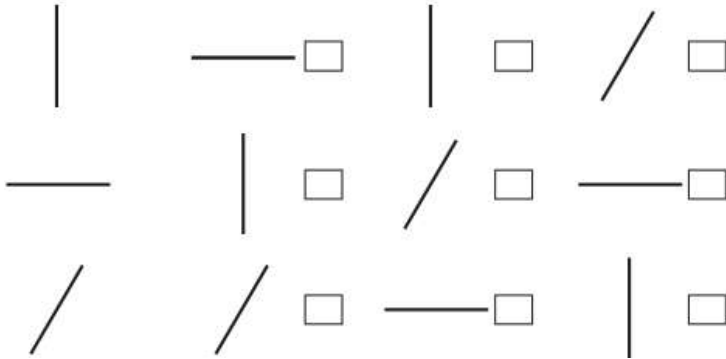

- Follow the procedure suggested in lesson 11, Colour the same picture.

3. Join the dots

10 minutes

Join (the dots).

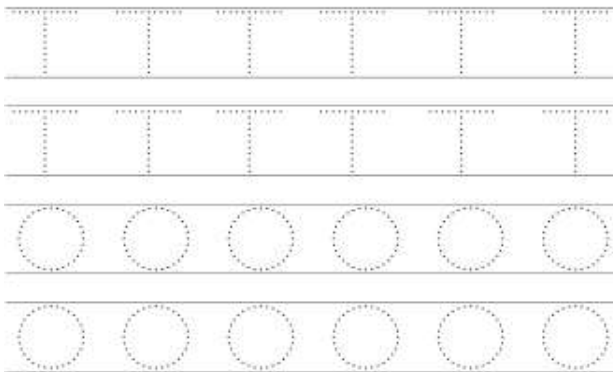

- Ask the students to hold the pencil correctly.
- Ask them to join the dots writing over the dots.
- Move around the class and help the students.

4. Draw the shapes

20 minutes

Draw (the shapes).

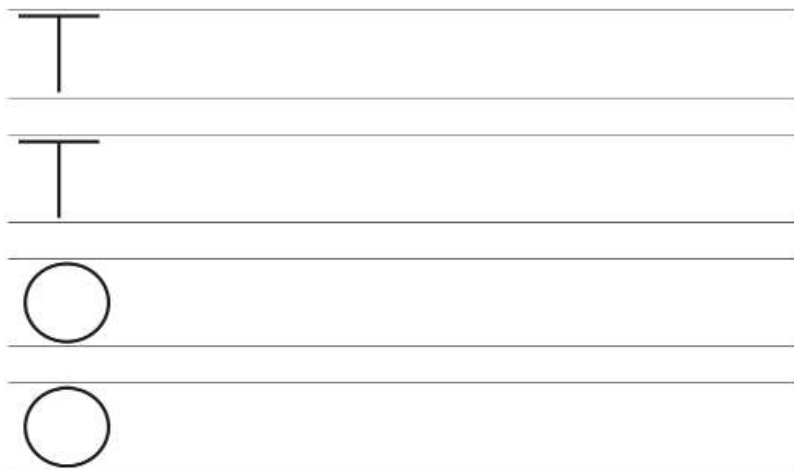

- Ask the students to hold the pencil correctly.
- Ask them to draw the lines as indicated.
- Move around the class and help them.

Homework

Learn to draw the T and O shapes with the help of your senior.

ASSESS YOURSELF

This is the assessment section of the theme. The tasks are given in the workbook for this theme. Do it in class.

- Ask the students to do this task individually. You say each sentence, and the students repeat the sentences after you and act what is said in the sentence. Listen to the pronunciation and observe.
- The students will do the task individually. Ask the student to point to the similar pictures in each row.

1. Listen and say after the teacher.
 a. Good morning.
 b. Good morning teacher.
 c. Hello!
 d. Bye!

2. Point! (to the same pictures).



- Do this task individually too. Say 'I am ...your name and ask the students to do the same. Similarly say the expressions 'Bye!' and 'Hello!' And ask the student to follow you.
- Students do this task in whole group.
- Read the rhyme yourself and ask the students to follow you.

3. Listen and act.



4. Listen and sing.

Two big apples
 Under a tree.
 One is for you
 And one is for me.



- Do this task individually.
- Ask the students join the dots writing over them.
- Check their work.

5. Join (the dots).

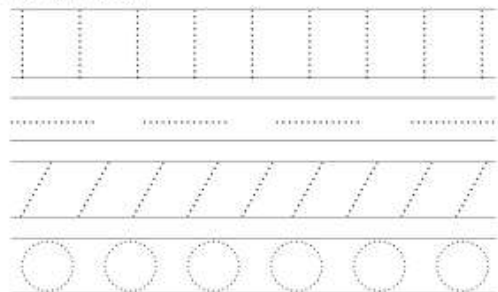

Theme: Alphabet

This theme ensures the learning of the English Alphabets. Along with this, they will develop phonemic and graphophonemic awareness, learn to pronounce, read and write letters in English alphabet, follow model reading to develop reading fluency, learn some decodable words. They will also learn to trace and write the letters.

Number of Lessons: 58

Lesson Topics

1. Lesson 15 – 25 (Aa - Ee)
2. Lesson 26 – 36 (Ff - Jj)
3. Lesson 37 – 47 (Kk - Oo)
4. Lesson 48 – 58 (Pp - Tt)
5. Lesson 59 – 71 (Uu - Zz)
6. Lesson 72 (Revision: Aa - Zz)

Soft skills

- Problem solving
- Active listening
- Team work
- Communication

Language function

- Talking about days of the week
- Expressing ability
- Telling the time

Skill-wise objectives

Listening

Listening

- Imitate, identify and discriminate sounds.
- Identify words that have the same initial, medial or final sound.
- Blend individual sounds in simple one-syllable words. (e.g. /s/ /i/ /t/ →sit)
- Recognize, identify and produce rhyming words. (e.g. cat →bat, sat)
- Link an initial sound to a picture of an object that begins with that sound (e.g. Show a picture of a book and identify the initial sound /b/).

- Name a printed letter that matches a sound (e.g. the teacher says /t/ and the student points to the /t/ letter).
- Match spoken words to printed words (e.g. the teacher pronounces /pin/, and the student selects pin from a set of three word cards).
- Recognize and comprehend words and simple expressions.
- Respond to the audio or the teacher non-verbally and verbally.

Speaking

- Imitate and produce sounds and words.
- Blend the initial sounds with other sounds, i.e. onset with rime. (e.g. c+at).
- Pronounce grade appropriate words correctly.
- Ask and answer short, simple questions.
- Sing or recite a song/chant by listening to the teacher or an audio.

Reading

- Read small and capital letters.
- Put sounds together to read words and sentences.
- Recognize and read familiar words accompanied by visuals.
- Perform rhymes and chants with appropriate rhyme and rhythm.
- Understand the meaning of grade appropriate words.

Writing

- Hold pencil correctly to gain control to draw lines, curves and circles, etc.
- Develop hand-eye coordination through drawing lines and patterns.
- Trace the letters and write them.
- Form lower and upper case letters of regular size and shape.
- Demonstrate good handwriting skills.

Lesson 15

Aa

In this lesson, there are six topics to cover:

1. Listen and say (Listening and speaking)
2. Look and discuss (Listening and speaking)
3. Listen and say (Listening, speaking and reading)
4. Colour (Reading)
5. Colour the apples with letter 'a' (Reading)
6. Write (Writing)

Objectives:

- Say the words: father, mother and sister orally.
- Say the words that have the letter 'a' in initial position.
- Draw a picture of an ant using the letter 'a'.
- Identify the letter 'a'.
- Trace over letter 'Aa'.

Materials:

Pictures: father, mother, sister, ant, aeroplane, apple and arrow, crayons/colouring pens

Before you teach:

1. Study the workbook thoroughly.
2. Have the materials ready.

1. Listen and say

5 minutes

- Show the pictures of father, mother, and sister one by one and ask the students to guess who they are.
- Show the picture of father and say the word 'father' and ask the students to follow you.
- Repeat the same process for other words; mother and sister too.



2. Look and discuss

5 minutes

- Ask the students to look at the picture.
- Ask them: What do you see in the picture.
- Try to elicit the words; apple, ant and alligator.
- For this you can point to a particular picture.
- You can ask the question in Nepali language or



in their first language if they do not understand. Similarly they may answer in Nepali. In such situation, translate their answer into English.

3. Listen and say 15 minutes

- Bring in the pictures of an ant, an aeroplane, an apple and an arrow (or you can display the pictures from the workbook.).
- Touch one picture, e.g. the picture of the ant, and get the students to name the picture. They may say in their mother tongue or they may not be able to name. If they can't help them.
- Do similar activity for the rest of the pictures.
- Conduct the activity in the reverse order: Say the word 'ant' and ask the students to touch the picture of 'ant'. Continue the similar procedure for other pictures, too.



4. Colour 15 minutes

- Provide a set of crayons/ colouring pens. Display the picture to the class.
- Chose a dark red colour (or a brown one), and model colouring the outline picture of the ant.
- Follow the steps of colouring from the front to the back.
- Now ask the students to colour in the same way.
- Help them to choose an appropriate colour.
- Monitor their activities; after they complete colouring ask them to show it to their friends.
- Complement their work.

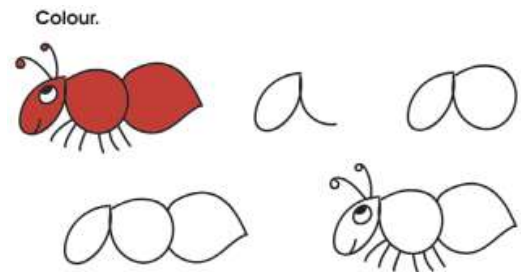

5. Colour the apples with letter 'a'. 10 minutes

- Conduct this task individually.
- First ask the students to see which apples have the letter 'a'.
- Once they recognize ask them to colour those apples as shown there.

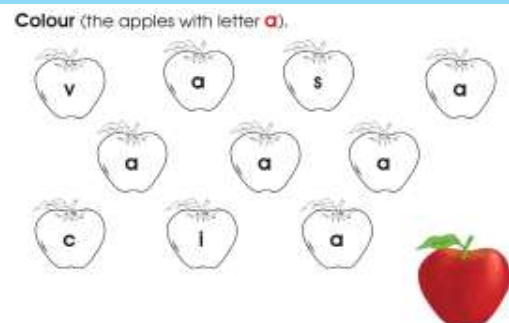

6. Write.

10 minutes

1. Conduct this task individually.
2. Draw a four-line frame on the board.
3. Display the stages for writing the letter 'A' as shown by the strokes. Show the palm movements clearly.
4. Ask the students to write over the dots for the upper case 'A' at three stages as mentioned above.
5. Display the stages for writing the lower case letter 'a', as shown by the arrows. Show the palm movements clearly.
6. Ask the students to write over the dots for the lower case 'a' at two stages as mentioned above.
7. Move around the class and help them.

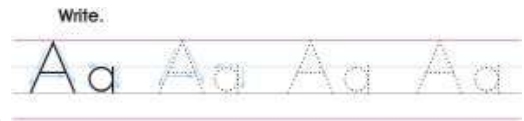

Homework

- Write the letters 'A' and 'a' with the help of your seniors.

Lesson 16

Aa

In this lesson, there are seven topics to cover:

1. Read (Reading)
2. Look and say (Listening, speaking and reading)
3. Write (Writing)
4. Listen and sing
5. Look and discuss (Listening and speaking)
6. Circle (Listening and speaking)
7. Copy (Writing)

Objectives:

- Read the letter 'a'.
- Say the words that have 'a' in initial position.
- Trace and write the letters 'A' and 'a'.
- Sing and enjoy a chant.

Materials:

Pictures (apple, ant, aeroplane), word cards (apple, ant and aeroplane; highlighting the initial letter 'a'.)

Before you teach:

1. Study the workbook thoroughly.
2. Have the materials ready.

1. Read. 5 minutes

- Read out each letter with correct pronunciation. Read.
a a a a a
- Get the students to repeat after you.
- Ensure that the students have understood the sounds of the alphabets they stand for.
- Ask the students to identify the alphabets and pronounce correctly.

2. Look and say. 15 minutes

- Provide a model reading touching the alphabet 'a' and saying its sound /a/. (For word- level activities, read both the individual letter- sound and the entire word as a model.)



- Ask the students to do the same, i.e. touch the alphabet and say its sound /a/.
- Display the picture set.
- Touch the picture of 'apple', and say /æ/, /æ/ and finally /æpəl/. Invite the students to do the same: say the sound / æ / and the word 'apple'
- Follow the similar procedure for the pictures and words: 'ant' and 'aeroplane'.

3. Write.

10 minutes

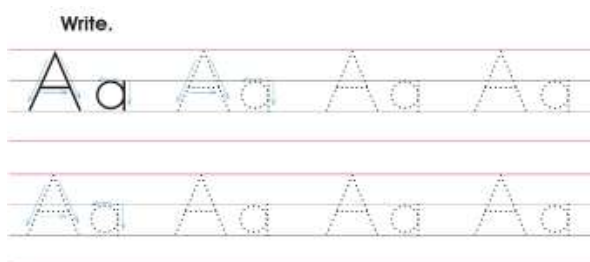

- Follow the procedure as suggested in lesson 15, 'Write'.

4. Listen and sing

10 minutes

- Tell students that you are going to sing a song for them.
- Ask them to listen to you.
- Sing the rhyme while the students listen to you.
- After you sing it a couple of times, ask them to repeat after you.
- Do it several times with actions.
- You need to continue until everyone gets the rhyme.

Listen and sing.
Up in the apple tree
High off the ground
I see an apple
Big and round.



5. Look and discuss.

5 minutes

Look and discuss.



- Follow the procedure as suggested in 'Lesson 15, 'Look and discuss'.

6. Circle

5 minutes

1. Conduct this task individually.
2. Ask the students to see which of the pictures are there in the above picture.
3. Ask them to circle the picture if they find it in

Circle (the objects found in the picture above).



the picture given in the section 'Look and discuss.

4. Move around the class and help them.

7. Copy

10 minutes

1. Draw a four-line frame on the board.
Copy. 
2. Display the stages for writing the letter 'A', as shown by the strokes in the workbook. Show the palm movements clearly.
3. Ask the students to write the letter 'A' in the same way.
4. Display the stages for writing the lower case letter 'a', as shown by the strokes in the workbook. Show the palm movements clearly.
5. Ask the students to write the lower case 'a' in the same way.
6. Ask them to fill all the given space.
7. Move around the class and monitor while they write.
8. Help them if it is necessary.

Homework

- Write the letters 'A' and 'a' with the help of your seniors.

Lesson 17

Bb

In this lesson, there are six topics to cover:

1. Look and say (Listening and speaking)
2. Look and discuss (Listening and speaking)
3. Listen and say (Listening, speaking and reading)
4. Colour (Reading)
5. Listen and sing
6. Write (Writing)

Objectives:

- Say the words: apple, ant and aeroplane orally.
- Say the words that have the letter 'b' in initial position.
- Draw a picture of a ball using the letter 'B'.
- Sing and enjoy a rhyme.
- Trace over letter 'Bb'.

Materials:

Pictures: ant, aeroplane, apple, bag, ball, book, and blue colour, crayons/colouring pens

Before you teach:

1. Study the workbook thoroughly.
2. Have the materials ready.
3. Learn to sing the rhyme 'Baa, baa, black sheep'. (<https://www.youtube.com/watch?v=i7ygKQunfmE>)

1. Look and say

5 minutes

- Show the pictures one by one and ask the students to name the pictures.
- If they can't, say yourself and ask them to follow you.

Look and say.



2. Look and discuss

5 minutes

- Follow the procedure suggested in 'Lesson 15, 'Look and discuss'.

Look and discuss.



3. Listen and say

15 minutes

Listen and say.



b



- Follow the procedure suggested in 'Lesson 15, 'Listen and say'.

4. Colour

15 minutes

Colour.

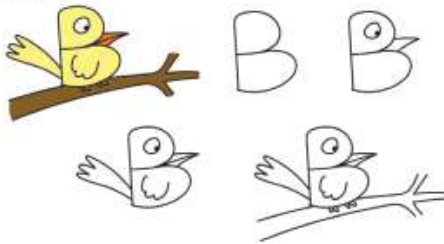

- Follow the procedure suggested in 'Lesson 15, 'Colour'.

5. Listen and sing

10 minutes

Listen and sing.

Baa, baa, black sheep,
Have you any wool?
Yes sir, yes sir,
Three bags full.
One for the master,
And one for the dame,
And one for the little boy,
Who lives down the lane.



- Follow the procedure suggested in 'Lesson 16, 'Listen and sing'.

6. Write

10 minutes

Write.

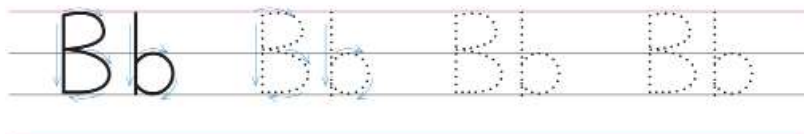

1. Follow the procedure suggested in lesson 15, 'Write'.

Homework

- Draw a picture of a ball and colour it.

Lesson 18

Bb

In this lesson, there are six topics to cover:

1. Read (Reading)
2. Look and say (Listening, speaking and reading)
3. Write (Writing)
4. Look and discuss (Listening and speaking)
5. Circle (Listening and speaking)
6. Copy (Writing)

Objectives:

- Read the letters 'a' and 'b'.
- Say the words that have 'b' in initial position.
- Trace and write the letters 'B' and 'b'.

Materials:

Pictures (ball, book and banana), word cards (ball, book and banana; highlighting the initial letter 'b'.)

Before you teach:

1. Study the workbook thoroughly.
2. Have the materials ready.

1. Read 5 minutes

- Follow the procedure **Read.** suggested in 'Lesson 16 'Read'

b a b a b

2. Look and say 15 minutes

Look and say.

Bb

ball



book



banana



- Follow the procedure suggested in lesson 16, 'Look and say'.

3. Write

10 minutes

- Follow the procedure as suggested in lesson 15, 'Write'.

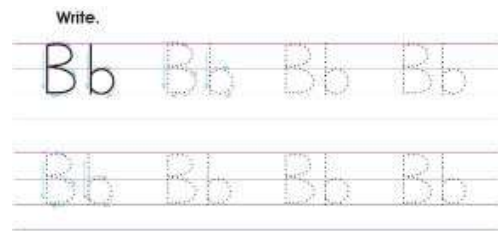

4. Look and discuss

10 minutes

- Follow the procedure as suggested in lesson 15, 'Look and discuss'.

Look and discuss.



5. Circle

10 minutes

- Follow the procedure as suggested in lesson 16, 'Circle'.

Circle (the objects found in the picture above).



6. Copy

10 minutes

- Follow the procedure as suggested in 'Lesson 16, 'Copy'.



Homework

- Write the letters 'B' and 'b' with the help of your seniors.

Lesson 19

Cc

In this lesson, there are six topics to cover:

1. Look and say (Listening and speaking)
2. Look and discuss (Listening and speaking)
3. Listen and say (Listening, speaking and reading)
4. Colour (Reading)
5. Match (Reading)
6. Write (Writing)

Objectives:

- Say the words: bag, ball and book orally.
- Say the words that have the letter 'c' in initial position.
- Draw a picture of a cat using the letter 'c'.
- Identify pictures that match with letters.
- Trace over letter 'Cc'.

Materials:

Pictures: bag, ball, book, cat, cap, car and cock, crayons/colouring pens

Before you teach:

1. Study the workbook thoroughly.
2. Have the materials ready.

1. Look and say

5 minutes

- Show the pictures one by one and ask the students to name the pictures.
- If they can't, say yourself and ask them to follow you.

Look and say.



2. Look and discuss

5 minutes

- Follow the procedure suggested in 'Lesson 15, Look and discuss'.

Look and discuss.



3. Listen and say

15 minutes

Listen and say.



- Follow the procedure suggested in 'Lesson 15, Listen and say'.

4. Colour

15 minutes

Colour.

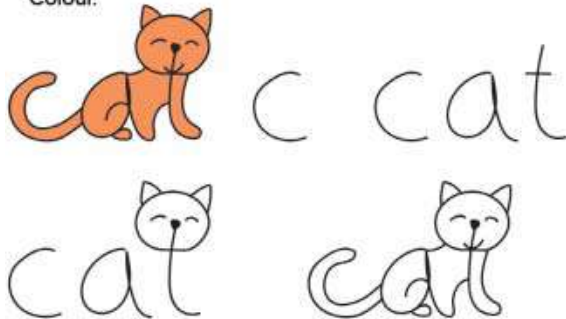

- Follow the procedure suggested in 'Lesson 15, Colour'.

5. Match

10 minutes

Match (the pictures with the letters).



Aa



Bb



Cc



- Do this task individually.
- Ask the students to match the pictures with their initial letters.
- Move around and help them.

6. Write

10 minutes

Write.

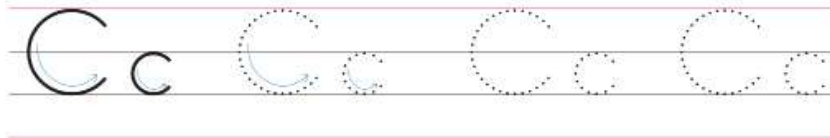

- Follow the procedure suggested in 'Lesson 15, Write'.

Homework

- Draw a picture of a cat and colour it.

Lesson 20

Cc

In this lesson, there are six topics to cover:

1. Read (Reading)
2. Listen and sing (Listening and speaking)
3. Look and say (Listening, speaking and reading)
4. Write (Writing)
5. Look and discuss (Listening and speaking)
6. Circle (Listening and speaking)
7. Copy (Writing)

Objectives:

- Read the letters 'a', 'b' and 'c'.
- Sing and enjoy the phonics song.
- Say the words that have 'c' in initial position.
- Trace and write the letters 'C' and 'c'.

Materials:

Pictures (cup, cap, cat), word cards (cup, cap, cat; highlighting the initial letter 'c'.)

Before you teach:

1. Study the workbook thoroughly.
2. Have the materials ready.
3. Learn to sing the phonics song 'C is for cat k k cat.' (<https://www.youtube.com/watch?v=BELIZKpi1Zs>)

1. Read

5 minutes

Read.

b **c** **a** **b** **c**

- Follow the procedure suggested in 'Lesson 16, Read'.

2. Listen and sing

5 minutes

Listen and sing.

C is for cat k k cat.

C is for cap k k cap.

C is for cup k k cup.



- Follow the procedure suggested in 'Lesson 16, Listen and sing'.

3. Look and say

15 minutes



- Follow the procedure suggested in 'Lesson 16, Look and say'.

4. Write

10 minutes

- Follow the procedure as suggested in 'Lesson 15, Write'.

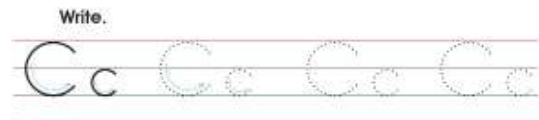

5. Look and discuss

10 minutes



- Follow the procedure as suggested in 'Lesson 15, Look and discuss'.

6. Circle

5 minutes

- Follow the procedure as suggested in 'Lesson 16, Circle'.

Circle (the objects found in the picture above).



7. Copy

10 minutes

- Follow the procedure as suggested in 'Lesson 16, Copy'.

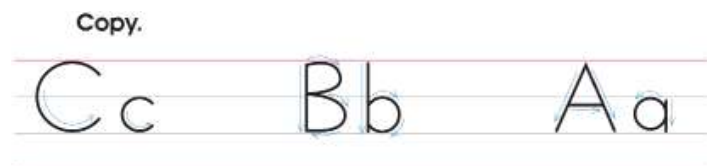

Homework

- Write the letters 'C' and 'c' with the help of your seniors.

Lesson 21

Dd

In this lesson, there are seven topics to cover:

1. Look and say (Listening and speaking)
2. Look and discuss (Listening and speaking)
3. Listen and say (Listening, speaking and reading)
4. Colour (Reading)
5. Listen and sing (Listening and speaking)
6. Colour (Reading)
7. Write (Writing)

Objectives:

- Say the words: cap, carrot and car orally.
- Say the words that have the letter 'd' in initial position.
- Draw a picture of a dinosaur using the letter 'd'.
- Sing and enjoy the phonics song.
- Recognise 'D' and 'd'.
- Trace over letter 'Dd'.

Materials:

Pictures: cap, car, carrot, duck, dog, donkey and deer, crayons/colouring pens

Before you teach:

1. Study the workbook thoroughly.
2. Have the materials ready.
3. Learn to sing the phonics song 'D is for dog d d dog'. (<https://www.youtube.com/watch?v=BELIZKpi1Zs>)

1. Look and say

5 minutes

- Show the pictures one by one and ask the students to name the pictures.
- If they can't, say yourself and ask them to follow you.



2. Look and discuss

5 minutes



- Follow the procedure suggested in 'Lesson 15, Look and discuss'.

3. Listen and say 15 minutes

Listen and say.



- Follow the procedure suggested in 'Lesson 15, Listen and say'.

4. Colour 15 minutes

Colour.

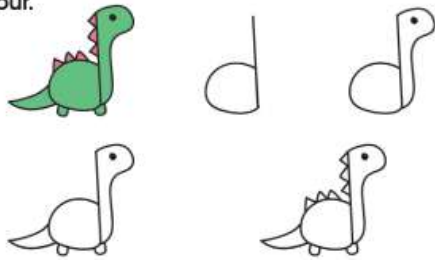

- Follow the procedure suggested in 'Lesson 15, Colour'.

5. Listen and sing 5 minutes

Listen and sing.

D is for dog d d dog.
D is for door d d door.
D is for duck d d duck.
D is for doll d d doll.



- Follow the procedure suggested in 'Lesson 16, Listen and sing'.

6. Colour the boxes having 'd' or 'D'. 5 minutes

Colour the boxes having 'd' or 'D'.

a	B	C	d	e
e	D	B	c	a
d	C	E	c	b
c	A	D	b	c

- Ask the students to see the boxes where they can find 'd' or 'D'.
- Once they find, ask them to colour the box in any colour they like.
- Conduct this task individually.

7. Write 10 minutes

Write.

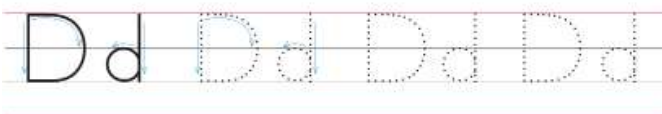

- Follow the procedure suggested in 'Lesson 15, Write'.

Homework

- Learn the phonics song 'D is for dog d d dog'.

Lesson 22

Dd

In this lesson, there are five topics to cover:

1. Read (Reading)
2. Look and say (Listening, speaking and reading)
3. Write (Writing)
4. Colour
5. Copy (Writing)

Objectives:

- Read the letters 'a', 'b', 'c' and 'd'.
- Say the words that have 'd' in initial position.
- Identify the pictures that have 'd' in initial position
- Trace and write the letters 'D' and 'd'.

Materials:

Pictures (dog, doll, door), word cards (dog, doll, door; highlighting the initial letter 'd').



Before you teach:

1. Study the workbook thoroughly.
2. Have the materials ready.

1. Read 5 minutes

- Read.
- d a c b d**
- Follow the procedure suggested in 'Lesson 16, Read'.

2. Look and say 15 minutes

- Look and say.
- Dd**
- dog 
- doll 
- door 
- Follow the procedure suggested in 'Lesson 16, Look and say'.

3. Write 10 minutes

- Write.
- Dd Dd Dd Dd**
- Dd Dd Dd Dd**
- Follow the procedure as suggested in 'Lesson 15, Write'.

4. Colour the picture that begins with the letter 'd'. 20 minutes

- Ask the students to name the picture in each set.
- If they can't, help them.
- Once they know the names of pictures, ask them which of them begins with letter d.
- When they recognize the picture that has the letter 'd' in initial position, ask them to colour it individually.

Colour (the picture that begins with the letter **d**).

1. door and key

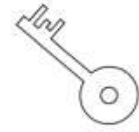
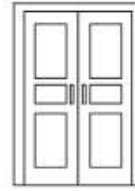

2. donkey and monkey

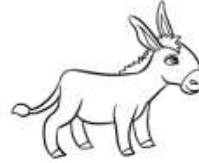

3. dog and cat



5. Copy

10 minutes

- Follow the procedure as suggested in 'Lesson 16, Copy'.

Copy.

Bb

Cc

Aa

Dd

Homework

- Write the letters 'D' and 'd' with the help of your seniors.

Lesson 23

Ee

In this lesson, there are six topics to cover:

1. Look and say (Listening and speaking)
2. Look and discuss (Listening and speaking)
3. Listen and say (Listening, speaking and reading)
4. Colour (Reading)
5. Find and trace (Reading)
6. Write (Writing)

Objectives:

- Say the words: duck, donkey, drum orally.
- Say the words that have the letter 'e' in initial position.
- Draw a picture of an elephant using the letter 'e'.
- Sing and enjoy the phonics song.
- Recognise 'e'.
- Trace over letter 'Ee'.

Materials:

Pictures: duck, donkey, drum, elephant, eye, eagle and egg, crayons/colouring pens

Before you teach:

1. Study the workbook thoroughly.
2. Have the materials ready.

1. Look and say

5 minutes

- Show the pictures one by one and ask the students to name the pictures.
- If they can't, say yourself and ask them to follow you.

Look and say.



2. Look and discuss

5 minutes

- Follow the procedure suggested in 'Lesson 15, Look and discuss'.

Look and discuss.



3. Listen and say. 15 minutes

- Follow the procedure suggested in 'Lesson 15, Listen and say'.

Listen and say.



4. Colour

15 minutes

Colour.



- Follow the procedure suggested in 'Lesson 15, Colour'.

5. Find and trace the way

10 minutes

Find and trace (the way).

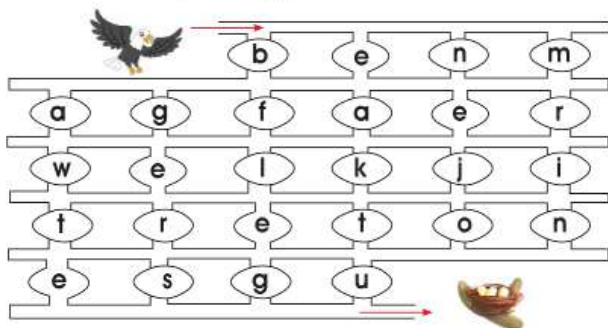

- Do this task individually.
- Ask the students to see where the eagle is and where its nest is.
- Tell them that they have to follow letter 'e' to reach to the nest.
- Ask them to begin as indicated by the arrow.
- Move around the class and help them.

6. Write

10 minutes

Write.

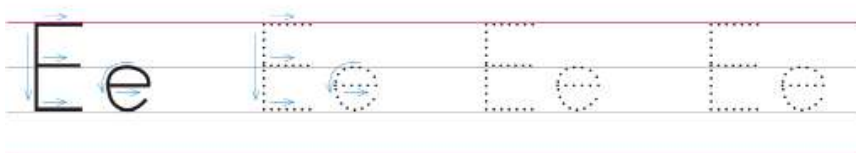

- Follow the procedure suggested in 'Lesson 15, Write'.

Homework

- Draw the picture of an elephant using the letter 'E'.

Lesson 24

Ee

In this lesson, there are six topics to cover:

1. Read (Reading)
2. Look and say (Listening, speaking and reading)
3. Write (Writing)
4. Read (Reading)
5. Colour (Reading)
6. Copy (Writing)

Objectives:

- Read the letters 'a', 'b', 'c', 'd' and 'e'.
- Say the words that have 'e' in initial position.
- Identify the pictures that have 'e' in initial position
- Read the words correctly.
- Trace and write the letters 'E' and 'e'.

Materials:

- Letter cards (a -e)
- Pictures (elephant, eye, ear)
- Word cards (elephant, eye, ear; highlighting the initial letter 'e'.)

Before you teach:

1. Study the workbook thoroughly.
2. Have the materials ready.

1. Read 5 minutes

Read.

e a d b c

- Show the letter cards one by one and ask the students to read the letter on the card.
- If they can't, read yourself and ask them to follow you.

2. Look and say 15 minutes

Look and say.



- Follow the procedure suggested in 'Lesson 16, Look and say'.

3. Write 10 minutes

- Follow the procedure as suggested in 'Lesson 15, Write'.

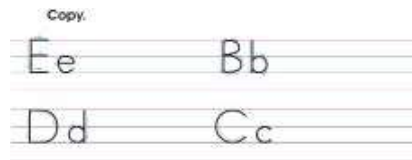

4. Read 10 minutes

- Pick the alphabet cards that make the word 'bed'.
- Ask the students to read the letters.
- Put the cards together saying the sounds /b/, /e/ and /d/ and ask the students to follow you.
- Read the word /bed/ and ask the students to follow you.
- Repeat the similar procedure for the word 'bee' too.
- Divide the students in small groups of 4/5.
- Provide a set of letter cards to each group and ask them to make a word putting the cards together.
- Ask them to read the word loud.

Colour (the picture that starts with e).

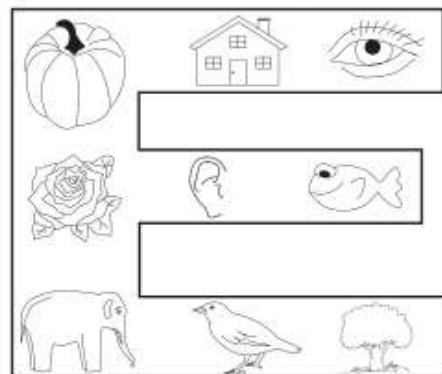

5. Colour the picture that starts with 'e'. 10 minutes

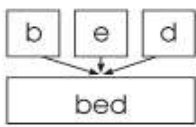
- Ask the students to name the pictures. **Read.** Point one picture at a time and ask them to name.

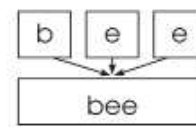
- Speak out the word for a picture. Elicit from the students asking 'Which picture has 'e' in the beginning?'
- When the students have recognized the pictures that have the names with the letter 'e' in the beginning, ask them to colour those pictures.
- Ask them to do individually.



6. Copy 10 minutes

- Follow the procedure as suggested in 'Lesson 16, Copy'.

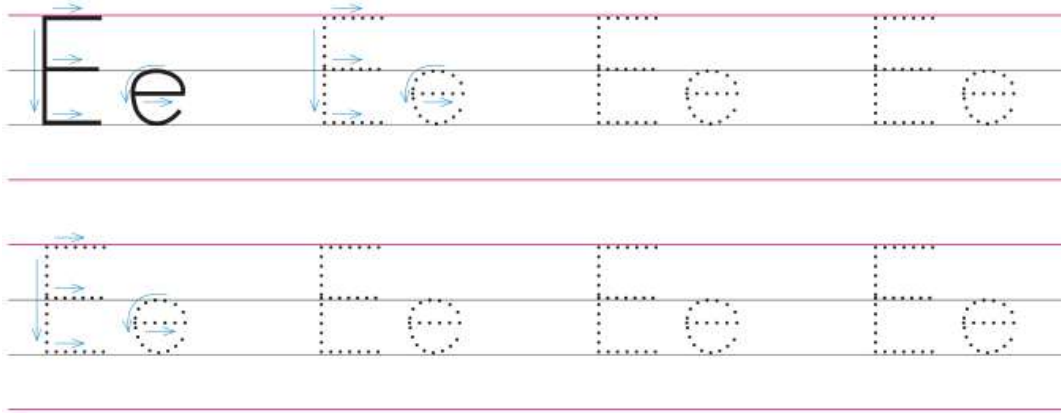
Write.



Homework

- Write the letters 'E' and 'e' with the help of your seniors.

Lesson 25

Aa - Ee

In this lesson, there are four topics to cover:

1. Look and say (Listening, speaking and reading)
2. Write (Writing)
3. Read and match (Reading)
4. Write correct words (Writing)

Objectives:

- Say the words that have ' a - e' in initial position.
- Blend onset with rime.
- Discriminate sounds.
- Write a- e.
- Unscramble the jumble words.

Materials:

- Picture and word cards: apple, ant, arm, ball, bag, book, cat, cap, car, dog, duck, doll, egg, eye and ear in which the initial letter is highlighted

Before you teach:

1. Study the workbook thoroughly.
2. Have the materials ready.

1. Look and say

30 minutes



- Follow the procedure suggested in 'Lesson 16, Look and say'.

2. Write

10 minutes

- Ask the students to look at the pictures and name them.
- Help them if they can't.



- Once they learn the name, ask them: Which letter is missing?
- Tell them that, they have to fill the initial letter in each blank space.
- Move around the class and help them while they are doing the task.
- After they complete, check it thoroughly.

3. Read and match

10 minutes

- Read the words in a set. Ask the students to follow after you.
- Show the picture.
- Elicit whether the students can recognize the picture. If they can't help them.
- Ask the students to read the words in the set, and recognize the correct picture.
- Ask them to draw the lines from the picture to the word.
- Move around the class helping them when they do the task.

Read and match.



book
bee
ball



bag
bed
bread



cap
cat
cab

4. Write correct words

10 minutes

- Ask the students to name the picture.
- Help them if they can't.
- Once they know the name, ask them to write it in the blank spaces given alongside.
- Tell them to use the letters given by the side of the pictures.
- Tell them to do the task individually.

Write correct words.



bde

.....



ebe

.....



cba

.....

Homework

- Write the letters Aa - Ee.

Lesson 26

Ff

In this lesson, there are six topics to cover:

1. Listen and say (Listening and speaking)
2. Look and discuss (Listening and speaking)
3. Listen and say (Listening, speaking and reading)
4. Colour (Reading)
5. Listen and sing
6. Write (Writing)

Objectives:

- Say the words: bed, bee, cab and dad orally.
- Say the words that have the letter 'f' in initial position.
- Draw a picture of a fish using the letter 'F'.
- Sing and enjoy the rhyme.
- Trace over letter 'Ee'.

Materials:

Word cards: bed, bee, cab, dad and picture cards: fish, flag, frog and fox

Before you teach:

1. Study the workbook thoroughly.
2. Have the materials ready.
3. Learn to sing the rhyme (<https://www.youtube.com/watch?v=HqOUkXtYaU4>)

1. Listen and say

5 minutes

- Show the word cards one by one and ask the students to read the words. Listen and say.
bed bee cab dad
- If they can't, read yourself and ask them to follow you.

2. Look and discuss

5 minutes

Look and discuss:



- Follow the procedure suggested in 'Lesson 15, Look and discuss'.

3. Listen and say

15 minutes

Listen and say.



- Follow the procedure suggested in 'Lesson 15, Listen and say'.

4. Colour

15 minutes

Colour.

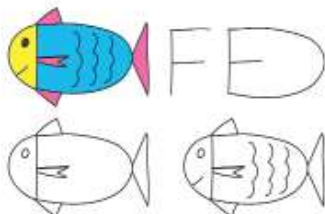

- Follow the procedure suggested in 'Lesson 15, Colour'.

5. Listen and sing

10 minutes

Listen and sing.

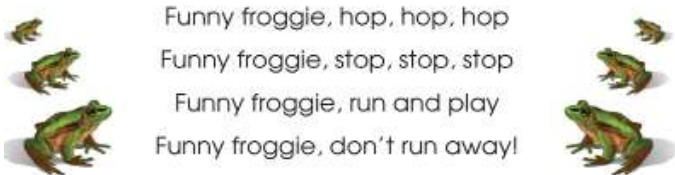

- Follow the procedure suggested in 'Lesson 16, Listen and sing'.

6. Write

10 minutes

Write.



- Follow the procedure suggested in lesson 15, Write'.

Homework

- Draw a picture of a fish using the letter 'F'.

Lesson 27

Ff

In this lesson, there are six topics to cover:

1. Read (Reading)
2. Look and say (Listening, speaking and reading)
3. Write (Writing)
4. Colour (Reading)
5. Read (Reading)
6. Copy (Writing)

Objectives:

- Read the letters 'a', 'b', 'c', 'd', 'e' and 'f'
- Say the words that have 'f' in initial position.
- Identify the pictures that have 'f' in initial position
- Read the words correctly.
- Trace and write the letters 'F' and 'f'.

Materials:

- Letter cards (a -f)
- Pictures and word cards (flower, fish and flag; highlighting the initial letter 'f'.)

Before you teach:

1. Study the workbook thoroughly.
2. Have the materials ready.

1. Read

5 minutes

Read.

f d e b c

- Show the letter cards one by one and ask the students to read the letter on the card.
- If they can't, read yourself and ask them to follow you.

2. Look and say

15 minutes

Look and say.

Ff



- Follow the procedure suggested in lesson 16, 'Look and say'.

3. Write

10 minutes

- Follow the procedure as suggested in 'Lesson 15, Write'.

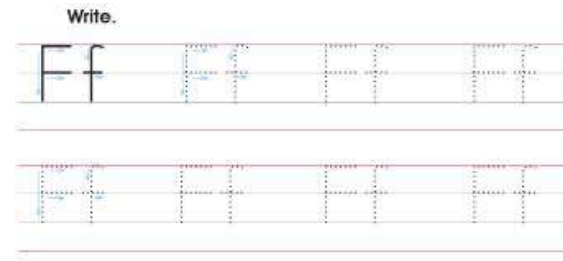

4. Colour the picture that starts with 'f'.

10 minutes

- Follow the procedure suggested in 'Lesson 24, Colour the picture that starts with 'e'.

Colour (the picture that starts with 'f').

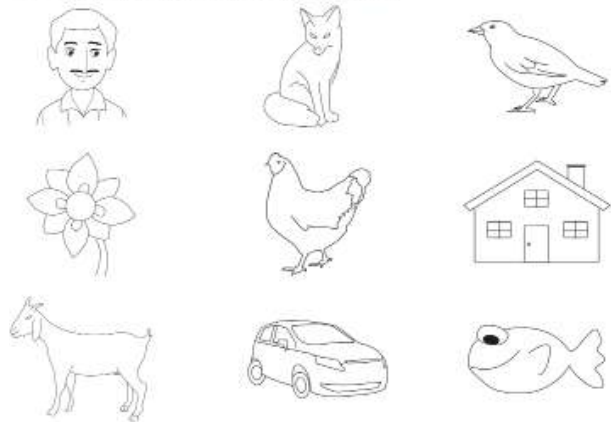

5. Read

10 minutes

- Follow the procedure suggested in 'Lesson 24, Read'.

Read.

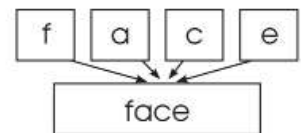
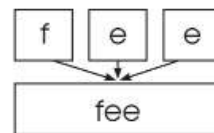

6. Copy

10 minutes

- Follow the procedure as suggested in 'Lesson 16, Copy'.

Copy.

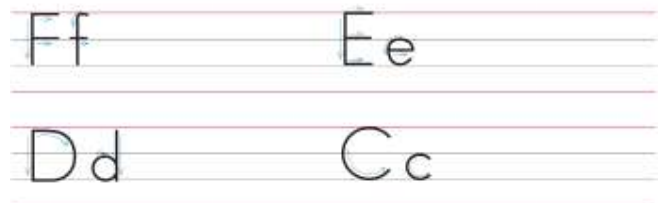

Homework

- Write the letters Aa - Ff.

Lesson 28

Gg

In this lesson, there are six topics to cover:

1. Listen and say (Listening and speaking)
2. Look and discuss (Listening and speaking)
3. Listen and say (Listening, speaking and reading)
4. Colour (Reading)
5. Tick (Reading)
6. Write (Writing)

Objectives:

- Say the words: face, fee, bed and dad orally.
- Say the words that have the letter 'g' in initial position.
- Draw a picture of a giraffe using the letter 'G'.
- Identify the picture having 'g' in initial position.
- Trace over letter 'Gg'.

Materials:

Word cards: face, fee, bed and dad and picture cards: girl, glasses, goat and grapes

Before you teach:

1. Study the workbook thoroughly.
2. Have the materials ready.

1. Listen and say

5 minutes

- Show the word cards one by one and ask the students to read the words.
Listen and say. **face** **fee** **bed** **dad**
- If they can't, read yourself and ask them to follow you.

2. Look and discuss

5 minutes

- Follow the procedure suggested in 'Lesson 15, Look and discuss'.

Look and discuss.



3. Listen and say

15 minutes

Listen and say.



- Follow the procedure suggested in 'Lesson 15, Listen and say'.

4. Colour

15 minutes

Colour.

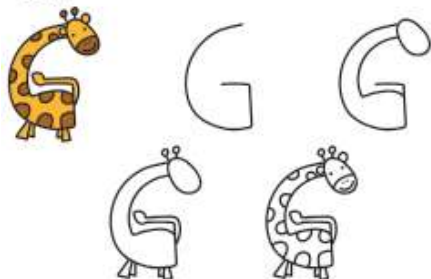

- Follow the procedure suggested in 'Lesson 15, Colour'.

5. Tick the pictures that begin with the letter 'g'

10 minutes

1. Ask the students to name the pictures. Point one picture at a time and ask them to name. **Tick** (the pictures that begin with the letter **g**).
2. Speak out the word for a picture. Elicit from the students asking 'Which picture has 'g'?'
3. When the students have recognized the pictures that have the names with the letter 'g' in initial position, ask them to tick in the box closest to the picture.
4. Ask them to do individually.

6. Write

10 minutes

- Follow the procedure as suggested in 'Lesson 15, Write'.

Write.

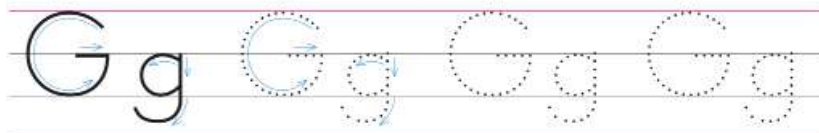

Homework

Draw a picture of a giraffe using the letter 'G'.

Lesson 29

Gg

In this lesson, there are six topics to cover:

1. Read (Reading)
2. Look and say (Listening, speaking and reading)
3. Write (Writing)
4. Colour (Reading)
5. Read (Reading)
6. Copy (Writing)

Objectives:

- Read the letters 'a', 'b', 'c', 'd', 'e', 'f' and 'g'.
- Say the words that have 'g' in initial position.
- Recognise the letter 'g'.
- Read the words correctly.
- Trace and write the letters 'G' and 'g'.

Materials:

- Letter cards (a -g)
- Pictures and word cards (glass, goat and grapes; highlighting the initial letter 'g'.)

Before you teach:

1. Study the workbook thoroughly.
2. Have the materials ready.

1. Read

5 minutes

Read.

g d f e c

- Show the letter cards one by one and ask the students to read the letter on the card.
- If they can't, read yourself and ask them to follow you.

2. Look and say

15 minutes

Look and say.

Gg

glass



goat



grapes



- Follow the procedure suggested in 'Lesson 16, Look and say'.

3. Write

10 minutes

- Follow the procedure as suggested in 'Lesson 15, Write'.

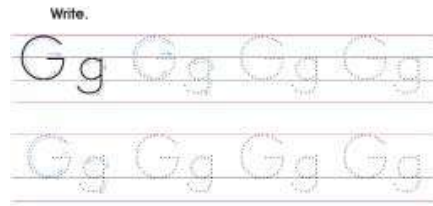

4. Colour g

10 minutes

1. Ask the students to find out the letter 'g'.
2. Ask them to join all gs tracing over the dotted line.
3. Ask them to colour the picture.
4. Move around the class and assist them.

Colour g.

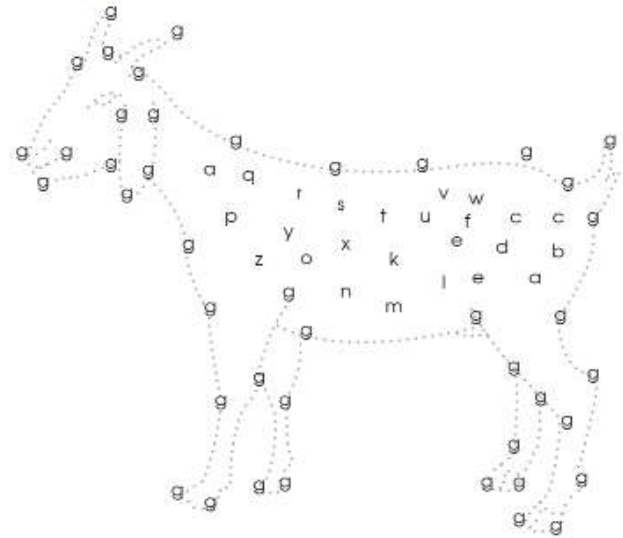

5. Read

10 minutes

- Follow the procedure suggested in 'Lesson 24, Read'.

Read.

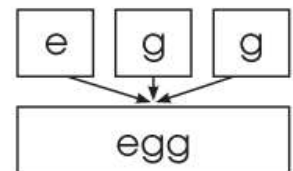
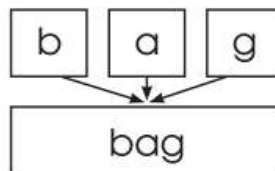

6. Copy

10 minutes

- Follow the procedure as suggested in 'Lesson 16, Copy'.

Copy.

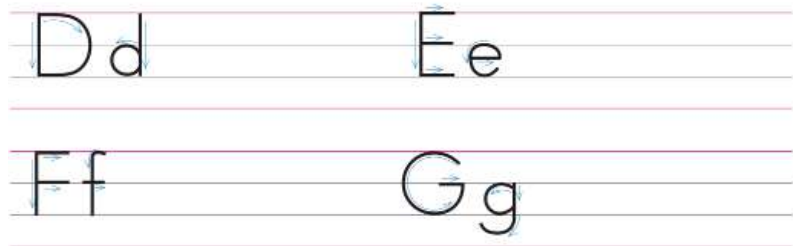

Homework

- Write the letters Aa - Gg.

Lesson 30

Hh

In this lesson, there are six topics to cover:

1. Listen and say (Listening and speaking)
2. Look and discuss (Listening and speaking)
3. Listen and say (Listening, speaking and reading)
4. Colour (Reading)
5. Match (Reading)
6. Write (Writing)

Objectives:

- Say the words: bag, egg, bed and bee orally.
- Say the words that have the letter 'h' in initial position.
- Draw a picture of a horse using the letter 'h'.
- Match capital letters with small letters.
- Trace over letter 'Hh'.

Materials:

Word cards: bag, egg, bed and bee, and picture cards: bag, egg, bed and bee.

Before you teach:

1. Study the workbook thoroughly.
2. Have the materials ready.

1. Listen and say

5 minutes

- Show the word cards one by one and ask the students to read the words.
- If they can't, read yourself and ask them to follow you.

Listen and say.

bag egg bed bee

2. Look and discuss

5 minutes

- Follow the procedure suggested in "Lesson 15, Look and discuss".

Look and discuss.



3. Listen and say

15 minutes

Listen and say.



- Follow the procedure suggested in 'Lesson 15, Listen and say'.

4. Colour

15 minutes

Colour.

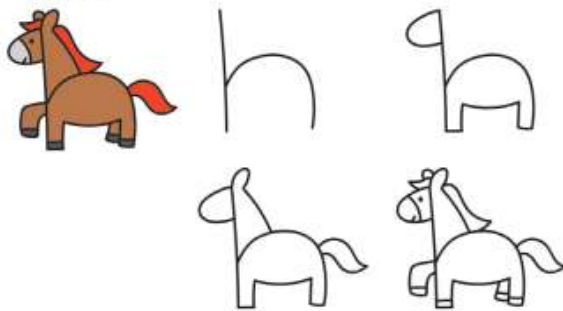

- Follow the procedure suggested in 'Lesson 15, Colour'.

5. Match

10 minutes

Match (the letters).

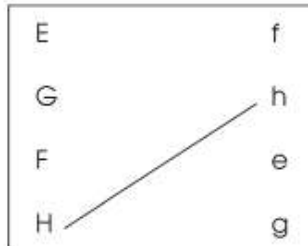
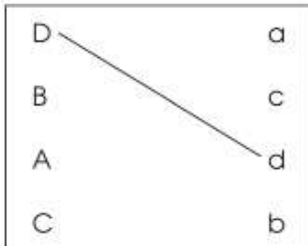

- Ask the students to recognize the alphabets.
- Point at each upper case letter at a time, and ask them to name it.
- Then, ask them to name the lower case letters in turn.

- When they have recognized the letters correctly, ask them to draw lines to join the corresponding letters.

6. Write

10 minutes

Write.

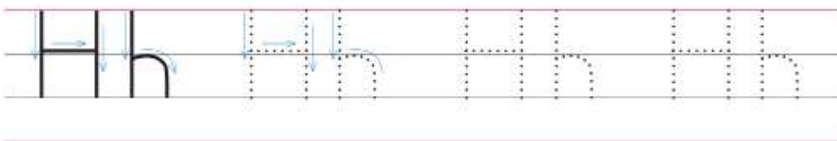

- Follow the procedure as suggested in 'Lesson 15, Write'.

Homework

Draw a picture of a horse using the letter 'h'.

Lesson 31

Hh

In this lesson, there are six topics to cover:

1. Read (Reading)
2. Look and say (Listening, speaking and reading)
3. Write (Writing)
4. Colour (Reading)
5. Read (Reading)
6. Copy (Writing)

Objectives:

- Read the letters: a, b, c, d, e, f, g and h.
- Say the words that have 'h' in initial position.
- Recognise 'H' and 'h'.
- Read the words correctly.
- Trace and write the letters 'H' and 'h'.

Materials:

- Letter cards (a -h)
- Pictures and word cards (house, horse and hand; highlighting the initial letter 'h'.)

Before you teach:

1. Study the workbook thoroughly.
2. Have the materials ready.

1. Read

5 minutes

Read.

g d f h e

- Show the letter cards one by one and ask the students to read the letter on the card.
- If they can't, read yourself and ask them to follow you.

2. Look and say

15 minutes

Look and say.

Hh

house



horse



hand



- Follow the procedure suggested in 'Lesson 16, Look and say'.

3. Write

10 minutes

- Follow the procedure as suggested in 'Lesson 15, Write'.

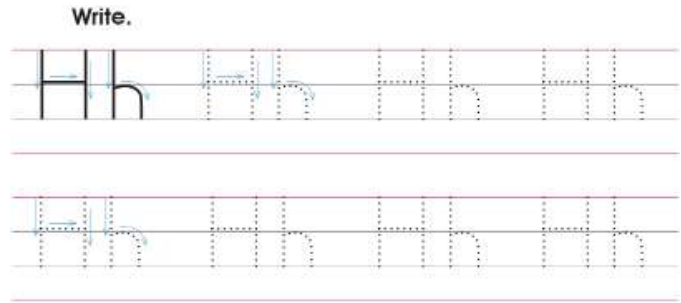

4. Colour the box where there is letter H or h. 10 minutes

- Follow the procedure as suggested in 'Lesson 21, Colour the boxes having 'd' or 'D'.

Colour (the box where there is letter **H** and **h**).

B	h	c	d	H	A
a	H	e	F	h	B
G	H	h	h	H	C
B	h	g	B	h	E
c	H	D	b	H	F

5. Read

10 minutes

- Follow the procedure suggested in 'Lesson 24, Read'.

Read.

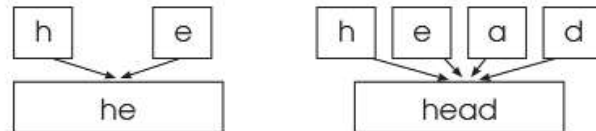

ghee

6. Copy

10 minutes

- Follow the procedure as suggested in 'Lesson 16, Copy'.

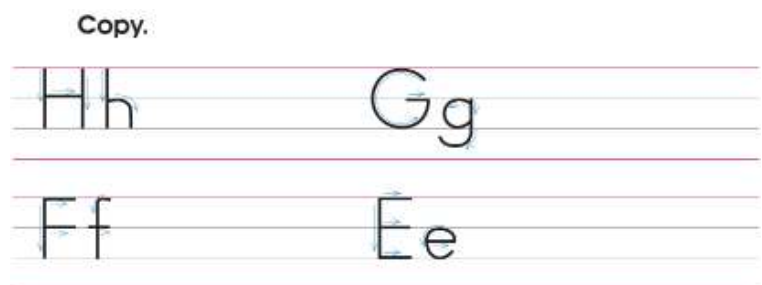

Homework

- Write the letters Aa - Hh.

Lesson 32

Ii

In this lesson, there are six topics to cover:

1. Listen and say (Listening and speaking)
2. Look and discuss (Listening and speaking)
3. Listen and say (Listening, speaking and reading)
4. Colour (Reading)
5. Colour (Reading)
6. Write (Writing)

Objectives:

- Say the words: head, he, ghee orally.
- Say the words that have the letter 'i' in initial position.
- Draw a picture of an ice-cream using the letter 'I'.
- Identify the picture having 'i' in initial position.
- Trace over letter 'Ii'.

Materials:

Word cards: head, he and ghee, and picture cards: ice-cream, iron, ice and inkpot

Before you teach:

1. Study the workbook thoroughly.
2. Have the materials ready.

1. Listen and say 5 minutes

- Show the word cards one by one and ask the students to read the words.
- If they can't, read yourself and ask them to follow you.

Listen and say.

head **he** **ghee**

2. Look and discuss 5 minutes

- Follow the procedure suggested in 'Lesson 15, Look and discuss'.

Look and discuss.



3. Listen and say

15 minutes

Listen and say.



- Follow the procedure suggested in 'Lesson 15, Listen and say'.

4. Colour

15 minutes

Colour.

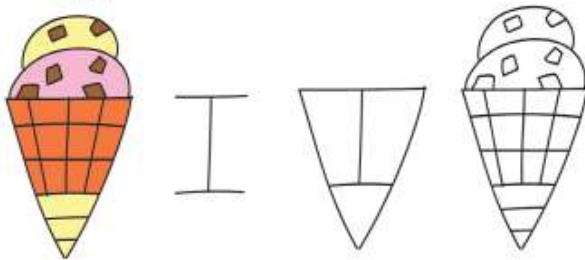

- Follow the procedure suggested in 'Lesson 15, Colour'.

5. Colour the picture that starts with I or i

10 minutes

Colour (the picture that starts with I or i).



- Follow the procedure suggested in 'Lesson 24, Colour the picture that starts with 'e'.

6. Write

10 minutes

Write.



- Follow the procedure as suggested in 'Lesson 15, Write'.

Homework

Draw a picture of an ice-cream using the letter I.

Lesson 33

Ii

In this lesson, there are six topics to cover:

1. Read (Reading)
2. Look and say (Listening, speaking and reading)
3. Write (Writing)
4. Colour (Reading)
5. Read (Reading)
6. Copy (Writing)

Objectives:

- Read the letters: a, b, c, d, e, f, g, h and i.
- Say the words that have 'i' in initial position.
- Recognise 'I' and 'i'.
- Read the words correctly.
- Trace and write the letters 'I' and 'i'.

Materials:

- Letter cards (a -i)
- Pictures and word cards (ice cream, ink and iron; highlighting the initial letter 'i'.)

Before you teach:

1. Study the workbook thoroughly.
2. Have the materials ready.

1. Read

5 minutes

Read.

h e f g i

- Show the letter cards one by one and ask the students to read the letter on the card.
- If they can't, read yourself and ask them to follow you.

2. Look and say

15 minutes

Look and say.

Ii



- Follow the procedure suggested in 'Lesson 16, Look and say'.

3. Write

10 minutes

- Follow the procedure as suggested in 'Lesson 15, Write'.

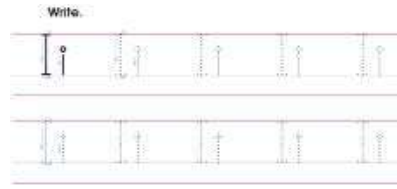

4. Colour I or i.

10 minutes

- Follow the procedure as suggested in 'Lesson 21, Colour the boxes having 'd' or 'D'.

Colour I and i.

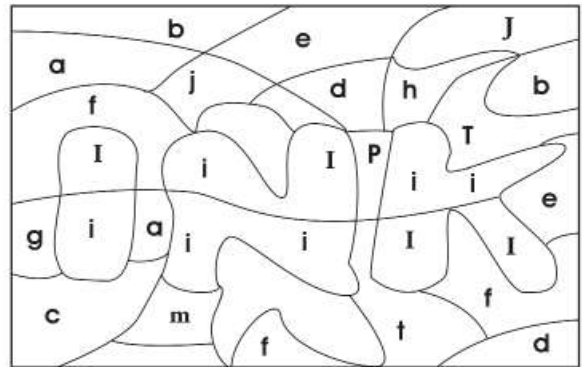

5. Read

10 minutes

- Follow the procedure suggested in 'Lesson 24, Read'.

Read.

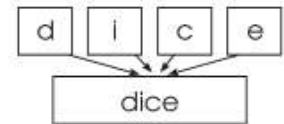
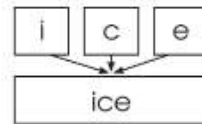

big

dig

child

6. Copy

10 minutes

- Follow the procedure as suggested in lesson 16, 'Copy'.

Copy.

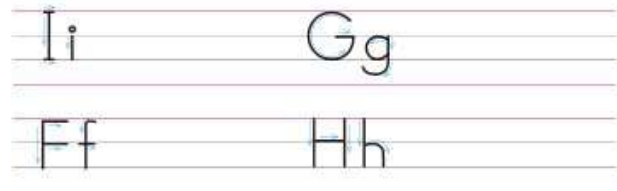

Homework

- Write the letters Aa - Ii.

Lesson 34

Jj

In this lesson, there are six topics to cover:

1. Listen and say (Listening and speaking)
2. Look and discuss (Listening and speaking)
3. Listen and say (Listening, speaking and reading)
4. Colour (Reading)
5. Listen and say (Listening and speaking)
6. Write (Writing)

Objectives:

- Say the words: big, dig, ice and dice orally.
- Say the words that have the letter 'j' in initial position.
- Draw a picture of a jug using the letter 'J'.
- Sing and enjoy the rhyme.
- Trace over letter 'Jj'.

Materials:

Word cards: big, dig, ice and dice, and picture cards: jug, joker, jar and jungle

Before you teach:

1. Study the workbook thoroughly.
2. Have the materials ready.

1. Listen and say

5 minutes

- Show the word cards one by one and ask the students to read the words.
- If they can't, read yourself and ask them to follow you.

Listen and say.

big

dig

ice

dice

2. Look and discuss

5 minutes

Look and discuss.



- Follow the procedure suggested in 'Lesson 15, Look and discuss'.

3. Listen and say

15 minutes

Listen and say.



J



- Follow the procedure suggested in 'Lesson 15, Listen and say'.

4. Colour

15 minutes

Colour.

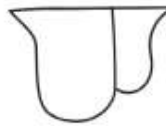

- Follow the procedure suggested in lesson 15, 'Colour'.

5. Listen and say

10 minutes

Listen and say.

Jay and Junu, Jaya and Junu,
Jumped the rope, jumped the rope,
Jumped all day.
Jaya and Junu, Jaya and Junu,
Ate the jam, ate the jam,
Ate all day.



- Follow the procedure suggested in 'Lesson 16, Listen and sing'.

6. Write

10 minutes

Write.



- Follow the procedure as suggested in 'Lesson 15, Write'.

Homework

- Draw a picture of a jug using the letter J.

Lesson 35

Jj

In this lesson, there are six topics to cover:

1. Read (Reading)
2. Look and say (Listening, speaking and reading)
3. Write (Writing)
4. Match (Reading)
5. Read (Reading)
6. Copy (Writing)

Objectives:

- Read the letters: a, b, c, d, e, f, g, h, i and j.
- Say the words that have 'j' in initial position.
- Recognise 'J' and 'j'.
- Read the words correctly.
- Trace and write the letters 'J' and 'j'.

Materials:

- Letter cards (a -j)
- Pictures and word cards (jug, joker and jam; highlighting the initial letter 'j'.)

Before you teach:

1. Study the workbook thoroughly.
2. Have the materials ready.

1. Read 5 minutes

Read.

h j f i g

- Show the letter cards one by one and ask the students to read the letter on the card.
- If they can't, read yourself and ask them to follow you.

2. Look and say 15 minutes

Look and say.

Jj



- Follow the procedure suggested in 'Lesson 16, Look and say'.

3. Write

10 minutes

- Follow the procedure as suggested in 'Lesson 15, Write'.

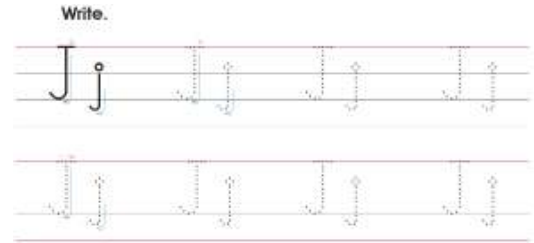

4. Match.

10 minutes

1. Ask the students what they can see in the picture.
2. Ask them to name all the things in the picture in English.
3. After this, ask the student to look at the pictures kept around the main picture.
4. Ask them to name it. Then ask them to match this picture with the same picture in the main picture.
5. Move around the class and help them.

Match.



5. Read

10 minutes

- Follow the procedure suggested in 'Lesson 24, Read'.

Read.

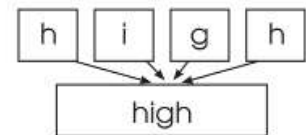
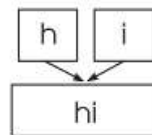

6. Copy

10 minutes

- Follow the procedure as suggested in 'Lesson 16, Copy'.

Copy.



Homework

- Write the letters Aa - Jj.

Lesson 36

Ff - Jj

In this lesson, there are four topics to cover:

1. Listen and say (Listening, speaking and reading)
2. Look and write (Writing)
3. Recognise letters 'F', 'G', 'H', I and J (Reading)
4. Write (Writing)

Objectives:

- Blend consonant and vowel.
- Blend onset with rime.
- Discriminate sounds.
- Write words.

Materials:

- Alphabet cards (a-j)

Before you teach:

- Study the workbook thoroughly.
- Have the materials ready.

1. Listen and say

30 minutes

- Show the letter card of the letter 'f' and keep it with the cards 'a', 'e' and 'i' respectively.

Listen and say.

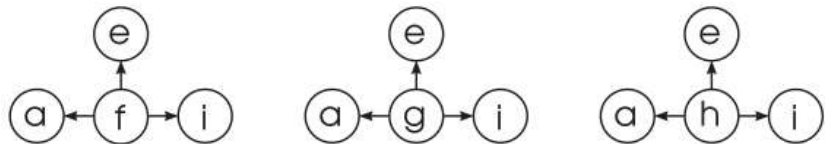

- Then read yourself combining them, e.g. f+a =/fa/ and ask the students to follow you.
- Now combine other consonant letters with these vowel sounds in the similar way and ask the students to pronounce them.
- If they can't read provide a model pronunciation and ask the students to follow you.

2. Look and write

10 minutes

- Ask the students to look at the pictures and name them.
- Help them if they can't.
- Once they learn the name, ask them: What is the first letter?
- Tell them that, they have to fill the initial letter in each blank space.

- Move around the class and help them while they are doing the task.
- After they complete, check it thoroughly.

Look and write.



3. Find and colour the boxes having F, G, H, I and J. 10 minutes

Find and colour the boxes having F, G, H, I and J.

C	P	J	H	C
B	A	G	E	A
I	L	B	A	H
A	C	M	D	Z
V	B	E	F	G

- Follow the procedure as suggested in Lesson 21, Colour the boxes having 'd' or 'D'.

4. Write 10 minutes

- Conduct this as an individual work.
- Ask the students to copy the words in the row just below.
- Write yourself and show them how they should write.
- Move around the class and assist them.
- Once they complete the task, check it thoroughly.

Write.

fee bag head

ice hi high

Homework

- Write the letters Aa - Jj.

Lesson 37

Kk

In this lesson, there are six topics to cover:

1. Listen and say (Listening and speaking)
2. Look and discuss (Listening and speaking)
3. Listen and say (Listening, speaking and reading)
4. Colour (Reading)
5. Find (K and k) and colour the boxes
6. Write (Writing)

Objectives:

- Say the words: hi, high, ice and ghee orally.
- Say the words that have the letter 'k' in initial position.
- Draw a picture of a key using the letter 'K'.
- Recognise K and k
- Trace over letter 'Kk'.

Materials:

Word cards: hi, high, ice and ghee, and picture cards: key, king, kite and kettle

Before you teach:

1. Study the workbook thoroughly.
2. Have the materials ready.

1. Listen and say 5 minutes

Listen and say.

hi high ice ghee

- Show the word cards one by one and ask the students to read the words.
- If they can't, read yourself and ask them to follow you.

2. Look and discuss 5 minutes

Look and discuss.



- Follow the procedure suggested in 'Lesson 15, Look and discuss'.

3. Listen and say

15 minutes

- Follow the procedure suggested in 'Lesson 15, 'Listen and say'.

Listen and say.



k



4. Colour

15 minutes

- Follow the procedure suggested in lesson 15, 'Colour'.

Colour.



K



5. Find (K and k) and the colour the boxes.

10 minutes

- Follow the procedure as suggested in lesson 21, Colour the boxes having 'd' or 'D'.

Find (K and k) and colour the boxes.



a	k	k	k	K	k	k	K	A	C
b	d	L	o	p	r	s	K	F	G
c	d	D	q	a	k	k	K	e	f
e	j	m	s	t	k	i	h	g	u
g	a	b	d	c	k	j	x	w	v
k	k	k	k	k	k	a	b	y	r
k	r	s	m	n	z	x	w	v	m
k	w	v	u	t	y	a	b	t	u
k	k	k	k	k	k	k	k	k	k
c	d	e	o	n	m	y	x	w	z



6. Write

10 minutes

- Follow the procedure as suggested in lesson 15, 'Write'.

Write.



Homework

- Draw a picture of a key using the letter K.

Lesson 38

Kk

In this lesson, there are six topics to cover:

1. Read (Reading)
2. Look and say (Listening, speaking and reading)
3. Write (Writing)
4. Match (Reading)
5. Read (Reading)
6. Copy (Writing)

Objectives:

- Read the letters: a, b, c, d, e, f, g, h, i, j and k.
- Say the words that have 'k' in initial position.
- Identify the pictures that have letter 'k' in the initial position.
- Read the words correctly.
- Trace and write the letters 'K' and 'k'.

Materials:

- Letter cards (a -k)
- Pictures and word cards (kite, key and kettle; highlighting the initial letter 'k'.)

Before you teach:

1. Study the workbook thoroughly.
2. Have the materials ready.

1. Read 5 minutes

- Show the letter cards one by one and ask the students to read the letter on the card. Read.
g j h k i
- If they can't, read yourself and ask them to follow you.

2. Look and say 15 minutes

- Follow the procedure suggested in 'Lesson 16, Look and say'.

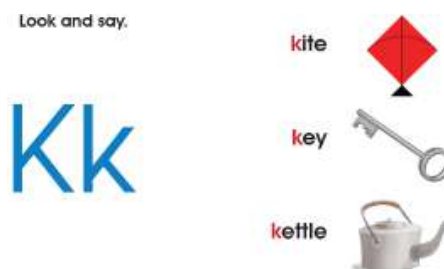

3. Write

10 minutes

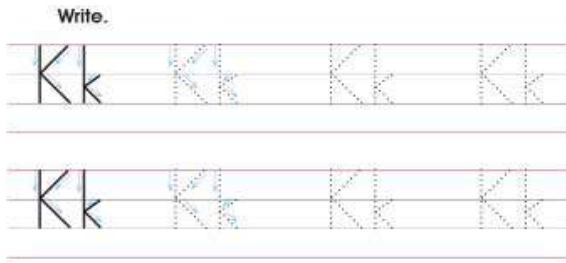

- Follow the procedure as suggested in 'Lesson 15, Write'.

4. Colour the pictures that begin with 'k'

10 minutes

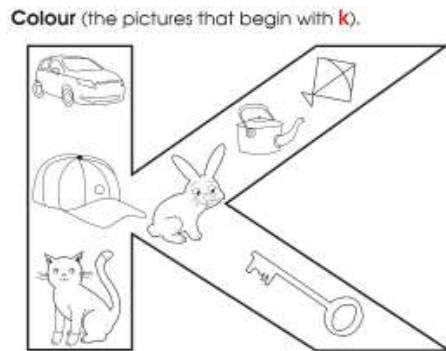

- Follow the procedure suggested in 'Lesson 24, Colour the picture that starts with 'e'.

5. Read

10 minutes

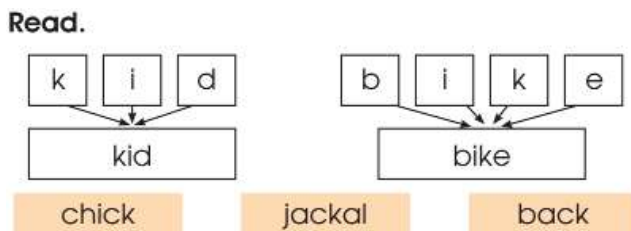

- Follow the procedure suggested in 'Lesson 24, Read'.

6. Copy

10 minutes

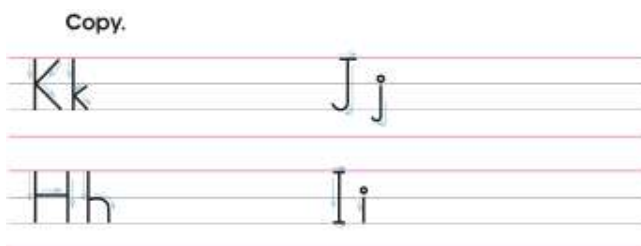

- Follow the procedure as suggested in 'Lesson 16, Copy'.

Homework

- Write the letters Aa - Kk.

Lesson 39

Ll

In this lesson, there are six topics to cover:

1. Listen and say (Listening and speaking)
2. Look and discuss (Listening and speaking)
3. Listen and say (Listening, speaking and reading)
4. Colour (Reading)
5. Colour
6. Write (Writing)

Objectives:

- Say the words: bike, kid, beak and jackal orally.
- Say the words that have the letter 'l' in initial position.
- Draw a picture of a lamp using the letter 'L'.
- Recognise L and l
- Trace over letter 'Ll'.

Materials:

Word cards: bike, kid, beak and jackal, and picture cards: leg, leaf, lion and lamp

Before you teach:

1. Study the workbook thoroughly.
2. Have the materials ready.

1. Listen and say

5 minutes

Listen and say.

bike kid beak jackal

- Show the word cards one by one and ask the students to read the words.
- If they can't, read yourself and ask them to follow you.

2. Look and discuss

5 minutes

Look and discuss.



- Follow the procedure suggested in 'Lesson 15, Look and discuss'.

3. Listen and say

15 minutes

- Follow the procedure suggested in 'Lesson 15, Listen and say'.

Listen and say.



4. Colour

15 minutes

- Follow the procedure suggested in 'Lesson 15, Colour'.

Colour.

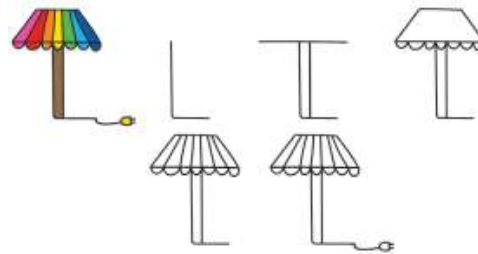

5. Colour the boxes L red and I blue

10 minutes

- Follow the procedure as suggested in 'Lesson 21, Colour the boxes having 'd' or 'D'.
- Do not forget to tell the students to colour the boxes with 'L' in red and 'l' in blue.

Colour the boxes: L red and l blue.

l	L	l	l	l
l	L	l	l	l
l	L	l	l	l
l	L	l	l	l
l	L	L	L	L

6. Write

10 minutes

- Follow the procedure as suggested in 'Lesson 15, Write'.

Write.



Homework

- Draw a picture of a lamp using the letter L.

Lesson 40

Ll

In this lesson, there are six topics to cover:

1. Read (Reading)
2. Look and say (Listening, speaking and reading)
3. Write (Writing)
4. Colour (Reading)
5. Read (Reading)
6. Copy (Writing)

Objectives:

- Read the letters: a, b, c, d, e, f, g, h, i, j, k and l
- Say the words that have 'l' in initial position.
- Identify the pictures that have letter 'l' in the initial position.
- Read the words correctly.
- Trace and write the letters 'L' and 'l'.

Materials:

- Letter cards (a -l)
- Pictures and word cards (lamp, leaf and lion; highlighting the initial letter 'k'.)

Before you teach:

1. Study the workbook thoroughly.
2. Have the materials ready.

1. Read 5 minutes

- Show the letter cards one by one and ask the students to read the letter on the card.
- If they can't, read yourself and ask them to follow you.

Read.

l j i k h

2. Look and say 15 minutes

- Follow the procedure suggested in 'Lesson 16, Look and say'.

Look and say.

L l

lamp



leaf



lion



3. Write

10 minutes



- Follow the procedure as suggested in 'Lesson 15, Write'.

4. Colour the pictures that begin with 'l'.

10 minutes

Colour (the pictures that begin with l).

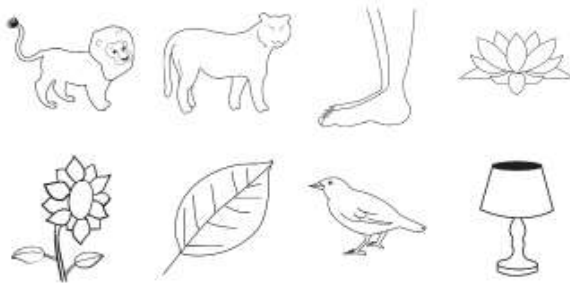

- Follow the procedure suggested in 'Lesson 24, Colour the picture that starts with 'e'.

5. Read

10 minutes

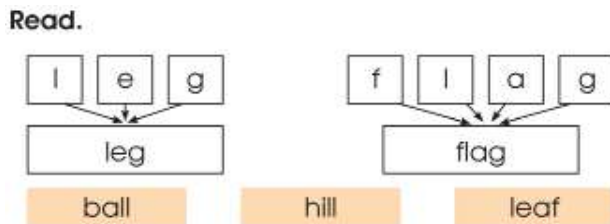

- Follow the procedure suggested in 'Lesson 24, Read'.

6. Copy

10 minutes

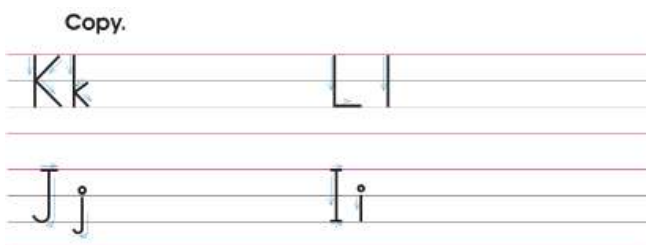

- Follow the procedure as suggested in 'Lesson 16, Copy'.

Homework

- Write the letters Aa - Ll.

Lesson 41

Mm

In this lesson, there are six topics to cover:

1. Listen and say (Listening and speaking)
2. Look and discuss (Listening and speaking)
3. Listen and say (Listening, speaking and reading)
4. Colour (Reading)
5. Listen and say (Rhyme)
6. Write (Writing)

Objectives:

- Say the words: ball, flag, leg and leaf orally.
- Say the words that have the letter 'm' in initial position.
- Draw a picture of a lamp using the letter 'M'.
- Sing and enjoy the rhyme.
- Trace over letter 'Mm'.

Materials:

Word cards: ball, flag, leg and leaf, and picture cards: man, monkey, moon, mango

Before you teach:

1. Study the workbook thoroughly.
2. Have the materials ready.

1. Listen and say

5 minutes

Listen and say.

ball flag leg leaf

- Show the word cards one by one and ask the students to read the words.
- If they can't, read yourself and ask them to follow you.

2. Look and discuss

5 minutes

Look and discuss.



- Follow the procedure suggested in 'Lesson 15, Look and discuss'.

3. Listen and say

15 minutes

- Follow the procedure suggested in 'Lesson 15, Listen and say'.

Listen and say.



m



4. Colour

15 minutes

- Follow the procedure suggested in 'Lesson 15, Colour'.

Colour.



5. Listen and say

10 minutes

- Follow the procedure suggested in 'Lesson 16, Listen and sing'.

Listen and say.

Monkey, monkey m - m - m

Monkey, monkey,
standing on the moon

Monkey, monkey,
come home soon,



6. Write

10 minutes

- Follow the procedure as suggested in 'Lesson 15, Write'.

Write.



Homework

- Draw a picture of a mouse using the letter M.

Lesson 42

Mm

In this lesson, there are six topics to cover:

1. Read (Reading)
2. Look and say (Listening, speaking and reading)
3. Write (Writing)
4. Colour (Reading)
5. Read (Reading)
6. Copy (Writing)

Objectives:

- Read the letters: a, b, c, d, e, f, g, h, i, j, k, l and m.
- Say the words that have 'm' in initial position.
- Recognise M and m.
- Read the words correctly.
- Trace and write the letters 'M' and 'm'.

Materials:

- Letter cards (a -m)
- Pictures and word cards (man, monkey and mango; highlighting the initial letter 'm'.)

Before you teach:

1. Study the workbook thoroughly.
2. Have the materials ready.

1. Read

5 minutes

- Show the letter cards one by one and ask **Read.** the students to read the letter on the card. **m j k i l**
- If they can't, read yourself and ask them to follow you.

2. Look and say

15 minutes

- Follow the procedure suggested in 'Lesson 16, Look and say'.



3. Write

10 minutes

Write.



- Follow the procedure as suggested in 'Lesson 15, Write'.

4. Colour (M with green and m with red)

10 minutes

Colour (M with green and m with red).

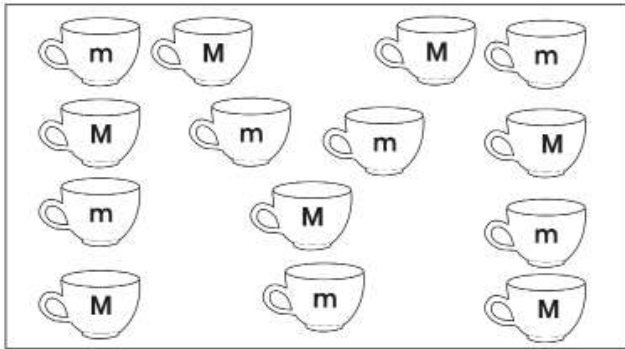

1. Ask the students to recognize the capital M and small m.
2. Then tell them to colour the cup with capital 'M' in green and the small 'm' in red.
3. Ask the students to do the task individually.

5. Read

10 minutes

Read.

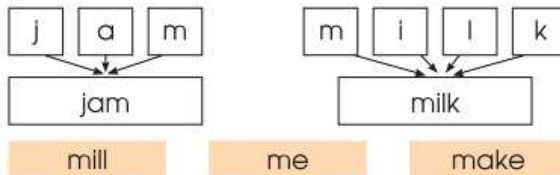

- Follow the procedure suggested in 'Lesson 24, Read'.

6. Copy

10 minutes

Copy.

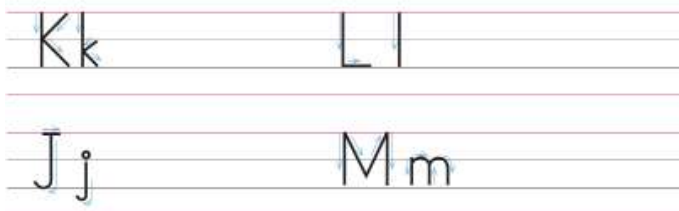

- Follow the procedure as suggested in 'Lesson 16, Copy'.

Homework

- Write the letters Aa - Mm.

Lesson 43

Nn

In this lesson, there are six topics to cover:

1. Listen and say (Listening and speaking)
2. Look and discuss (Listening and speaking)
3. Listen and say (Listening, speaking and reading)
4. Colour (Reading)
5. Find and trace (Reading)
6. Write (Writing)

Objectives:

- Say the words: milk, jam, mill and make orally.
- Say the words that have the letter 'n' in initial position.
- Draw a picture of a net using the letter 'N'.
- Recognise the letter N.
- Trace over letter 'Nn'.

Materials:

Word cards: milk, jam, mill and make, and picture cards: nose, nest, net and 9.

Before you teach:

1. Study the workbook thoroughly.
2. Have the materials ready.

1. Listen and say

5 minutes

Listen and say.

milk jam mill make

- Show the word cards one by one and ask the students to read the words.
- If they can't, read yourself and ask them to follow you.

2. Look and discuss

5 minutes

- Follow the procedure suggested in 'Lesson 15, Look and discuss'.

Look and discuss.



3. Listen and say

15 minutes

- Follow the procedure suggested in 'Lesson 15, Listen and say'.

Listen and say.



4. Colour

15 minutes

- Follow the procedure suggested in 'Lesson 15, Colour'.

Colour.

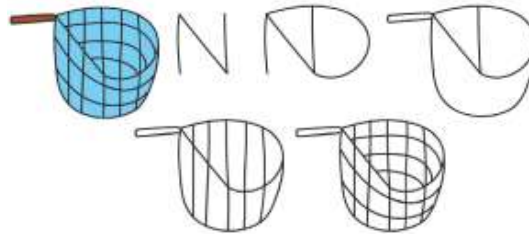

5. Find and trace the way

10 minutes

- Do this task individually.
- Ask the students to see where the eagle is and where its nest is.
- Tell them that they have to follow letter 'e' to reach to the nest.
- Ask them to begin as indicated by the arrow.
- Move around the class and help them.

Find and trace (the way).

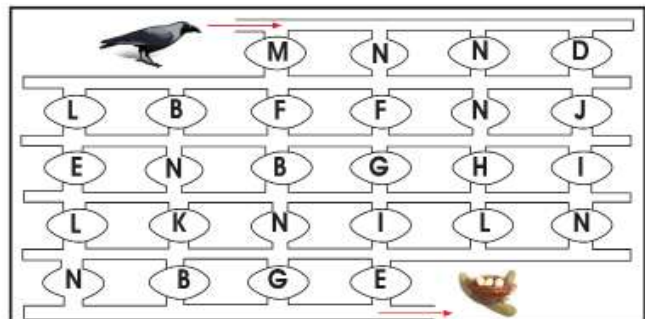

6. Write

10 minutes

- Follow the procedure as suggested in 'Lesson 15, Write'.

Write.



Homework

- Draw a picture of a net using the letter N.

Lesson 44

Nn

In this lesson, there are six topics to cover:

1. Read (Reading)
2. Look and say (Listening, speaking and reading)
3. Write (Writing)
4. Colour (Reading)
5. Read (Reading)
6. Copy (Writing)

Objectives:

- Read the letters: a, b, c, d, e, f, g, h, i, j, k, l, m and n.
- Say the words that have 'n' in initial position.
- Recognise the pictures that have 'm' in the initial position of their names.
- Read the words correctly.
- Trace and write the letters 'N' and 'n'.

Materials:

- Letter cards (a -n)
- Pictures and word cards (nose, nest, nurse; highlighting the initial letter 'n'.)

Before you teach:

1. Study the workbook thoroughly.
2. Have the materials ready.

1. Read 5 minutes

- Show the letter cards one by one and ask the students to read the letter on the card. Read.
n j k m l
- If they can't, read yourself and ask them to follow you.

2. Look and say 15 minutes

- Follow the procedure suggested in 'Lesson 16, Look and say'.

Look and say.

Nn

nose



nest



nurse



3. Write

10 minutes

Write.

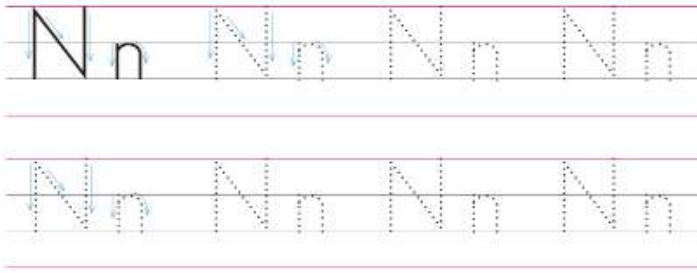

- Follow the procedure as suggested in 'Lesson 15, Write'.

4. Colour the picture that begins with n.

10 minutes

Colour (the picture that begins with n).

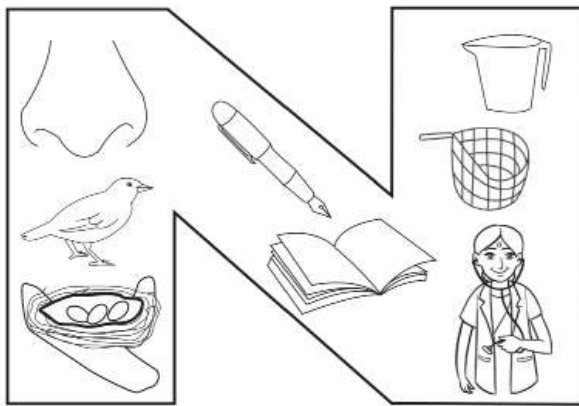

- Follow the procedure suggested in 'Lesson 24, Colour the picture that starts with 'e'.

5. Read

10 minutes

Read.

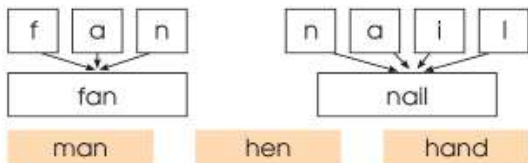

- Follow the procedure suggested in 'Lesson 24, Read'.

6. Copy

10 minutes

Copy.

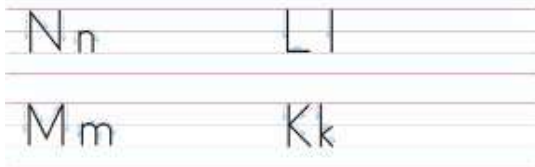

- Follow the procedure as suggested in 'Lesson 16, Copy'.

Homework

- Write the letters Aa - Nn.

Lesson 45

Oo

In this lesson, there are six topics to cover:

1. Listen and say (Listening and speaking)
2. Look and discuss (Listening and speaking)
3. Listen and say (Listening, speaking and reading)
4. Colour (Reading)
5. Listen and say (Rhyme)
6. Write (Writing)

Objectives:

- Say the words: man, fan, hen and hand orally.
- Say the words that have the letter 'o' in initial position.
- Draw a picture of a net using the letter 'O'.
- Sing and enjoy a chant.
- Trace over letter 'Oo'.

Materials

Word cards: man, fan, hen and hand, and picture cards: orange, onion, owl and ostrich

Before you teach:

1. Study the workbook thoroughly.
2. Have the materials ready.
3. Learn to sing the rhyme. (<https://www.youtube.com/watch?v=9LbZSyx-7Xo>)

1. Listen and say

5 minutes

Listen and say.

man fan hen hand

- Show the word cards one by one and ask the students to read the words.
- If they can't, read yourself and ask them to follow you.

2. Look and discuss

5 minutes

Look and discuss.



- Follow the procedure suggested in 'Lesson 15, Look and discuss'.

3. Listen and say

15 minutes

- Follow the procedure suggested in 'Lesson 15, Listen and say'.

Listen and say.



4. Colour

15 minutes

- Follow the procedure suggested in 'Lesson 15, Colour'.

Colour.

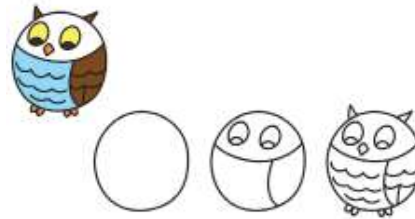

5. Listen and say

10 minutes

- Follow the procedure suggested in lesson 16, 'Listen and sing'.

Listen and say.



6. Write

10 minutes

- Follow the procedure as suggested in 'Lesson 15, Write'.

Write.

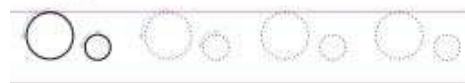

Homework

- Draw a picture of an owl using the letter O.

Lesson 46

Oo

In this lesson, there are six topics to cover:

1. Read (Reading)
2. Look and say (Listening, speaking and reading)
3. Write (Writing)
4. Colour letter O (Reading)
5. Read (Reading)
6. Copy (Writing)

Objectives:

- Read the letters: a, b, c, d, e, f, g, h, i, j, k, l, m, n and o.
- Say the words that have 'o' in initial position.
- Recognise the letter 'o'.
- Read the words correctly.
- Trace and write the letters 'O' and 'o'.

Materials:

- Letter cards (a -o)
- Pictures and word cards (orange, onion and owl; highlighting the initial letter 'o'.)

Before you teach:

1. Study the workbook thoroughly.
2. Have the materials ready.

1. Read 5 minutes

- Show the letter cards one by one and ask the students to read the letter on the card.
- If they can't, read yourself and ask them to follow you.

Read.
o n m l k

2. Look and say 15 minutes

- Follow the procedure suggested in 'Lesson 16, Look and say'.

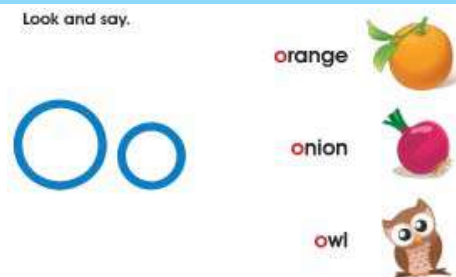

3. Write

10 minutes

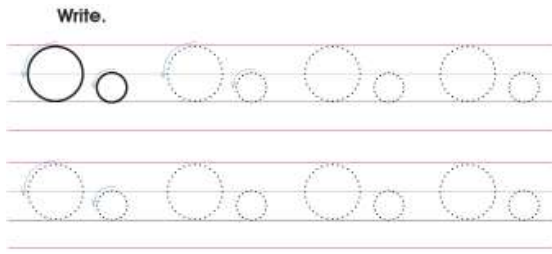

- Follow the procedure as suggested in 'Lesson 15, Write'.

4. Colour letter o

10 minutes

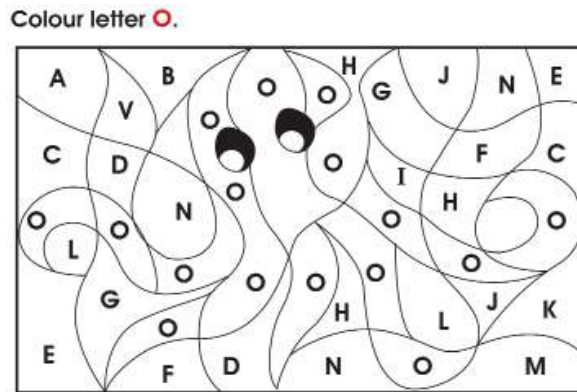

- Follow the procedure as suggested in lesson 21, Colour the boxes having 'd' or 'D'.

5. Read

10 minutes

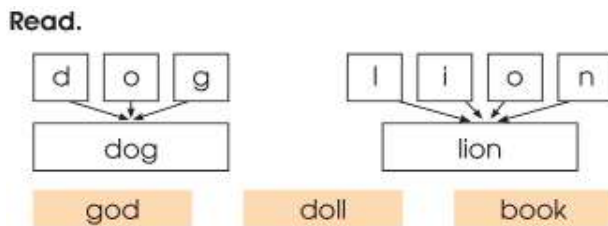

- Follow the procedure suggested in lesson 24, Read.

6. Copy

10 minutes

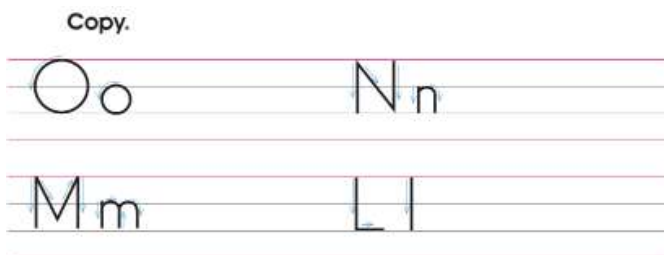

- Follow the procedure as suggested in 'Lesson 16, Copy'.

Homework

- Write the letters Aa - Oo.

Lesson 47

Kk - Oo

In this lesson, there are four topics to cover:

1. Listen and say (Listening, speaking and reading)
2. Match and write (Writing)
3. Find the words (Reading)
4. Write (Writing)

Objectives:

- Blend consonant and vowel.
- Blend onset with rime.
- Identify words
- Write words.

Materials:

- Alphabet cards (a-o)

Before you teach:

1. Study the workbook thoroughly.
2. Have the materials ready.

1. Listen and say 30 minutes



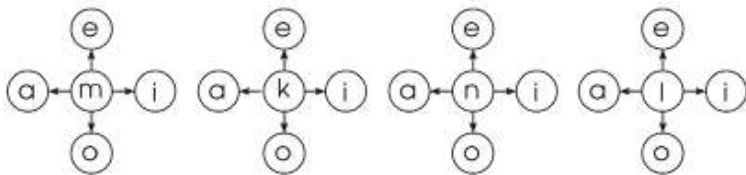





Listen and say.



- Follow the procedure as suggested in 'Lesson 36, Look and say'.

2. Match and write 10 minutes

Match and write.

l		allball.....
l		lag
b		eg
f		am
m		an
d		en
h		og
f		oon

- Ask the students to look at the pictures and name them.
- Help them if they can't.
- Once they learn the name, ask them: What is the first letter?
- Tell them that they have to match the initial letter with the picture.
- Now, ask them to write a word putting the first letter and other letters given

along side of the picture.

- Move around the class and help them while they are doing the task.
- After they complete, check it thoroughly.

3. Find the words

10 minutes

- Ask the students to look at the picture.
- Ask them to name the picture.
- Tell them to find the name of the picture in the spelling.
- Once they find it, ask them to circle the word.

Find the words.

B	D	M	R	S	B	B	O
R	D	L	I	O	N	M	N
P	B	O	O	K	B	A	G
X	L	F	W	F	A	N	G
Y	O	D	Q	L	N	G	Y
P	B	E	A	Z	A	O	S
U	O	N	I	O	N	O	T
M	H	O	F	M	A	G	K



4. Write

10 minutes

- Follow the procedure suggested in 'Lesson 36 , Write correct words'.

Write.

kid leg jam

fan dog book

Homework

- Write the letters Aa - Oo.

Lesson 48

Pp

In this lesson, there are six topics to cover:

1. Listen and say (Listening and speaking)
2. Look and discuss (Listening and speaking)
3. Listen and say (Listening, speaking and reading)
4. Colour (Reading)
5. Match (Reading)
6. Write (Writing)

Objectives:

- Say the words: lion, book, doll and onion orally.
- Say the words that have the letter 'p' in initial position.
- Draw a picture of a penguin using the letter 'P'.
- Trace over letter 'Pp'.

Materials:

Word cards: lion, book, doll and onion, and picture cards: pen, parrot, pan and pin

Before you teach:

1. Study the workbook thoroughly.
2. Have the materials ready.

1. Listen and say

5 minutes

- Show the word cards one by one and **Listen and say.**
ask the students to read the words. **lion book doll onion**
- If they can't, read yourself and ask them to follow you.

2. Look and discuss

5 minutes

- Follow the procedure suggested in lesson 15, 'Look and discuss'.



3. Listen and say

15 minutes

Listen and say.



- Follow the procedure suggested in lesson 15, 'Listen and say'.

4. Colour

15 minutes

Colour.



- Follow the procedure suggested in lesson 15, 'Colour'.

5. Match

10 minutes

Match.



- Follow the procedure suggested in 'Lesson 35, Match'.

6. Write

10 minutes

Write.



- Follow the procedure as suggested in 'Lesson 15, Write'.

Homework

- Draw a picture of a penguin using the letter P.

Lesson 49

Pp

In this lesson, there are six topics to cover:

1. Read (Reading)
2. Look and say (Listening, speaking and reading)
3. Write (Writing)
4. Read (Reading)
5. Read and discuss (Reading)
6. Copy (Writing)

Objectives:

- Read the letters: a, b, c, d, e, f, g, h, i, j, k, l, m, n, o and p.
- Say the words that have 'p' in initial position.
- Recognise the letter 'p'.
- Read the words correctly.
- Read a phrase correctly.
- Trace and write the letters 'P' and 'p'.

Materials:

- Letter cards (a -p)
- Pictures and word cards (orange, onion and owl; highlighting the initial letter 'p'.)

Before you teach:

1. Study the workbook thoroughly.
2. Have the materials ready.

1. Read 5 minutes

- Read.
- p k m o n
- Show the letter cards one by one and ask the students to read the letter on the card.
 - If they can't, read yourself and ask them to follow you.

2. Look and say 15 minutes



- Follow the procedure suggested in 'Lesson 16, Look and say'.

3. Write

10 minutes

- Follow the procedure as suggested in 'Lesson 15, Write'.

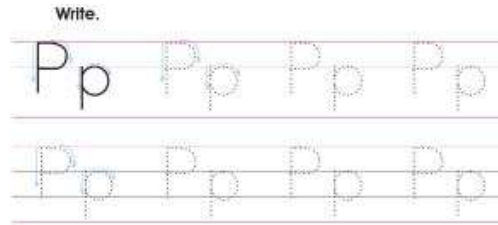

4. Read

10 minutes

- Follow the procedure suggested in 'Lesson 24, Read'.

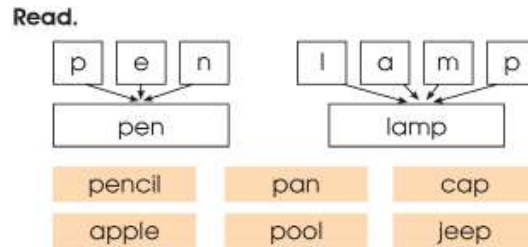

5. Read and discuss

- Ask the students a few questions related to the picture. For example;
 - a. What is this?
 - b. What do you use it for? Etc.
- Write the text on the board. Read it and ask the students to follow you. Repeat it for a couple of times.
- Ask them to read the text individually.
- Move around the class and assist them.

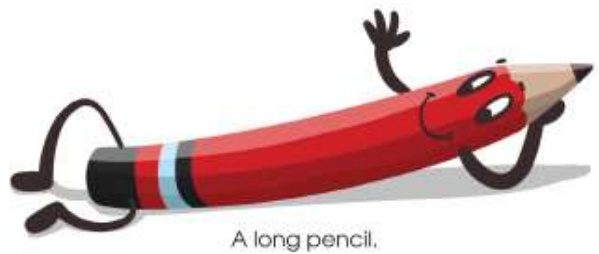

6. Copy

10 minutes

- Follow the procedure as suggested in 'Lesson 16, Copy'.

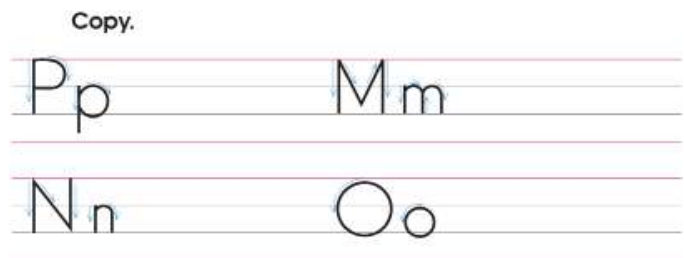

Homework

- Write the letters Aa - Pp.

Lesson 50

Qq

In this lesson, there are six topics to cover:

1. Listen and say (Listening and speaking)
2. Look and discuss (Listening and speaking)
3. Listen and say (Listening, speaking and reading)
4. Colour (Reading)
5. Find and colour (Reading)
6. Write (Writing)

Objectives:

- Say the words: lamp, pen, pencil and jeep orally.
- Say the words that have the letter 'q' in initial position.
- Draw a picture of queen using the letter 'Q'.
- Trace over letter 'Qq'.

Materials:

Word cards: lamp, pen, pencil and jeep, and picture cards: queen, quill, quilt and queue

Before you teach:

- Study the workbook thoroughly.
- Have the materials ready.

1. Listen and say 5 minutes

- Show the word cards one by one and ask the students to read the words.
- If they can't, read yourself and ask them to follow you.

Listen and say.

lamp pen pencil jeep

2. Look and discuss 5 minutes

- Follow the procedure suggested in lesson 15, 'Look and discuss'.

Look and discuss.



3. Listen and say

15 minutes

Listen and say.



- Follow the procedure suggested in 'Lesson 15, Listen and say'.

4. Colour

15 minutes

Colour.

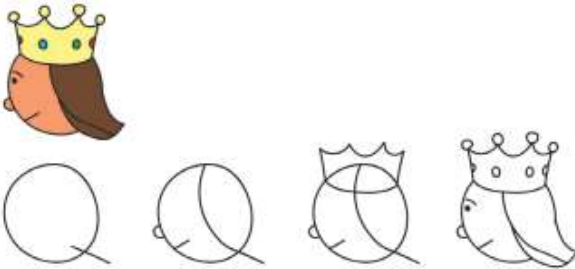

- Follow the procedure suggested in 'Lesson 15, Colour'.

5. Find 'Q' and colour

10 minutes

Find 'Q' and colour.

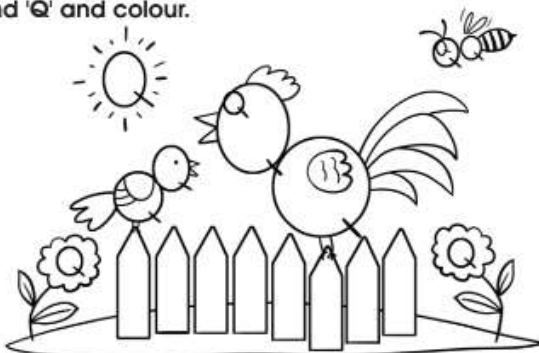

- Ask the students to do the task individually.
- Ask them to look at the picture and look for the letter 'Q'.
- Tell them that they have to colour the letter when they find it.
- Move around the class and ensure that each student has found and coloured all Qs in the picture.

6. Write

10 minutes

Write.



- Follow the procedure as suggested in 'Lesson 15, Write'.

Homework

- Draw a picture of queen using the letter Q.

Lesson 51

Qq

In this lesson, there are six topics to cover:

1. Read (Reading)
2. Look and say (Listening, speaking and reading)
3. Write (Writing)
4. Read (Reading)
5. Read and discuss (Reading)
6. Copy (Writing)

Objectives:

- Read the letters: a, b, c, d, e, f, g, h, i, j, k, l, m, n, o, p and q.
- Say the words that have 'q' in initial position.
- Read the words correctly.
- Read a phrase correctly.
- Trace and write the letters 'Q' and 'q'.

Materials:

- Letter cards (a -q)
- Pictures and word cards (queen, quill and quilt; highlighting the initial letter 'q'.)

Before you teach:

1. Study the workbook thoroughly.
2. Have the materials ready.

1. Read 5 minutes

Read.

q o n p m

- Show the letter cards one by one and ask the students to read the letter on the card.
- If they can't, read yourself and ask them to follow you.

2. Look and say 15 minutes

- Follow the procedure suggested in 'Lesson 16, Look and say'.

Look and say.

Qq

queen



quill



quilt



3. Write

10 minutes

- Follow the procedure as suggested in 'Lesson 15, Write'.

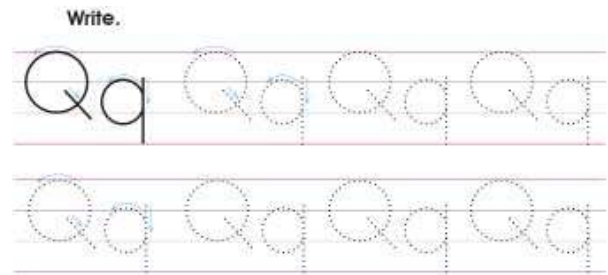

4. Read

10 minutes

- Follow the procedure suggested in 'Lesson 24, Read'.

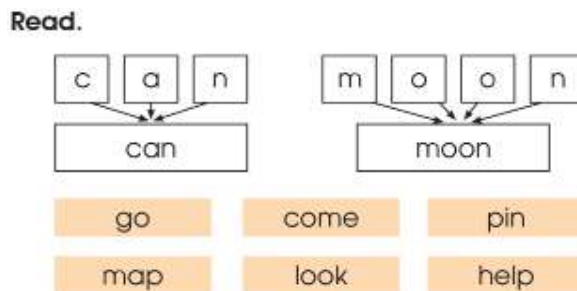

5. Read and discuss

10 minutes

- Follow the procedure suggested in 'Lesson 49, Read and discuss'.



6. Copy

10 minutes

- Follow the procedure as suggested in 'Lesson 16, Copy'.

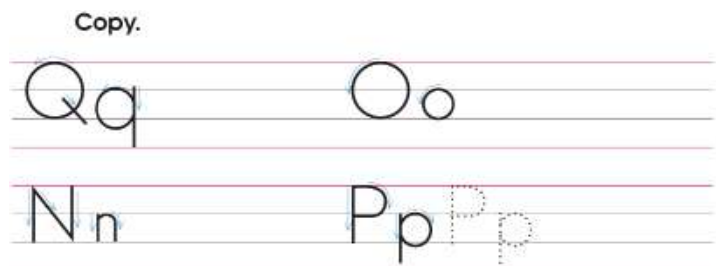

Homework

- Write the letters Aa - Qq.

Lesson 52

Rr

In this lesson, there are six topics to cover:

1. Listen and say (Listening and speaking)
2. Look and discuss (Listening and speaking)
3. Listen and say (Listening, speaking and reading)
4. Colour (Reading)
5. Find the way and colour (Reading)
6. Write (Writing)

Objectives:

- Say the words: moon, map, look and help orally.
- Say the words that have the letter 'r' in initial position.
- Draw a picture of a rabbit using the letter 'R'.
- Trace over letter 'Rr'.

Materials:

Word cards: moon, map, look and help, and picture cards: rat, rose, rabbit and ring

Before you teach:

1. Study the workbook thoroughly.
2. Have the materials ready.

1. Listen and say 5 minutes

- Show the word cards one by one and **Listen and say.**
ask the students to read the words. **moon** **map** **look** **help**
- If they can't, read yourself and ask them to follow you.

2. Look and discuss 5 minutes

- Follow the procedure suggested in 'Lesson 15, 'Look and discuss'.

Look and discuss.



3. Listen and say

15 minutes

Listen and say.



r



- Follow the procedure suggested in 'Lesson 15, Listen and say'.

4. Colour

15 minutes

Colour.



- Follow the procedure suggested in lesson 15, 'Colour'.

5. Find the way and colour

10 minutes

Find the way and colour.

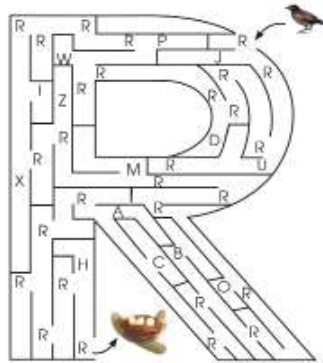

- Follow the procedure suggested in 'Lesson 43, Find and trace the way'.

6. Write

10 minutes

Write.



- Follow the procedure as suggested in 'Lesson 15, Write'.

Homework

- Draw a picture of a robot using the letter R.

Lesson 53

Rr

In this lesson, there are six topics to cover:

1. Read (Reading)
2. Look and say (Listening, speaking and reading)
3. Write (Writing)
4. Read (Reading)
5. Read and discuss (Reading)
6. Copy (Writing)

Objectives:

- Read the letters: a, b, c, d, e, f, g, h, i, j, k, l, m, n, o, p, q and r.
- Say the words that have 'r' in initial position.
- Read the words correctly.
- Read the text correctly.
- Trace and write the letters 'Q' and 'q'.

Materials:

- Letter cards (a -r)
- Pictures and word cards (queen, quill and quilt; highlighting the initial letter 'r'.)

Before you teach:

1. Study the workbook thoroughly.
2. Have the materials ready.

1. Read 5 minutes

Read.

r o p n q

- Show the letter cards one by one and ask the students to read the letter on the card.
- If they can't, read yourself and ask them to follow you.

2. Look and say 15 minutes

Look and say.

Rr

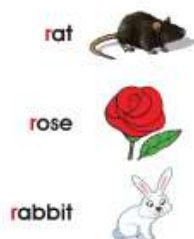

- Follow the procedure suggested in 'Lesson 16, 'Look and say'.

3. Write

10 minutes

- Follow the procedure as suggested in lesson 15, 'Write'.

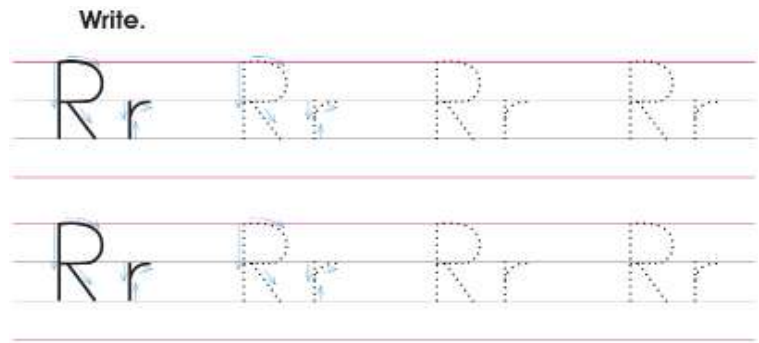

4. Read

10 minutes

- Follow the procedure suggested in 'Lesson 24, Read'.

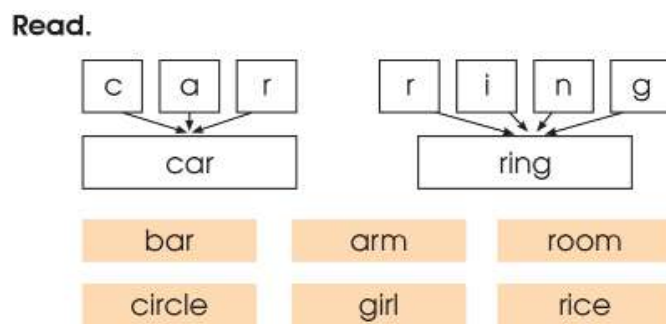

5. Read and discuss

- Follow the procedure suggested in 'Lesson 49, Read and discuss'.



6. Copy

10 minutes

- Follow the procedure as suggested in 'Lesson 16, Copy'.

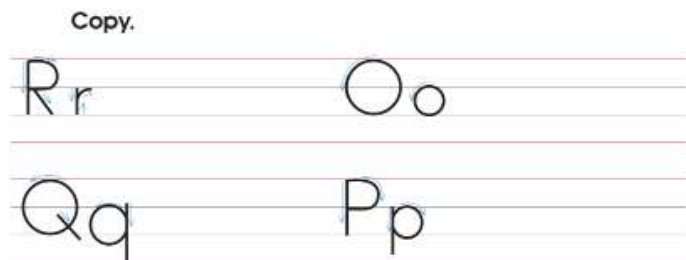

Homework

- Write the letters Aa - Rr.

Lesson 54

Ss

In this lesson, there are six topics to cover:

1. Listen and say (Listening and speaking)
2. Look and discuss (Listening and speaking)
3. Listen and say (Listening, speaking and reading)
4. Colour (Reading)
5. Colour the pictures that begin with s
6. Write (Writing)

Objectives:

- Say the words: ring, car, girl and rice orally.
- Say the words that have the letter 's' in initial position.
- Draw a picture of a swan using the letter 'S'.
- Identify the pictures that have 's' in the initial position of their names.
- Trace over letter 'Ss'.

Materials:

Word cards: ring, car, girl and rice, and picture cards: snake, star, sun and snow

Before you teach:

1. Study the workbook thoroughly.
2. Have the materials ready.

1. Listen and say 5 minutes

- Show the word cards one by one and ask the students to read the words. Listen and say.
ring car girl rice
- If they can't, read yourself and ask them to follow you.

2. Look and discuss 5 minutes

- Follow the procedure suggested in 'Lesson 15, Look and discuss'.

Look and discuss.



3. Listen and say

15 minutes

Listen and say.



- Follow the procedure suggested in 'Lesson 15, Listen and say'.

4. Colour

15 minutes

Colour.

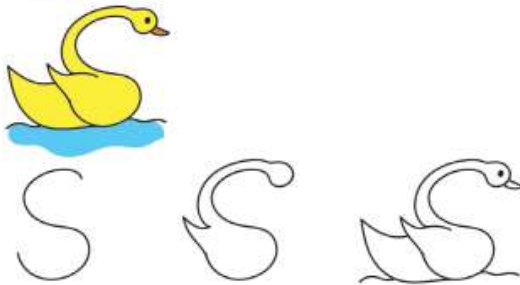

- Follow the procedure suggested in 'Lesson 15, Colour'.

5. Colour the pictures that begin with 's'

10 minutes

Colour (the pictures that begin with **s**).



- Follow the procedure suggested in 'Lesson 24, Colour the picture that starts with 'e'.

6. Write

10 minutes

Write.

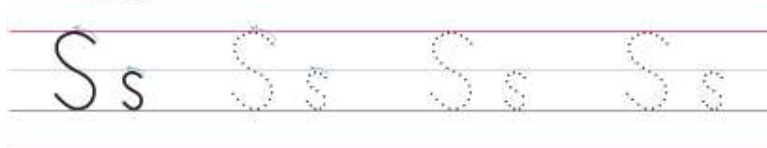

- Follow the procedure as suggested in 'Lesson 15, Write'.

Homework

- Draw a picture of a swan using the letter S.

Lesson 55

Ss

In this lesson, there are six topics to cover:

1. Read (Reading)
2. Look and say (Listening, speaking and reading)
3. Write (Writing)
4. Read (Reading)
5. Read and discuss (Reading)
6. Copy (Writing)

Objectives:

- Read the letters: a, b, c, d, e, f, g, h, i, j, k, l, m, n, o, p, q, r and s.
- Say the words that have 's' in initial position.
- Read the words correctly.
- Read the text correctly.
- Trace and write the letters 'S' and 's'.

Materials:

- Letter cards (a -s)
- Pictures and word cards (sun, star and swan; highlighting the initial letter 's'.)

Before you teach:

1. Study the workbook thoroughly.
2. Have the materials ready.

1. Read 5 minutes

Read.

s q p r o

- Show the letter cards one by one and ask the students to read the letter on the card.
- If they can't, read yourself and ask them to follow you.

2. Look and say 15 minutes

Look and say.

Ss



- Follow the procedure suggested in 'Lesson 16, Look and say'.

3. Write

10 minutes

- Follow the procedure as suggested in 'Lesson 15, Write'.

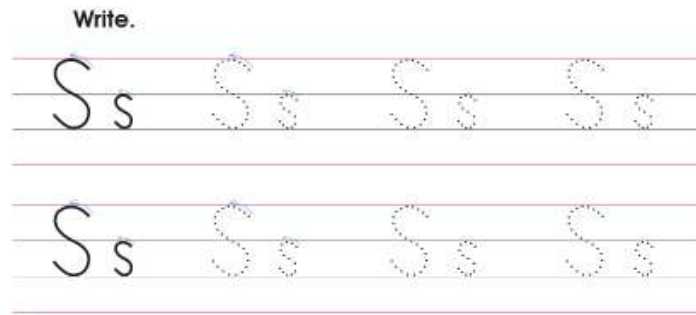

4. Read

10 minutes

- Follow the procedure suggested in 'Lesson 24, Read'.

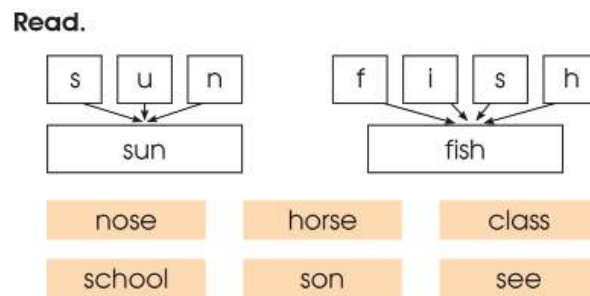

5. Read and discuss

- Follow the procedure suggested in lesson 49, 'Read and discuss'.



6. Copy

10 minutes

- Follow the procedure as suggested in 'Lesson 16, Copy'.

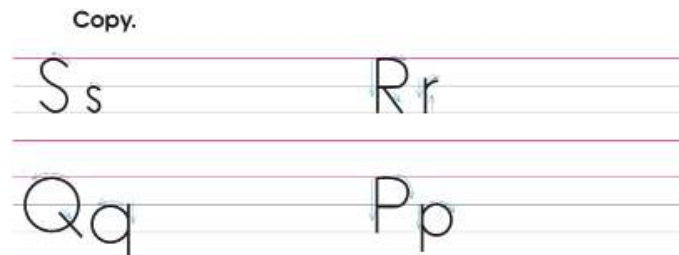

Homework

- Write the letters Aa - Ss.

Lesson 56

Tt

In this lesson, there are six topics to cover:

1. Listen and say (Listening and speaking)
2. Look and discuss (Listening and speaking)
3. Listen and say (Listening, speaking and reading)
4. Colour (Reading)
5. Listen and say (Rhyme)
6. Write (Writing)

Objectives:

- Say the words: nose, horse, fish and school orally.
- Say the words that have the letter 't' in initial position.
- Draw a picture of a tent using the letter 'T'.
- Sing and enjoy the rhyme.
- Trace over letter 'Tt'.

Materials:

Word cards: nose, horse, fish and school, and picture cards: tiger, tap, table and tree

Before you teach:

1. Study the workbook thoroughly.
2. Have the materials ready.
3. Learn to sing the rhyme (<https://www.youtube.com/watch?v=7X0Q4F--g0s>)

1. Listen and say

5 minutes

- Show the word cards one by one and ask the students to read the words.
- If they can't, read yourself and ask them to follow you.

Listen and say.

nose horse fish school

2. Look and discuss

5 minutes

- Follow the procedure suggested in 'Lesson 15, Look and discuss'.

Look and discuss.



3. Listen and say

15 minutes

Listen and say.



- Follow the procedure suggested in 'Lesson 15, 'Listen and say'.

4. Colour

15 minutes

Colour.

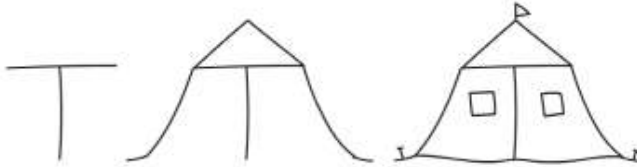

- Follow the procedure suggested in 'Lesson 15, Colour'.

5. Listen and say

10 minutes

Listen and say.



Teddy bear, teddy bear,
turn around.

Teddy bear, teddy bear,
touch the ground.



- Follow the procedure suggested in 'Lesson 16, Listen and sing'.

6. Write

10 minutes

Write.



- Follow the procedure as suggested in 'Lesson 15, Write'.

Homework

- Draw a picture of a tent using the letter T.

Lesson 57

Tt

In this lesson, there are six topics to cover:

1. Read (Reading)
2. Look and say (Listening, speaking and reading)
3. Write (Writing)
4. Read (Reading)
5. Read and discuss (Reading)
6. Copy (Writing)

Objectives:

- Read the letters: a, b, c, d, e, f, g, h, i, j, k, l, m, n, o, p, q, r, s and t.
- Say the words that have 't' in initial position.
- Read the words correctly.
- Read the text correctly.
- Trace and write the letters 'T' and 't'.

Materials:

- Letter cards (a -t)
- Pictures and word cards (sun, star and swan; highlighting the initial letter 't'.)

Before you teach:

1. Study the workbook thoroughly.
2. Have the materials ready.

1. Read

5 minutes

Read.

t r s q p

- Show the letter cards one by one and ask the students to read the letter on the card.
- If they can't, read yourself and ask them to follow you.

2. Look and say

15 minutes

Look and say.

Tt

tiger 

table 

tree 

- Follow the procedure suggested in 'Lesson 16, Look and say'.

3. Write

10 minutes

- Follow the procedure as suggested in 'Lesson 15, Write'.

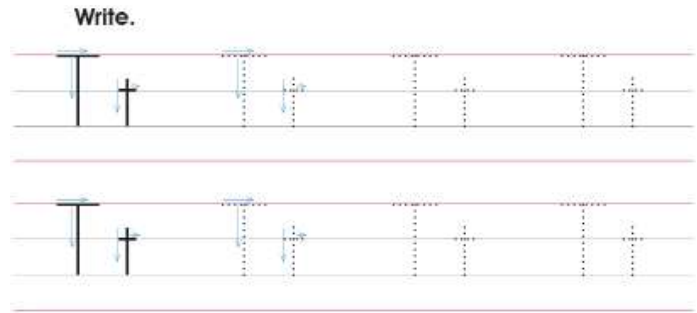

4. Read

10 minutes

- Follow the procedure suggested in lesson 24, Read.

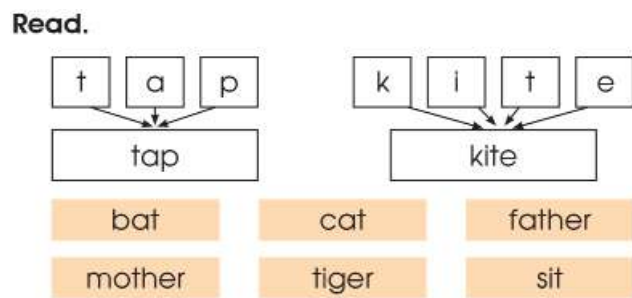

5. Read and discuss

- Follow the procedure suggested in lesson 49, 'Read and discuss'.

Read and discuss.



6. Copy

10 minutes

- Follow the procedure as suggested in 'Lesson 16, Copy'.

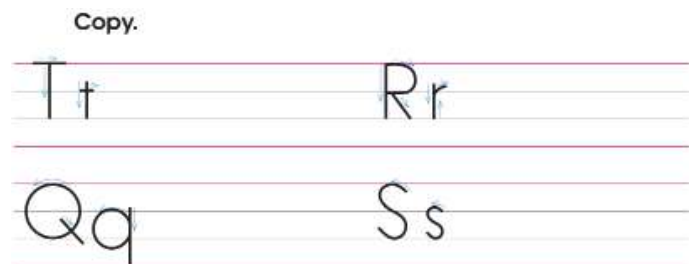

Homework

- Write the letters Aa - Tt.

Lesson 58

Pp - Tt

In this lesson, there are five topics to cover:

1. Listen and say (Listening, speaking and reading)
2. Match (Reading)
3. Write the missing letter. (Writing)
4. Find the words (Reading)
5. Write (Writing)

Objectives:

- Match the picture with its name.
- Blend onset with rime.
- Identify words.
- Write words.

Materials:

- Alphabet cards (a-t)
- Cards containing 'at', 'in' and 'an'

Before you teach:

1. Study the workbook thoroughly.
2. Have the materials ready.

1. Listen and say

20 minutes

- Paste the card 'at' on the display board.
- Now ask them to put the letter card 'c' with the card 'at'.
- Ask them to combine the cards and read the word that is formed; bat.
- Put the letter cards with the letters 'c', 'm' and 'r' respectively with the card 'at' as before and ask them to read the words loud.
- Repeat the similar process for other two, too.

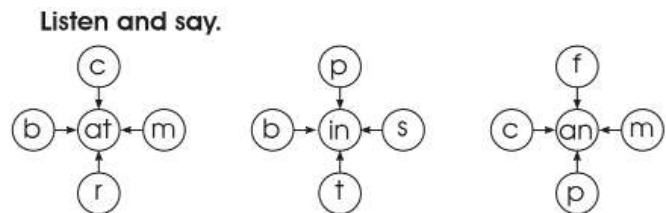

2. Match

10 minutes

- Ask the students to look at the pictures and name them.
- Help them if they can't.

Match.

net
pet
bet



cut
cot
cat



fog
log
dog



pot
pet
pat



mad
man
map



log
lap
lip



- Once they learn the name, ask them: to read the words given with each picture.
- Tell them that they have to match the picture with its name given there.
- Now ask them to match.

- Move around the class and help them while they are doing the task.
- After they complete, check it thoroughly.

3. Write the missing letter. 10 minutes

- Make the students do this task individually.
- Tell them to begin from the bottom of the ladder.
- Tell them to look at the picture at the bottom. Ask them to name it.
- Then ask them to read the word at the bottom of the ladder. Then ask them if the picture and the word match or not.
- Tell them that they have to look at the picture and fill in the suitable initial letter to write the name of the picture.
- Ask the students to do the task.
- Move around the class and help them.

Write the missing letter.



C	A	T
.....	A	P
M	P
.....	A	T
.....	O	T
D	O	G



4. Find the words 10 minutes

- Ask the students to look at the picture.
- Ask them to name the picture.
- Tell them to find the name of the picture in the box.
- Once they find it, ask them to circle the word.
- Repeat the similar procedure for other pictures too.

Find the words.

L	L	E	A	F	A	T	L
W	W	O	V	F	P	O	D
A	D	R	B	D	P	M	K
Y	S	A	E	H	L	A	F
W	N	N	U	L	E	T	I
B	A	G	C	I	P	O	A
I	K	E	H	X	D	P	U
T	E	T	R	A	I	N	A



5. Write

10 minutes

- Follow the procedure suggested in unit 36 'Write correct words.

Write.

pen moon ring

fish kite tap

Homework

- Write the letters Aa - Tt.

Lesson 59

Uu

In this lesson, there are six topics to cover:

1. Listen and say (Listening and speaking)
2. Look and discuss (Listening and speaking)
3. Listen and say (Listening, speaking and reading)
4. Colour (Reading)
5. Find and trace the way (Reading)
6. Write (Writing)

Objectives:

- Say the words: orange, snake, train and tomato orally.
- Say the words that have the letter 'u' in initial position.
- Draw a picture of an umbrella using the letter 'U'.
- Recognise the letter 'u'.
- Trace over letter 'Uu'.

Materials:

Word cards: orange, snake, train and tomato, and picture cards: umbrella, uniform, unicorn and underwear

Before you teach:

1. Study the workbook thoroughly.
2. Have the materials ready.

1. Listen and say

5 minutes

- Show the word cards one by one and ask the students to read the words.
- If they can't, read yourself and ask them to follow you.

Listen and say.

orange snake train tomato

2. Look and discuss

5 minutes

- Follow the procedure suggested in 'Lesson 15, Look and discuss'.

Look and discuss.



3. Listen and say

15 minutes

Listen and say.



- Follow the procedure suggested in 'Lesson 15, 'Listen and say'.

4. Colour

15 minutes

Colour.



- Follow the procedure suggested in 'Lesson 15, Colour'.

5. Find and trace the way

10 minutes

Find and trace (the way).

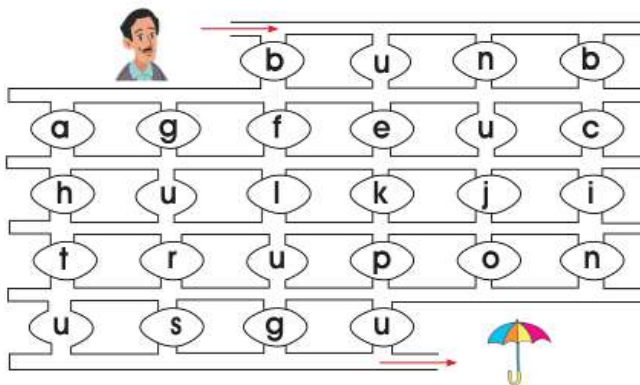

- Follow the procedure suggested in 'Lesson 43, Find and trace the way'.

6. Write

10 minutes

Write.

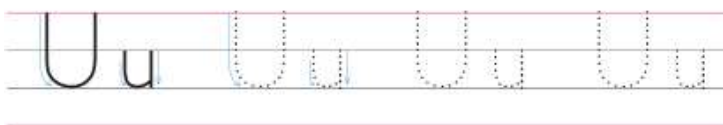

- Follow the procedure as suggested in 'Lesson 15, Write'.

Homework

- Draw a picture of an umbrella using the letter U.

Lesson 60

Uu

In this lesson, there are six topics to cover:

1. Read (Reading)
2. Look and say (Listening, speaking and reading)
3. Write (Writing)
4. Read (Reading)
5. Read and discuss (Reading)
6. Copy (Writing)

Objectives:

- Read the letters: a, b, c, d, e, f, g, h, i, j, k, l, m, n, o, p, q, r, s, t and u.
- Say the words that have 'u' in initial position.
- Read the words correctly.
- Read the text correctly.
- Trace and write the letters 'U' and 'u'.

Materials:

- Letter cards (a -u)
- Pictures and word cards (umbrella, under and up; highlighting the initial letter 'u')

Before you teach:

1. Study the workbook thoroughly.
2. Have the materials ready.

1. Read 5 minutes

Read.

u r t q s

- Show the letter cards one by one and ask the students to read the letter on the card.
- If they can't, read yourself and ask them to follow you.

2. Look and say 15 minutes

Look and say.

Uu



- Follow the procedure suggested in 'Lesson 16, Look and say'.

3. Write

10 minutes

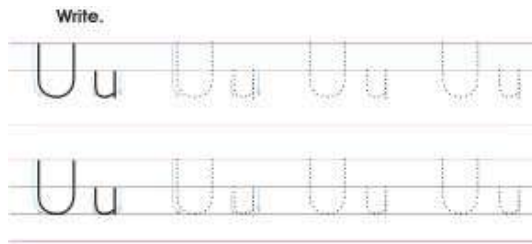

- Follow the procedure as suggested in lesson 15, 'Write'.

4. Read

10 minutes

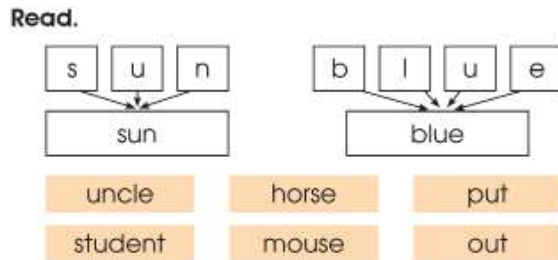

- Follow the procedure suggested in 'Lesson 24, Read'.

5. Read and discuss

Read and discuss.



Uncle has an umbrella.

- Follow the procedure suggested in 'Lesson 49, Read and discuss'.

6. Copy

10 minutes

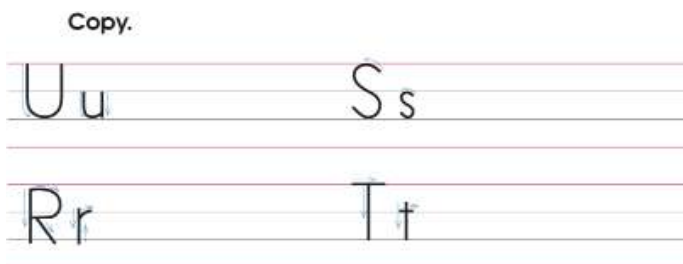

- Follow the procedure as suggested in 'Lesson 16, Copy'.

Homework

- Write the letters Aa - Uu.

Lesson 61

Vv

In this lesson, there are six topics to cover:

1. Listen and say (Listening and speaking)
2. Look and discuss (Listening and speaking)
3. Listen and say (Listening, speaking and reading)
4. Colour (Reading)
5. Find the way (Reading)
6. Write (Writing)

Objectives:

- Say the words: student, mouth, uncle, house orally.
- Say the words that have the letter 'v' in initial position.
- Draw a picture of an vulture using the letter 'V'.
- Recognise the letter 'v'.
- Trace over letter 'Vv'.

Materials:

Word cards: student, mouth, uncle, house, and picture cards: van, violin, vase and vulture

Before you teach:

1. Study the workbook thoroughly.
2. Have the materials ready.

1. Listen and say

5 minutes

- Show the word cards one by one and ask the students to read the words.
- If they can't, read yourself and ask them to follow you.

Listen and say.
student mouth uncle house

2. Look and discuss

5 minutes

- Follow the procedure suggested in 'Lesson 15, Look and discuss'.



3. Listen and say

15 minutes

Listen and say.



- Follow the procedure suggested in 'Lesson 15, Listen and say'.

4. Colour

15 minutes

Colour.



- Follow the procedure suggested in lesson 15, 'Colour'.

5. Find and trace the way

10 minutes

Find (the way).

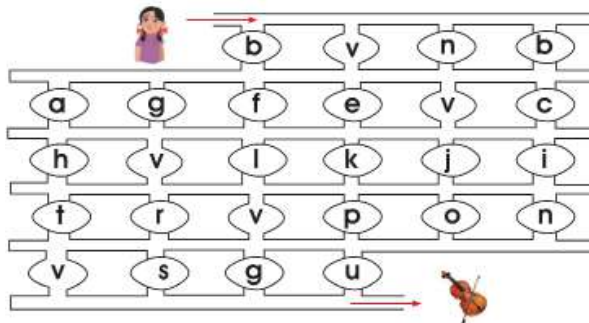

- Follow the procedure suggested in 'Lesson 43, Find and trace the way'.

6. Write

10 minutes

Write.

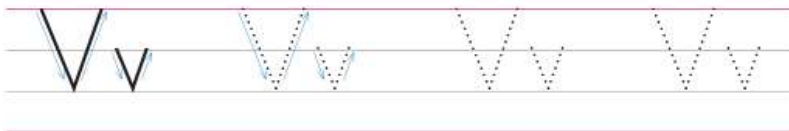

- Follow the procedure as suggested in 'Lesson 15, Write'.

Homework

- Draw a picture of a vulture using the letter V.

Lesson 62

Vv

In this lesson, there are six topics to cover:

1. Read (Reading)
2. Look and say (Listening, speaking and reading)
3. Write (Writing)
4. Read (Reading)
5. Read and discuss (Reading)
6. Copy (Writing)

Objectives:

- Read the letters: a, b, c, d, e, f, g, h, i, j, k, l, m, n, o, p, q, r, s, t, u and v.
- Say the words that have 'v' in initial position.
- Read the words correctly.
- Read the text correctly.
- Trace and write the letters 'V' and 'v'.

Materials:

- Letter cards (a -v)
- Pictures and word cards (van, vase, vest; highlighting the initial letter 'v'.)

Before you teach:

1. Study the workbook thoroughly.
2. Have the materials ready.

1. Read 5 minutes

Read.

v r t u s

- Show the letter cards one by one and ask the students to read the letter on the card.
- If they can't, read yourself and ask them to follow you.

2. Look and say 15 minutes

Look and say.



- Follow the procedure suggested in 'Lesson 16, Look and say'.

3. Write

10 minutes

- Follow the procedure as suggested in 'Lesson 15, Write'.

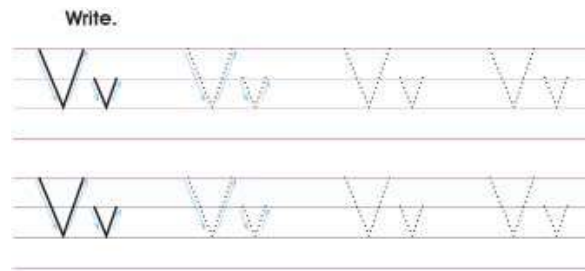

4. Read

10 minutes

- Follow the procedure suggested in 'Lesson 24, Read'.

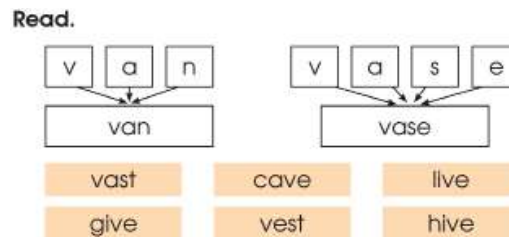

5. Read and discuss

- Follow the procedure suggested in 'Lesson 49, Read and discuss'.

Read and discuss.

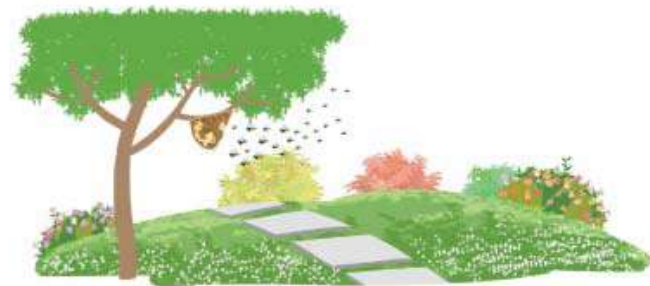

Bees live in hives.

6. Copy

10 minutes

- Follow the procedure as suggested in 'Lesson 16, Copy'.

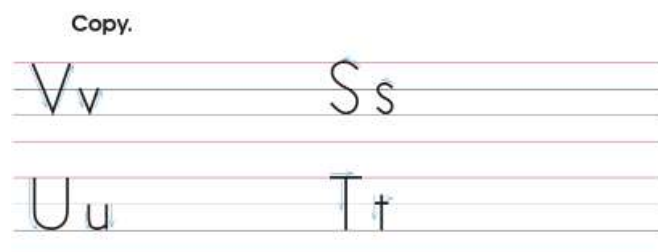

Homework

- Write the letters Aa - Vv.

Lesson 63

Ww

In this lesson, there are six topics to cover:

1. Listen and say (Listening and speaking)
2. Look and discuss (Listening and speaking)
3. Listen and say (Listening, speaking and reading)
4. Colour (Reading)
5. Circle the odd picture
6. Write (Writing)

Objectives:

- Say the words: give, vest, live and cave orally.
- Say the words that have the letter 'w' in initial position.
- Draw a picture of a watermelon using the letter 'W'.
- Recognise the words that begin with the letter 'w'.
- Trace over letter 'Ww'.

Materials:

Word cards: give, vest, live and cave, and picture cards: watch, wheel, window and web.

Before you teach:

1. Study the workbook thoroughly.
2. Have the materials ready.

1. Listen and say

5 minutes

- Show the word cards one by one and ask the students to read the words.
- If they can't, read yourself and ask them to follow you.

Listen and say.

give

vest

live

cave

2. Look and discuss

5 minutes

- Follow the procedure suggested in 'Lesson 15, Look and discuss'.

Look and discuss.



3. Listen and say 15 minutes

Listen and say.



W



- Follow the procedure suggested in 'Lesson 15, Listen and say'.

4. Colour 15 minutes

Colour.



- Follow the procedure suggested in lesson 15, 'Colour'.

5. Circle (the odd picture) 10 minutes

Circle (the odd picture).



- Ask the students to look at the pictures in each row.
- Ask them to name the pictures.
- Once they name the picture, ask them to find out the initial letter in each name.
- Tell them to circle the picture which does not have 'w' in the beginning of its name.

6. Write 10 minutes

Write.

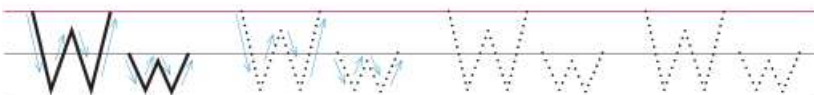

- Follow the procedure as suggested in 'Lesson 15, Write'.

Homework

- Draw a picture of a watermelon using the letter W.

Lesson 64

Ww

In this lesson, there are six topics to cover:

1. Read (Reading)
2. Look and say (Listening, speaking and reading)
3. Write (Writing)
4. Read (Reading)
5. Read and discuss (Reading)
6. Copy (Writing)

Objectives:

- Read the letters: a, b, c, d, e, f, g, h, i, j, k, l, m, n, o, p, q, r, s, t, u, v and w.
- Say the words that have 'w' in initial position.
- Read the words correctly.
- Read the text correctly.
- Trace and write the letters 'W' and 'w'.

Materials:

- Letter cards (a -w)
- Pictures and word cards (van, vase, vest; highlighting the initial letter 'w'.)

Before you teach:

1. Study the workbook thoroughly.
2. Have the materials ready.

1. Read 5 minutes

Read.

w s v u t

- Show the letter cards one by one and ask the students to read the letter on the card.
- If they can't, read yourself and ask them to follow you.

2. Look and say 15 minutes

Look and say.



- Follow the procedure suggested in 'Lesson 16, 'Look and say'.

3. Write

10 minutes

- Follow the procedure as suggested in 'Lesson 15, Write'.

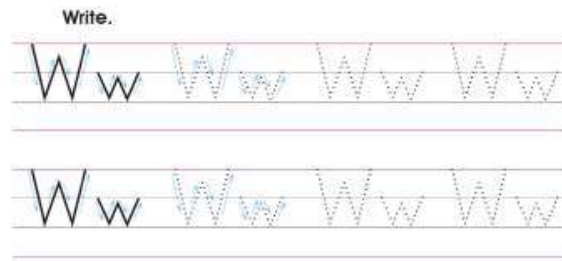

4. Read

10 minutes

- Follow the procedure suggested in 'Lesson 24, Read'.

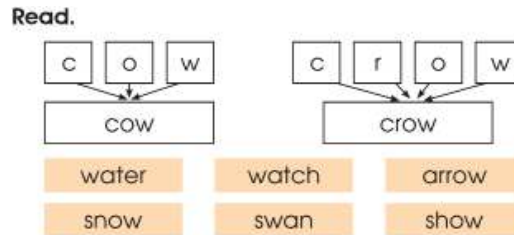

5. Read and discuss

- Follow the procedure suggested in 'Lesson 49, Read and discuss'.

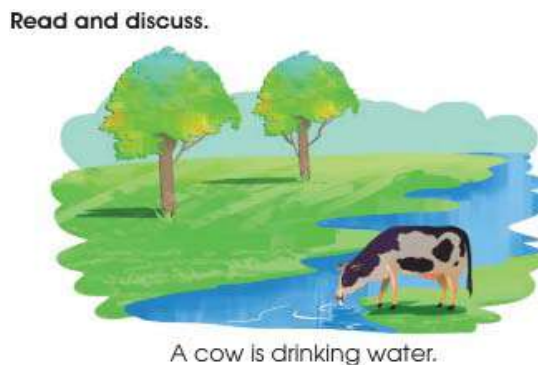

6. Copy

10 minutes

- Follow the procedure as suggested in 'Lesson 16, Copy'.

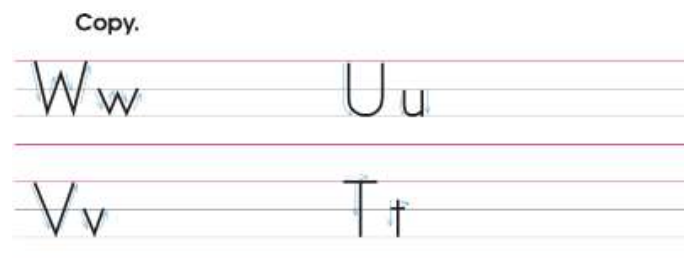

Homework

- Write the letters Aa - Ww.

Lesson 65

Xx

In this lesson, there are six topics to cover:

1. Listen and say (Listening and speaking)
2. Look and discuss (Listening and speaking)
3. Listen and say (Listening, speaking and reading)
4. Colour (Reading)
5. Circle the odd picture
6. Write (Writing)

Objectives:

- Say the words: crow, water, show and snow orally.
- Say the words that have the letter 'x' in initial position.
- Draw a picture of a x-ray using the letter 'X'.
- Match the words having 'x' with the pictures.
- Trace over letter 'Xx'.

Materials:

Word cards: crow, water, show and snow, and picture cards: x-ray, xylophone and xerox.

Before you teach:

1. Study the workbook thoroughly.
2. Have the materials ready.

1. Listen and say

5 minutes

- Show the word cards one by one and ask the students to read the words.
- If they can't, read yourself and ask them to follow you.

Listen and say.

crow water show snow

2. Look and discuss

5 minutes

- Follow the procedure suggested in 'Lesson 15, Look and discuss'.

Look and discuss.



3. Listen and say 15 minutes

Listen and say.



X



- Follow the procedure suggested in 'Lesson 15, 'Listen and say'.

4. Colour 15 minutes

Colour.

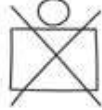

- Follow the procedure suggested in 'Lesson 15, 'Colour'.

5. Match 10 minutes

Match.

fox
box
six
ox
axe

6



- Ask the students to read the words in the first column.
- Then ask the students to look at the pictures in the next column and name the pictures.
- Now, ask the students to match the words with the pictures.
- Tell them to do the task individually.

6. Write 10 minutes

Write.

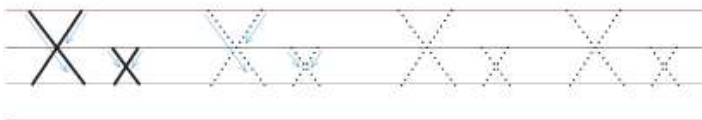

- Follow the procedure as suggested in 'Lesson 15, 'Write'.

Homework

- Draw a picture of a x-ray using the letter X.

Lesson 66

Xx

In this lesson, there are six topics to cover:

1. Read (Reading)
2. Look and say (Listening, speaking and reading)
3. Write (Writing)
4. Read (Reading)
5. Read and discuss (Reading)
6. Copy (Writing)

Objectives:

- Read the letters: a, b, c, d, e, f, g, h, i, j, k, l, m, n, o, p, q, r, s, t, u, v, w and x.
- Say the words that have 'x' in initial position.
- Read the words correctly.
- Read the text correctly.
- Trace and write the letters 'X' and 'x'.

Materials:

- Letter cards (a -x)
- Pictures and word cards (van, vase, vest; highlighting the initial letter 'w'.)

Before you teach:

1. Study the workbook thoroughly.
2. Have the materials ready.

1. Read

5 minutes

Read.

x w v u t

- Show the letter cards one by one and ask the students to read the letter on the card.
- If they can't, read yourself and ask them to follow you.

2. Look and say

15 minutes

Look and say.

Xx

x-ray



xerox



xylophone



- Follow the procedure suggested in 'Lesson 16, Look and say'.

3. Write

10 minutes

- Follow the procedure as suggested in 'Lesson 15, Write'.

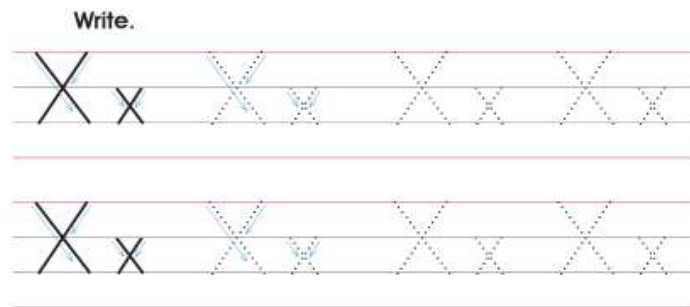

4. Read

10 minutes

- Follow the procedure suggested in 'Lesson 24, Read'.

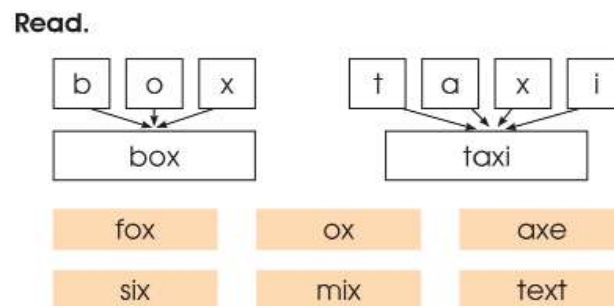

5. Read and discuss

- Follow the procedure suggested in lesson 49, 'Read and discuss'.

Read and discuss.



A fox and an ox are in the box.

6. Copy

10 minutes

- Follow the procedure as suggested in 'Lesson 16, Copy'.

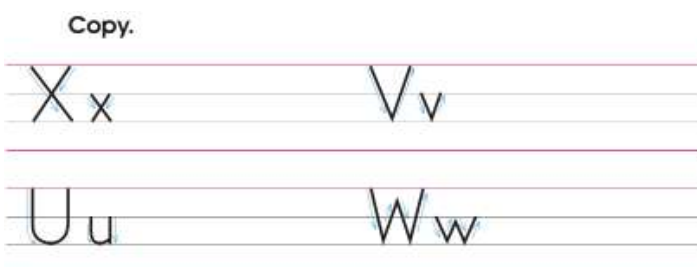

Homework

- Write the letters Aa - Xx.

Lesson 67

Yy

In this lesson, there are six topics to cover:

1. Listen and say (Listening and speaking)
2. Look and discuss (Listening and speaking)
3. Listen and say (Listening, speaking and reading)
4. Colour (Reading)
5. Find the way and colour (Reading)
6. Write (Writing)

Objectives:

- Say the words: axe, box, taxi and fox orally.
- Say the words that have the letter 'y' in initial position.
- Draw a picture of a yak using the letter 'Y'.
- Recognise the letter 'y'.
- Trace over letter 'Yy'.

Materials:

Word cards: crow, water, show and snow, and picture cards: yak, yacht, yellow and yam.

Before you teach:

1. Study the workbook thoroughly.
2. Have the materials ready.

1. Listen and say

5 minutes

- Show the word cards one by one and ask the students to read the words.
- If they can't, read yourself and ask them to follow you.

Listen and say.

axe

box

taxi

fox

2. Look and discuss

5 minutes

- Follow the procedure suggested in 'Lesson 15, 'Look and discuss'.

Look and discuss.

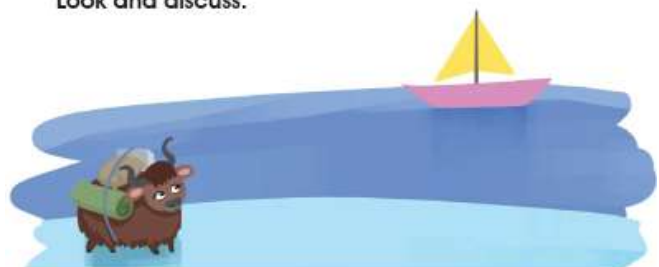

3. Listen and say

15 minutes

Listen and say.



- Follow the procedure suggested in 'Lesson 15, 'Listen and say'.

4. Colour

15 minutes

Colour.

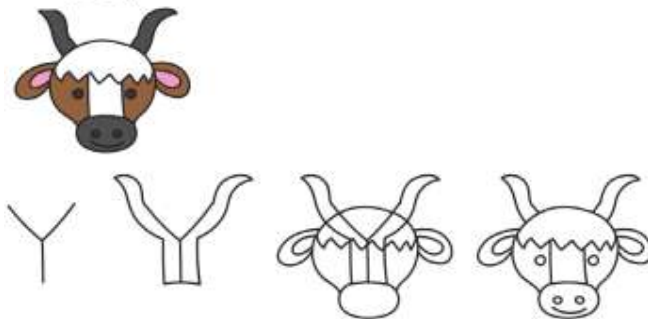

- Follow the procedure suggested in 'Lesson 15, 'Colour'.

5. Find the way and colour

10 minutes

Find the way and colour.

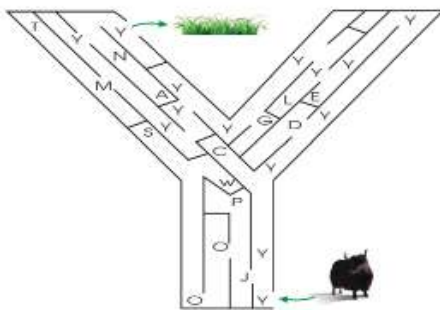

- Follow the procedure suggested in lesson 43, 'Find and trace the way'.

6. Write

10 minutes

Write.



- Follow the procedure as suggested in 'Lesson 15, Write'.

Homework

- Draw a picture of a yak using the letter Y.

Lesson 68

Yy

In this lesson, there are six topics to cover:

1. Read (Reading)
2. Look and say (Listening, speaking and reading)
3. Write (Writing)
4. Read (Reading)
5. Read and discuss (Reading)
6. Copy (Writing)

Objectives:

- Read the letters: a, b, c, d, e, f, g, h, i, j, k, l, m, n, o, p, q, r, s, t, u, v, w, x and y.
- Say the words that have 'y' in initial position.
- Read the words correctly.
- Read the text correctly.
- Trace and write the letters 'Y' and 'y'.

Materials:

- Letter cards (a -y)
- Pictures and word cards (yak, yellow and yam; highlighting the initial letter 'y'.)

Before you teach:

1. Study the workbook thoroughly.
2. Have the materials ready.

1. Read 5 minutes

Read.

x w v u y

- Show the letter cards one by one and ask the students to read the letter on the card.
- If they can't, read yourself and ask them to follow you.

2. Look and say 15 minutes

Look and say.

Yy

yak



yellow



yam



- Follow the procedure suggested in 'Lesson 16, Look and say'.

3. Write

10 minutes

- Follow the procedure as suggested in 'Lesson 15, 'Write'.

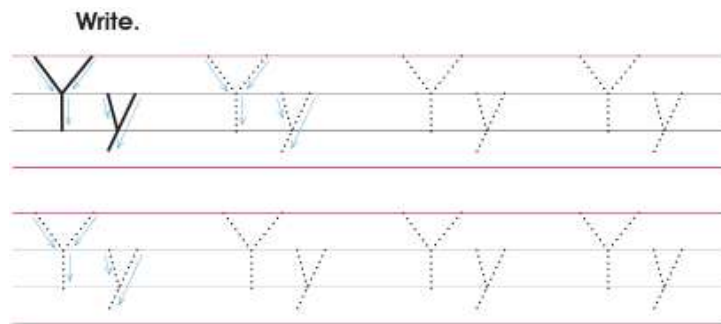

4. Read

10 minutes

- Follow the procedure suggested in 'Lesson 24, Read'.

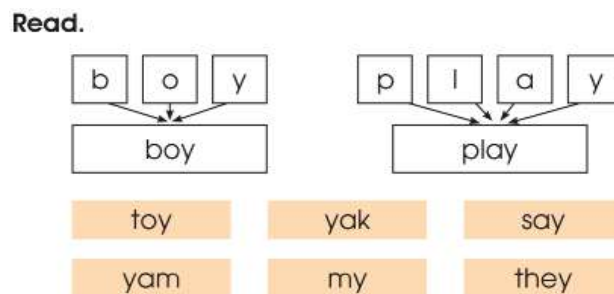

5. Read and discuss

- Follow the procedure suggested in 'Lesson 49, 'Read and discuss'.

Read and discuss.



A boy likes a toy.

6. Copy

10 minutes

- Follow the procedure as suggested in 'Lesson 16, Copy'.

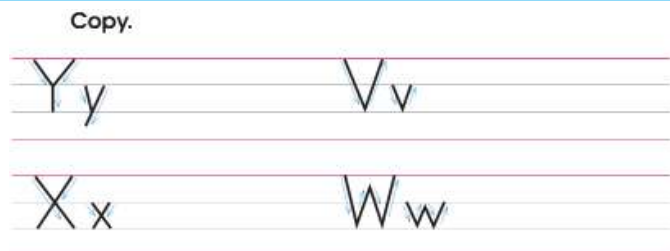

Homework

- Write the letters Aa - Yy.

Lesson 69

Zz

In this lesson, there are six topics to cover:

1. Listen and say (Listening and speaking)
2. Look and discuss (Listening and speaking)
3. Listen and say (Listening, speaking and reading)
4. Colour (Reading)
5. Find and colour the picture that starts with z.
6. Write (Writing)

Objectives:

- Say the words: play, boy, toy and yak orally.
- Say the words that have the letter 'z' in initial position.
- Draw a picture of a zebra using the letter 'Z'.
- Recognise the pictures that have 'z' in initial position of their names.
- Trace over letter 'Zz'.

Materials:

Word cards: play, boy, toy and yak, and picture cards: zebra, zero, zip and zoo

Before you teach:

1. Study the workbook thoroughly.
2. Have the materials ready.

1. Listen and say

5 minutes

- Show the word cards one by one and ask the students to read the words.
- If they can't, read yourself and ask them to follow you.

Listen and say.

play boy toy yak

2. Look and discuss

5 minutes

- Follow the procedure suggested in 'Lesson 15, Look and discuss'.

Look and discuss.

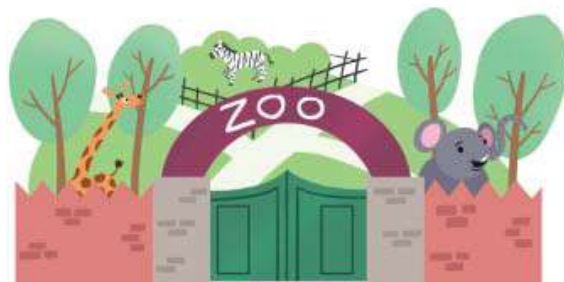

3. Listen and say

15 minutes

Listen and say.



O

Z



- Follow the procedure suggested in 'Lesson 15, 'Listen and say'.

4. Colour

15 minutes

Colour.

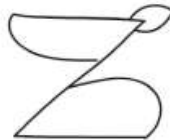
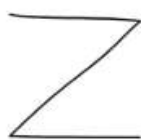

- Follow the procedure suggested in lesson 15, 'Colour'.

5. Find (and colour the picture that starts with Z) 10 minutes

Find (and colour the picture that starts with Z).

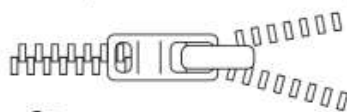

- Follow the procedure suggested in lesson 24, 'Colour the picture that starts with 'e'.

6. Write

10 minutes

Write.

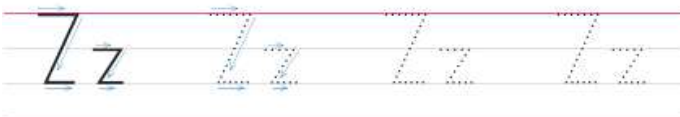

- Follow the procedure as suggested in lesson 15, 'Write'.

Homework

- Draw a picture of a zebra using the letter Z.

Lesson 70

Zz

In this lesson, there are six topics to cover:

1. Read (Reading)
2. Look and say (Listening, speaking and reading)
3. Write (Writing)
4. Read (Reading)
5. Read and discuss (Reading)
6. Copy (Writing)

Objectives:

- Read the letters: a, b, c, d, e, f, g, h, i, j, k, l, m, n, o, p, q, r, s, t, u, v, w, x, y and z.
- Say the words that have 'z' in initial position.
- Read the words correctly.
- Read the text correctly.
- Trace and write the letters 'Z' and 'z'.

Materials:

- Letter cards (a -z)
- Pictures and word cards (zebra, zero and zoo; highlighting the initial letter 'z'.)

Before you teach:

1. Study the workbook thoroughly.
2. Have the materials ready.

1. Read

5 minutes

Read.

Z **V** **Y** **W** **X**

letter on the card.

- If they can't, read yourself and ask them to follow you.

- Show the letter cards one by one and ask the students to read the

2. Look and say

15 minutes

Look and say.

Zz



- Follow the procedure suggested in 'Lesson 16, Look and say'.

3. Write

10 minutes

- Follow the procedure as suggested in 'Lesson 15, Write'.

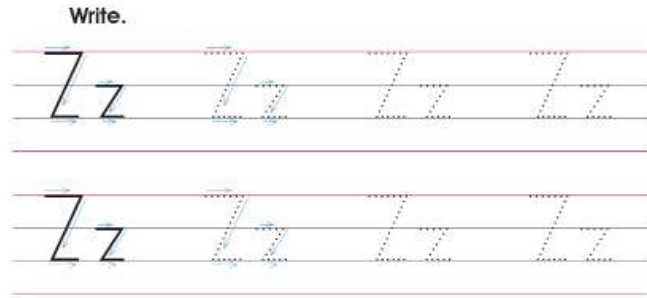

4. Read

10 minutes

- Follow the procedure suggested in 'Lesson 24, Read'.

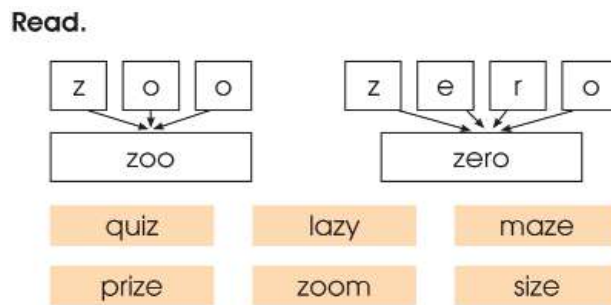

5. Read and discuss

- Follow the procedure suggested in 'Lesson 49, Read and discuss'.

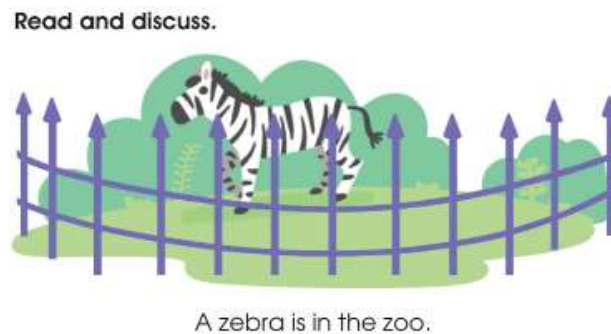

6. Copy

10 minutes

- Follow the procedure as suggested in 'Lesson 16, Copy'.

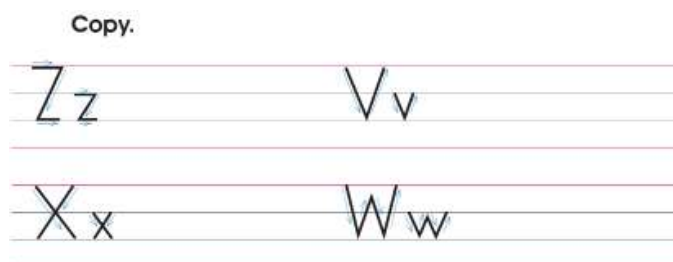

Homework

- Write the letters Aa - Zz.

Lesson 71

Uu - Zz

In this lesson, there are five topics to cover:

1. Read (Reading)
2. Circle the correct words for reading (Listening, speaking and reading)
3. Match. (Reading)
4. Find the words (Reading)
5. Write a -z (Writing)

Objectives:

- Read words.
- Discriminate sounds.
- Match the picture with its name.
- Blend onset with rime.

Materials:

- Alphabet cards (a-z)
- Word cards (zero, zoo, quiz, prize)

Before you teach:

1. Study the workbook thoroughly.
2. Have the materials ready.

1. Read

10 minutes

- Show the word cards one by one and ^{Read.} ask the students to read the words. **zero** **zoo** **quiz** **prize**
- If they can't, read yourself and ask them to follow you.

2. Circle the correct word for pictures.

10 minutes

- Ask the students to look at the pictures and name them. **Circle** (the correct word for pictures).
- Help them if they can't.
- Once they learn the name, ask them to read the words given with each picture.
- Tell them that they have to circle the word that names the picture.
- Now ask them to do the task.
- Move around the class and help them while they are doing the task.



- After they complete, check it thoroughly.

3. Match 10 minutes

Match.

- umbrella
- vase
- watch
- x-ray
- yak
- zebra



- Ask the students to read the words in the first column.
- Then ask the students to look at the pictures in the next column and name the pictures.
- Now, ask the students to match the words with the pictures.
- Tell them to do the task individually.

4. Find 10 minutes

Find.



E	D	L	Z	A	U	B	B
L	C	E	J	D	D	O	O
P	R	B	I	U	H	X	Y
Z	O	M	S	C	A	V	E
Z	W	A	I	K	L	M	H
Q	B	R	A	S	Z	O	O



- Ask the students to look at the picture.
- Ask them to name the picture.
- Tell them to find the name of the picture in the box.

- Once they find it, ask them to circle the word.
- Repeat the similar procedure for other pictures too.

5. Write a-z 20 minutes

Write a-z.

.....ppleallatogyean
.....ateenronokeriteeaf
.....onkeyestrangearrotueenabbit
.....nakeablembrellaanatchray
.....akebra				

- Follow the procedure suggested in 'Lesson 36, Look and write'.

Homework

- Write the letters a -z.

Lesson 72

Aa - Zz

In this lesson, there are four topics to cover:

1. Listen and say (Listening and speaking)
2. Play (Listening, speaking and reading)
3. Read (Reading)
4. Write A -Z (Writing)

Objectives:

- Read words.
- Say letters and the words.
- Blend onset with rime.

Materials:

- Word cards (eraser, sharpener, bench and prize)
- Snake and ladder board like the one given in the book.
- Dice and counters
- Alphabet chart
- Alphabet cards (a-z)

Before you teach:

1. Study the workbook thoroughly.
2. Have the materials ready.

1. Listen and say

5 minutes

Listen and say.

eraser sharpener bench prize

- Show the word cards one by one and ask the students to read the words.
- If they can't, read yourself and ask them to follow you.

2. Play

30 minutes

- Ask each player to put their counter on the space that says 'start here'.
- Ask them to take it in turns to roll the dice. Tell them to move their counters forward the number of spaces shown on the dice.
- If their counter lands at the bottom of a ladder, they can move up to the top of the ladder.
- If their counter lands on the head of a snake, they must slide down to the bottom

of the snake.

- The first player to get to the space that says 'finish' is the winner.
- Ask the students to read the alphabets and name the picture each time they move their counters.

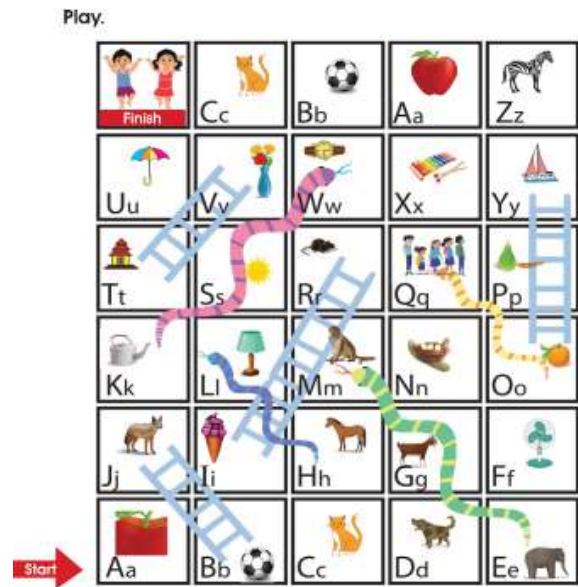

3. Read 10 minutes

- Display the chart and ask the students to read the alphabet.
- Help them read, if they find any difficulty.
- Divide the class into small groups (4/5 students) and ask them to read.
- Ask individual students to read the alphabets.

Read

Aa	Bb	Cc	Dd	Ee	Ff
Gg	Hh	Ii	Jj	Kk	Ll
Mm	Nn	Oo	Pp	Qq	Rr
Ss	Tt	Uu	Vv	Ww	Xx
Yy	Zz				

4. Write A- Z 15 minutes

- Follow the procedure suggested in 'Lesson36, Look and write'.

Write A - Z.

NT	AG	 ...ARROT	UCK	AR	ROG
OAT	 ...OUSE	 ...CE CREAM	 ...ACKAL	EY	 ...AMP
OUSE	OSE	 ...WL	EN	UILL	ADISH
 ...UN	AP	NICORN	ASE	ELL	EROX
AK	ERO				

Homework

- Write the letters A -Z.

ASSESS YOURSELF 2

Listen, point and say.

Bb	Ss	Mm	Aa	Uu	Cc
Kk	Nn	Vv	Ww	Tt	Ff
Pp	Ee	Jj	Oo	Gg	Hh
Xx	Ll	Ii	Rr	Yy	Qq
Zz	Dd				

Listen and point.

Carrot	Yak	Rose	Vase	Lamp
Ice-cream	Duck	Frog	Sun	Radish
Wolf	Owl	Well	Rabbit	Monkey
Kettle	Horse	Cab	Elephant	Xerox

Match the words with pictures.



- Leaf
- Vase
- Nest
- Goat

Read the words.

toy	yellow	taxi	water	crow
cab	train	queen	doll	lion
hen	meal	jackal	beak	ghee
ink	dice	child	high	hat

Write from **Aa** to **Zz**.

This is the assessment section of the theme. The tasks given in the workbook are for this theme. Do it in class.

- Do this task individually. You say each letter, the students point at it. Listen to the pronunciation and observe.
- Do this task individually. You say each letter, the students point at it. Listen to the pronunciation and observe.
- Repeat the procedure suggested in 'Lesson 71, Match'.
- Students do this task individually.
- Ask the students to read the words in the table one by one.
- Do this task individually.
- Ask the students to write from Aa to Zz.
- Check their work.

TASKS for Continuous Assessment

The following are the sample tasks for continuous assessment for this theme. Administer the task and record the student's learning.

1. Provide letter cards to the students and pronounce the sounds /d/, /i/, /m/, /r/, /s/, /k/, /o/. Ask the students to pick up the card that matches the sound.
2. Give a set of words to the students: pin, bin, rat, mat, fat, goat, coat. Read the words one by one. Ask the students to identify and show the words.
3. With the same cards, read the words and ask the students to put the cards together which have rhyming words.
4. Hand them a set of pictures (apple, elephant, man, snake, truck). Ask them to name the pictures orally.
5. Show it to the students and ask them to make words orally.

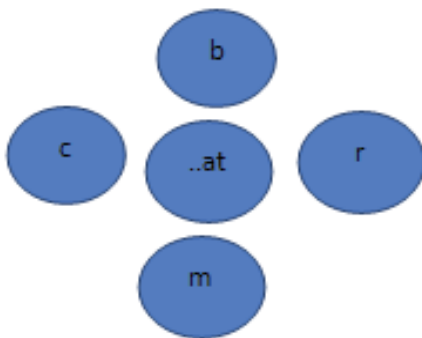

6. Sing the following chant and ask the students to follow you.
7. C for cat k k cat.
8. C for cup k k cup.
9. C for cock k k cock.
10. Provide an alphabet chart with both small and capital letters. Point to a particular letter and ask the students to read it.
11. Ask students to write from a-z and A-Z.
12. Ask the students to read the following sentence:
13. This is a ball.
14. It is a bird.
15. He is a boy.

If there are students who get 1 or 2 in this assessment, organize a remedial teaching and administer the assessment using the same tasks and record forms kept in the students' portfolio.

Lesson 73

Head and Shoulders

In this lesson, there are three topics to cover:

1. Look and read (Listening and speaking)
2. Sing and act (Listening, speaking and reading)
3. Read and write (Reading)
4. Look and complete the sentences (Writing)

Objectives:

- Name and recognize the parts of human body.
- Sing a rhyme with actions.
- Read a very short text and answer the questions.
- Complete the sentences with correct words by looking at the pictures.

Materials:

pictures, word cards

Before you teach:

1. Study the workbook thoroughly.
2. Have the materials ready.
3. Learn to sing the rhyme (<https://www.youtube.com/watch?v=jHfwxsGO904>)

1. Look and read.

20 minutes

Activity 1

- Greet them by saying ‘Good morning/afternoon class.
- Show them the parts of your body (given on the left) and ask the question: What is it? (by pointing to head, hand, stomach and leg)
- Ask question in whole group, in small group and individually.
- Do not give your answer yourself. Encourage them to come up with the answers. Let them use their language, if needed and translate their words into English.

Look and read.

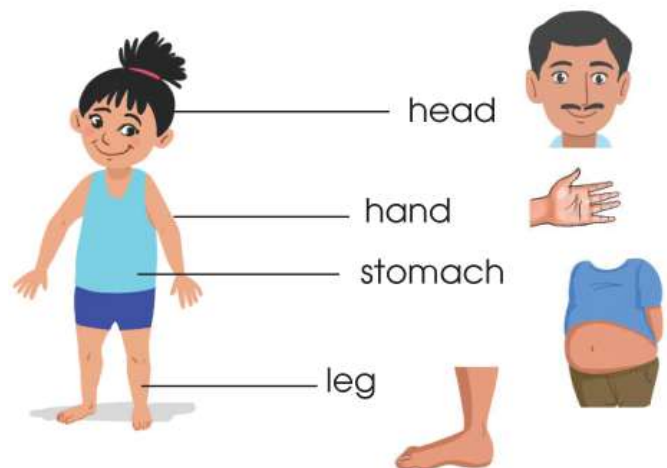

- Ask them to look at you. Touch the parts of your body telling their names.
- Ask the students follow you.

Activity 2

- Show them each picture (head, hand, stomach and leg) and ask them what that is.
- Say yourself and ask them to follow you.

Activity 3

- Now, show each of the word cards(head, hand, stomach and leg) and ask the students to read the word.
- Ask them to point out the part as they read a particular word.

Activity 4

- Call two students in front of the class.
- One of them touches the parts of his/her body and the other says its name.
- Ask them to take turns.
- Now ask the students to do the similar activity in pairs.

2. Sing and act 20 minutes

Sing and act.
 Head and shoulder,
 knees and toes,
 knees and toes.
 Head and shoulder,
 knees and toes.
 And eyes and ears
 and mouth and nose.
 Head and shoulders,
 knees and toes
 knees and toes.



- Follow the procedure suggested in lesson 1 'Listen and sing'.

3. Read and write

Read and write.

The Doll

This is my doll.
 The doll has a head.
 The doll has two hands.



- This is my _____
 a. doll b. ball c. book
- The doll has a _____
 a. nose b. head c. neck
- The doll has two _____
 a. legs b. ears c. hands

Activity 1

- Show the picture given in the book and ask: What do you see in the picture?
- Collect answers from the students (doll, girl, etc.). Let everyone say their answers.
- Ask: What does the doll

have? (Ask all the students to say their answers.) Elicit 'head, hands, etc.' from the students.

- Read the text at normal speed when the students point to the words in the text.
- Read the text and ask the students to follow you. When they follow, they point to the text with their fingers.
- Divide the students in pair where one reads and another follows. Ask them to swap the roles. Monitor and help the students to pronounce the words correctly.
- Ask the students to read the text individually and monitor.

Activity 2

- Ask the students to look at the questions: 1-3. Read the questions for them.
- Ask the students to tick the correct answers from 1-3 in their book by reading the text. Ask them to do it individually.
- Pair up the students and ask them to check each other's answers.
- Check the answers in whole group.

4. Look and complete the sentences 20 minutes

Activity 1

- Ask the students to look at the picture.
- Tell them to share the things they see in the picture.
- Do not say the answer yourself. Encourage everyone to speak.
- Now, show the picture (at the bottom) one by one and ask them to come up with the correct words for the blanks.
- Move around the class showing the picture with the book in your hands and elicit the words from each student. If they make wrong pronunciation, drill the words.
- Ask them to complete the sentences with the correct words.
- Make sure that they write the words correctly in the given space.

Look and complete the sentences.



1. There is a _____

2. There is a _____ on the tree.

3. There are _____ in the nest.



Homework

- Draw pictures of a hand and a leg.

Lesson 74

I See with My Eyes

In this lesson, there are three topics to cover:

1. Look and read (Listening and speaking)
2. Read and write (Reading)
3. Write the functions of the sense organs
4. Look and write three sentences (Writing)

Objectives:

- name and recognize the sense organs.
- sing a rhyme with actions.
- say the functions of the sense organs.
- complete the sentences with correct words by looking at the pictures.

Materials:

pictures, word cards

Before you teach:

1. Study the workbook thoroughly.
2. Have the materials ready.

1. Look and read.

20 minutes

Activity 1

- Greet them by saying 'Good morning/afternoon class'.
- Show them the pictures of sense organs (given on the left) and ask the question: What is it? (by showing eye, nose, ear, tongue and skin)

Look and read.

We have five senses. These are our sense organs.



eye

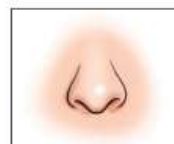

nose



ear



- Ask each question in whole group, in small group and individually.
- Do not give your answer yourself. Encourage them to come up with the answers. Let them speak their own language and translate their words into English.
- Ask them to look at you. Show your sense organs telling their names.
- Ask the students follow you.

Activity 2

- Show them each picture (eye, nose, ear, tongue and skin) and ask them what that is.
- Say yourself and ask them to follow you.

Activity 3

- Now, show each of the word cards (eye, nose, ear, tongue and skin) and ask the students to read the words.
- Ask them to show the organs as they read the words.

Activity 4

- Show the pictures one by one and elicit the words: see, smell, listen, taste and feel.
- Do not say the words yourself.
- Act out and ask the students to come up with the sense organs.
- Drill the sentences.
- Ask the students to say and act out the sentences.
- Divide the students in pairs and ask them to act out while they say the sentences. Ask them to swap the roles. Monitor and help the needy students.
- Show the pictures randomly and ask them to say the sentences. Do it in whole group, small group and individually.
- Say the words (eyes, nose, ears, tongue and skin) one by one and ask them to write the functions of the organs.

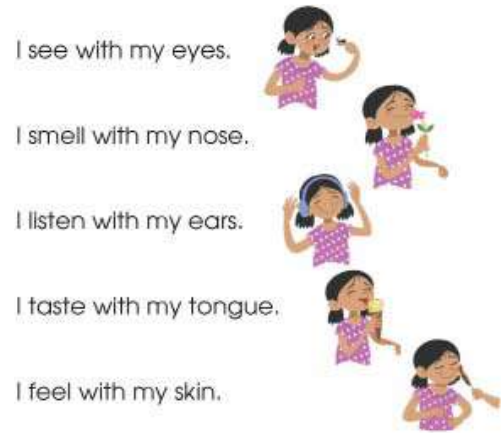

2. Read and write

20 minutes

Activity 1

- Show the picture given in the book and ask: What do you see in the picture?
- Collect answers from the students (tree, a mango tree, mangoes, etc.). Let everyone say their answers.
- Ask them about the colour and size of the picture.
- Read the text at normal speed when

Read and write.

Mango Tree

This is a mango tree.

It is big. It is green.

1. This is a mango

a. gift b. tree c. light

2. It is

a. small b. long c. big

3. It is

a. green b. red c. black



the students point to the words in the text.

- Read the text and ask the students to follow you. When they follow, they point to the text with their fingers.
- Divide the students in pairs where one reads and another follows. Ask them to swap the roles. Monitor and help the students to pronounce the words correctly.
- Ask the students to read the text individually and monitor.

Activity 2

- Ask the students to look at the questions: 1-3. Read the questions for them.
- Ask the students to tick the correct answers from 1-3 in their book by reading the text. Ask them to do it individually.
- Pair up the students and ask them to check each other's answers.
- Check the answers in whole group.

3. Write the functions of the given sense organs. 10 minutes

Activity 1

- Show the pictures to the students and ask them to name the pictures.
- Ask them the functions of each sense organ.
- Ask them to write the functions of each sense organ in the space given just below the pictures. Ask them to do it individually.
- Check the answers in whole group.

Write the functions of the given sense organs.



4. Look and write three sentences. 10 minutes

Activity 1

- Ask the students to look at the picture.
- Tell them to share the things they see in the picture.
- Do not say the answer yourself. Encourage everyone to speak.
- Now, show the picture (at the bottom) one by one and ask them to come up with the correct words for the blanks.

Look and write three sentences.



1. It is a _____

2. It has a long _____

3. It has two _____



- Move around the class showing the picture in your hands and elicit the words from each student. If they make wrong pronunciation, drill the words.
- Ask them to complete the sentences with the correct words.
- Make sure that they write the words correctly in the given space.

Homework

- Write the functions of the five sense organs.

TASKS for Continuous Assessment (Me and My Family)

The following are the sample tasks for continuous assessment for this theme. Administer the task and record the student's learning.

1. The teacher produces sound of animals and objects (dog, cow, cat, bell) asks the students to identify the animals or objects.
2. The teacher says /s/, /j/, /t/ and the students make words sit.
3. The teacher asks the students the following questions and asks them to answer
 - What is your name?
 - How many members are there in your family?
 - What's your father's name? etc.
4. The teacher reads the words: father, mother, family, head, hand, leg etc. and asks the students to repeat after him/her.
5. The teacher asks the students to sing the chant (workbook, lesson 73) after him/her.
6. The teacher asks the students to read the following sentences.
 - I see with my eyes.
 - I smell with my nose.
 - I listen with my ears.
7. The teacher shows the pictures of eye, ear, nose, tongue, skin etc. and asks them to name them.
8. The teacher asks the students to read the text from page lesson 73 of the workbook (The Doll) and asks the following questions:
 - Show the head of the doll.
 - Show the hands of the doll.
9. The teacher asks the students to trace different types of lines: straight, slant, curved etc.
8. The teacher asks the students to write the text of task 8 above.

If there are students who get 1 or 2 in this assessment, organize a remedial teaching and

administer the assessment using the same tasks and record forms kept in the students' portfolio.

Theme: My Daily Life

The theme 'My Daily Life' relates the language to real life situations. This theme is expected to help the students talk about the days of the week, express their ability and inability and tell the time in English.

Number of Lessons: 5

Lesson Topics

1. Brush Your Teeth (Lesson 75)
2. I can Jump (Lesson 76)
3. I'm Happy (Lesson 77)
4. It's Seven O'clock (Lesson 78)
5. Seven Days (Lesson 79)

Soft skills

- Time management
- Managing daily life
- Self-discipline
- Self-management
- Team work
- Communication
- Self-awareness
- Taking care of self

Language function

- Talking about days of the week
- Expressing ability
- Telling the time

Skill-wise objectives

Listening

- Recognize, identify and produce rhyming words. (e.g. cat → bat, sat)
- Match spoken words to printed words (e.g. the teacher pronounces /pin/, and the student selects pin from a set of three word cards).
- Recognize and comprehend words and simple expressions.
- Respond to the audio or the teacher non-verbally and verbally.

- Perform different kinds of listening tasks (e.g. drawing, matching, etc.).

Speaking

- Imitate and produce sounds and words.
- Pronounce grade appropriate words correctly.
- Ask and answer short, simple questions.
- Sing or recite a song/chant by listening to the teacher or an audio.

Reading

- Put sounds together to read words and sentences.
- Recognize and read familiar words accompanied by visuals.
- Perform rhymes and chants with appropriate rhyme and rhythm.
- Understand the meaning of grade appropriate words.
- Read words, simple sentences and short paragraphs correctly.

Writing

- Use correct spelling of the words.
- Write simple phrases and sentences independently.
- Demonstrate good handwriting skills.

Lesson 75

Brush Your Teeth

In this lesson, there are three topics to cover:

1. Look and read (Listening and speaking)
2. Read and write (Reading)
3. Complete the sentences (Writing)

Objectives:

- Listen to action words and act them.
- Talk using action words.
- Understand and write action verbs with correct spelling.
- Read a very short text and answer the questions orally.
- Complete the sentences with correct words by looking at the pictures.

Materials:

pictures, sentence cards, word cards.

Before you teach:

1. Study the workbook thoroughly.
2. Have the materials ready.

1. Look and read.

20 minutes

Look and read.



Wash your face.
Brush your teeth.
Comb your hair.
Cut your nail.

Activity 1

- Greet them by saying ‘Good morning/afternoon class’ and get back the response.
- Show them the picture (given on the left) and ask the question: What is it? (by pointing to the rabbit, mirror, brush, sink etc.) Where is the rabbit? (in



bathroom), What is he doing? (brush his teeth).

- Ask each question in whole group, in small group and individually.
- Do not give the answer yourself. Encourage them to come up with the answers. Let them speak their own language and translate their words into English.
- Ask them to look at you while you act brushing your own teeth.
- Ask them to act out 'brush your teeth'.

Activity 2

- Ask them to close their book.
- Read the given sentences one by one and ask them to look at and listen to you: Wash your face. Brush your teeth. Comb your hair. Cut your nail. Repeat each sentence 4/5 times. When you read, act out the verbs.
- Read the sentences given one by one and ask them to follow you. Do this many times so that they can repeat correctly after you. Do this in whole group first, in small group and individually.
- Ask them to open their book. Ask them to show the sentences in their book and read with you together.
- Ask the students to point and read the sentences themselves.

Complete the sentences.

1. Wash your _____ 
2. Brush your _____ 
3. Comb your _____ 
4. Wear your _____ 

Activity 3

- Write the words on the board (wash, brush, comb, cut), act out the verbs. After that ask them to act out the action verbs after you read each word.
- Act out each verb randomly and ask them to say the correct verb for your act.
- Write the complete sentences on the board as given in the book and act again.
- Read the complete sentences and ask the students to act out the verbs themselves.
- Teach the meaning of other words: face, teeth, hair, nail (showing by yourself).
- Now, read the sentences one by one and ask them to act out. (You say: wash your face and the students act out washing their face). Do this in order of the sentences first and then randomly later. Do this first in whole group and in pair (one says and another act) and individually at the end.

Activity 4

- Show the pictures one by one and elicit the words: wash, hand, eat, food, drink, water, clean, plates.
- Do not say the words yourself.
- Act out 'wash hands, eat food, drink water, clean plates' and ask the students to come up with the sentences.
- Drill the sentences.
- Ask the students to say and act out the sentences: wash your hand, eat food, drink

water, clean plates.

- Divide the students in pairs and ask them to act out and say the sentences. Ask them to swap the roles. Monitor and help the needy students.
- Show the pictures randomly and ask them to say the sentences. Do it in whole group, small group and individually.
- Say the following words one by one and ask them to write the words in the air: wash, brush, comb, wear, clean, drink, eat, face, teeth, hair, nail, hand, food, water, plates.

Activity 5

- Write the words on the board. Ask the students to stand in two rows. You read a word and one student from each row runs to the board to point. One who touches the word first gets a point. Make sure that, they don't hurt themselves while running.
- Erase the words from the board. Ask the students to say as many words as they remember.

2. Read and write

20 minutes

Activity 1

- Show the picture given in the book and ask: What do you see in the picture?
- Collect answers from the students (frog, pond, plants). Let everyone say their answers.
- Ask: What does a frog eat? (Ask all the students to say their answers.) Elicit 'fly' from the students.
- Read the text at normal speed when the students point to the words in the text.
- Read the text and ask the students to follow you. When they follow, they point to the text with their fingers.
- Divide the students in pair where one reads and another follows. Ask them to swap the roles. Monitor and help the students to pronounce the words correctly.
- Ask the students to read the text individually and monitor.

Read and write.

Frog

I see a frog.

The frog is in a pond.

The frog eats a fly.



1. What do I see?

a cat

a frog

a bee

2. Where is the frog?

in a pond

on the ground

on the leaf

3. What does the frog eat?

a bee

an ant

a fly

Activity 2

- Ask the students to look at the questions: 1-3. Read the questions for them.
- Show the pictures of cat, bee, pond, ground, leaf, ant and fly one by one and

pronounce the words correctly and ask them to repeat after you. (Repeat words 5/6 times)

- Show the pictures one by one again and ask them to say what it is. Write the words on the board one by one on the board.
- Say the words one by one (not showing the words) and ask them to spell the words.
- Say the words one by one and ask students to write the words in their exercise book.
- Ask the students to tick the correct answers from 1-3 in their book by reading the text. Ask them to do it individually.
- Pair up the students and ask them to check each other's answers.
- Check the answers in whole group.

3. Complete the sentences

20 minutes

Activity 1

- Act out the following and ask students to guess what you are doing.

- wash hands
- brush teeth
- comb hair
- wear clothes

- Do not say the answer yourself. Encourage everyone to speak. Repeat the acting 4/5 times. Focus the weaker students.

- Now, show the picture one by one and ask them to come up with the correct words for the blanks.
- Move around the class showing the picture with the book in your hands and elicit the words from each student. If they make wrong pronunciation, drill the words.
- Ask them to complete the sentences with the correct words.
- Make sure that they write the words correctly in the given space.
- Remind them to use full stop at the end of each sentence.

Wash your hand.



Eat food.



Drink water.



Clean plates.



Lesson 76

I Can Jump

In this lesson, there are three topics to cover:

1. Look and read (Listening and speaking)
2. Read and write (Reading)
3. Write what you can and can't do (Writing)

Objectives:

- Identify the difference between can and can't.
- Use can and can't to express their inability both in spoken and written form.
- Read a short text and answer questions.

Materials:

pictures, rhyme chart, word cards.

Before you teach:

1. Study the workbook thoroughly.
2. Have the materials ready.

1. Look and Read.

20 minutes

Activity 1

- Sing the following chant with acting and ask them to listen to you first.

*I can jump and I can clap,
I can eat and drink,
But I can't drive and I can't fly.
What do you think?*

- Paste the rhyme chart on the wall or you can write the chant on the board, ask them to sing with you together.
- Invite the students to the front of the class and ask them to sing the chant with acting.
- Make sure that they are pronouncing the words correctly.

Activity 2

- Show the students the picture one by one and talk about the picture. What is it?

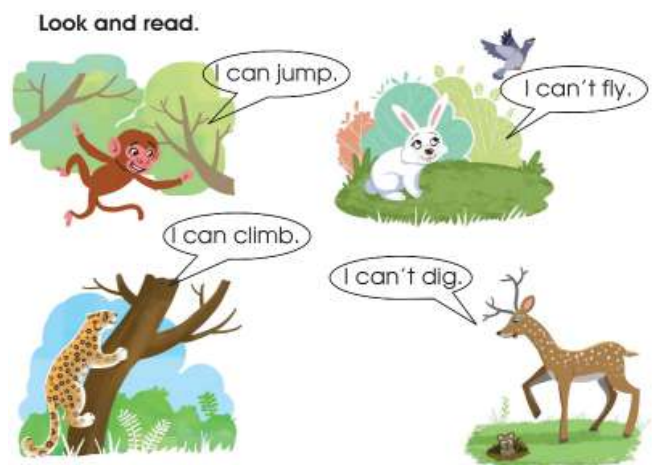

(Elicit monkey, rabbit, pigeon, cheetah, deer)

- Ask them what each animal can and can't do. Help them to say the sentences.
- Show each picture and drill the sentences: I can and I can't..... given in each picture. Do chorus drill and individual drill.
- Show the picture one by one and ask the students to read the sentence given for the picture. Do it in group first and individually later.

Activity 3

- Write tick mark (✓) on the left of the board and can below it and cross mark (X) on the right of the board and can't below it.
- Talk about what you can do and can't do. When you say can statement show to the tick mark side and when you say can't statement, show to the cross mark side.
- Ask the students to think what they can do and can't do. Show to the can side, they say can statement and show to the can't side, they say can't statement. Do it in group first and individually later.
- Divide the students into pairs. Ask them to take turns to say can and can't statements. Monitor and note any mistakes made. When they finish, correct the wrong pronunciation noticed during the monitoring.
- Ask them to look at the pictures given and talk about the picture one by one: Who is the boy? (Hari), What can he do? (He can sing.) What can he not do? (He can't dance.) Who is the girl? (Sunita), What can she do? (She can read.) What can she not do? (She can't draw.)
- Show one picture at a time. The students say the sentence.
- Divide the participants into pairs. Ask them to take turns to show the picture and say the sentence. Monitor and help if necessary.

Hari can sing.
He can't dance.



Sunita can read.
She can't draw.



2. Read and Write.

20 minutes

Activity 1

- Show the picture and ask questions: What is it? (monkey, tree, tail). What is he doing? (hanging) Do you like monkey? Why? Do you also climb tree? Encourage students to speak.

- Ask students: What can a monkey do? (Elicit: jump, climb, dance etc.) What can a monkey not do? (Elicit swim, read, write etc.) Encourage them to use complete sentences. E.g. It can jump. It cannot read.

Read and write.

The Monkey

This is a monkey.
It has a long tail.
It can jump.
It can't swim.



1. This is a _____
a. cat b. bird c. monkey



2. It has a long _____
a. tall b. ear c. nose



3. It can _____
a. sleep b. jump c. walk



- Read the text at natural speed and ask them to follow you by pointing the sentences with their fingers.
- Read the text and ask them to follow you. While doing this, read one sentence at a time not a word at a time.
- Divide the students in pairs. Ask them to read. One reads the text and another follows. Ask them to swap their roles. Monitor and help them if necessary.
- Ask them to read the questions 1-3 and look at the picture.
- Teach the meanings of any word if necessary.
- Ask them to choose the correct answers. When they finish, ask them to check their answers in pairs.

3. Write what you can and can't do. 20 minutes

Activity 1

- Ask the students to say the word for what you act. Act the following verbs and ask them to guess the words: walk, read, jump, fly, drive, cook.
- Write the words: walk, read, jump, fly, drive, cook. Teach them the correct pronunciation and spelling of the words.

Activity 2

- Put the word cards (walk, read, jump, fly, drive, cook) facing down.
- Students take turns to pick up the cards and say if he/she can or can't do the thing written on the card. E.g. a student picks up the card 'walk', reads the word and makes a sentence: I can walk.

Activity 3

- Ask the students to look at their book and ask them to complete the sentences with the verbs given.
- Move around the class and monitor.

 Write what you can and can't do.

I can _____		I can't _____
I can _____		I can't _____
I can _____		I can't _____
I can _____		I can't _____
I can _____		I can't _____
I can _____		I can't _____

walk read jump fly drive cook

Activity 3

- Put the word cards (walk, read, jump, fly, drive, sing, dance, write, climb) facing down.
- Students take turns to pick up the words (one student picks up one word only). They look at the card and act out and other students guess the words and write.
- When no cards left, teachers move around the class and check who has written all the words.
- The student who has all the correct words reads out the words and wins.

Lesson 77

I'm Happy

In this lesson, there are three topics to cover:

1. Look and read (Listening and speaking)
2. Read and write (Reading)
3. Look and write (Writing)

Objectives:

- Identify the words for different emotions like; happy, sad, angry etc.
- Read a short text and answer questions.
- Identify the words accompanied by visuals.

Materials:

pictures, rhyme chart, word cards.

Before you teach:

1. Study the workbook thoroughly.
2. Have the materials ready.
3. listen and watch the song <https://www.youtube.com/watch?v=tVlcKp3bWH8>

1. Look and Read.

30 minutes

Activity 1

- Sing this song to the students:
Hello! Hello! Hello! How are you?
Hello! Hello! Hello! How are you?
I'm good.
I'm great.
I'm wonderful.
I am good.
I'm great.
I'm wonderful.
Hello! Hello! Hello! How are you?
Hello! Hello! Hello! How are you?
I'm tired.
I'm hungry.

I'm not so good.

I'm tired.

I'm hungry.

I'm not so good.

Hello! Hello! Hello! How are you?

Hello! Hello! Hello! How are you?

Hello! Hello! Hello! How are you?

Hello! Hello! Hello! How are you?

Look and read.



- Once they learn the tune, paste the rhyme chart on the wall and sing it together.
- Encourage the students to sing the chant individually too.

Activity 2

- Show the pictures from the book one by one and say the words. Ask the students to say the words after you to help them learn the pronunciation of the words. Do it in group first and individually later.
- Ask the students to close their book. Show the picture from the book covering the words and ask students to guess the words for the pictures. Move around the class and repeat the activity with every student. When they say the words, ask them to write the words. Check if they have written the words correctly.
- Show the following pictures one by one and ask them to say the words for them.
- Do not say the words by yourself, encourage them to speak. Ask them to use their language if they can't but it should be the last option.
- When they say the words show the other side of the picture to show the words written on it. (happy, sad, crying, hurt)
- Help them learn the pronunciation through drilling.

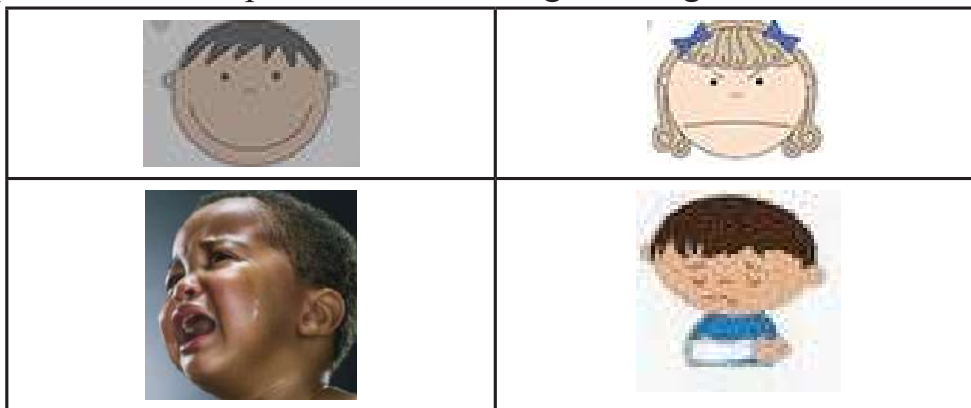

Activity 3

- Play an emotion walking game while outside. Ring a bell and have everyone walk around the playground like they are sad. Ring the bell again and have the children walk like they are happy. Repeat the activity until you have practised several emotions. (angry, crying, hurt etc.)

Activity 4

- Ask questions to the students about the pictures in their book: How many children are there? How many boys? How many girls?
- Pointing to each picture, ask: How is he/she?
- Let them guess the words themselves. Make sure that everyone is speaking.
- When they have correct guesses. Ask them to write the words in their workbook.
- Monitor around the class and check whether they are writing the words correctly. Help them if necessary.
- Ask them to look at each other's work.

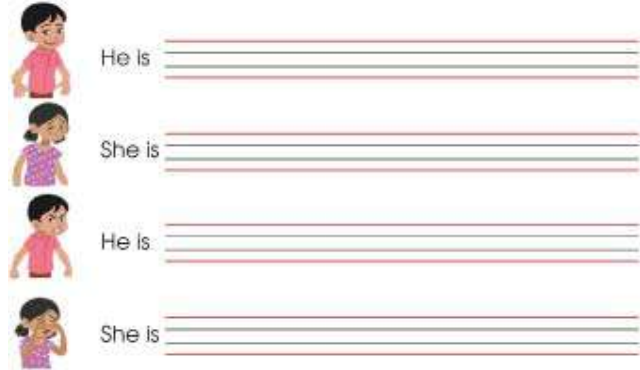

2. Read and write.

15 minutes

Activity 1

- Ask the students to look at the picture and ask the questions: What can you see? (A girl and a doll) What is the girl holding? (A doll) Do you have a doll? Do you play with the doll?
- Read the text at normal speed, the students point to the words while you read.
- Ask the students to read the text with you.
- Ask the students to read the text individually. Notice wrong pronunciation and make corrections as per the necessity.

Read and write.

The Doll Says, "Hello"

Sunita has a doll.
The doll says, "Hello".
Sunita is happy.



1. Sunita has a _____
a. book b. doll c. ball
2. The doll says _____
a. hello b. hi c. bye
3. Sunita is _____
a. sad b. happy c. angry

- Ask the students to read the text and find out the name of the girl. (Sunita)
- Ask the students to answer the questions: What does Sunita have? Who says hello? Is Sunita happy or sad?
- Ask the students to choose the correct answer for questions 1-3 and write them in the workbook.

3. Look and write.

15 minutes

Activity 1 (Hangman game)

- Ask the students to close their books.
- Write the words on the board as given in workbook one by one and the picture as given on the right.
- Divide the class into two groups.
- Decide the turn of the group.
- One tries to guess the missing letter for each blank.
- For the first incorrect guess, draw head from a noose on the gallows (the picture on the right).
- For each incorrect guess, another part of the person's body is drawn until you end up with a man hanging from a noose on the Gallows.
- Provide 4/5 chances to guess the letters for each word. If one group misses the chance to come up with correct words, the turn goes to another group.
- Repeat the same process with other words.

Look and write.

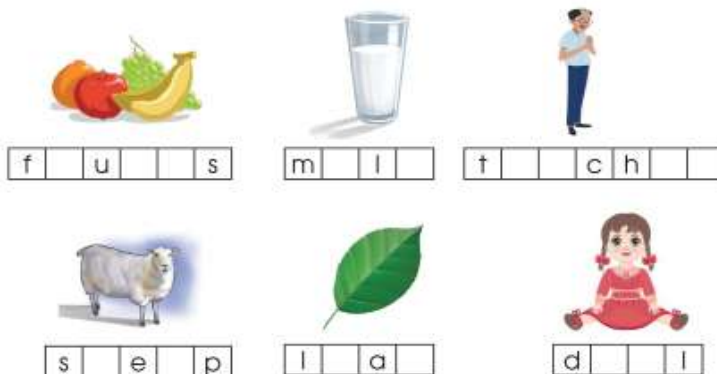

Activity 2

- Ask the students to open their books.
- Ask them to look at the pictures and supply the missing letters.
- Monitor around the class and help needy students but do not give the correct answer by yourself.

Homework

- Draw your picture with happy face. The next day, ask them to paste their pictures on the classroom wall.

Lesson 78

It's Seven O'clock

In this lesson, there are three topics to cover:

1. Look and read (Listening and speaking)
2. Read and write (Reading)
3. Look and write the time (Writing)

Objectives:

- Learn the clock to tell time.
- Read a short text and answer the comprehension questions.
- Write time correctly.

Materials:

clock model, rhyme chart, word cards.

Before you teach:

1. Study the workbook thoroughly.
2. Have the materials ready.
3. listen and watch the song <https://www.youtube.com/watch?v=BIImDM3xetYc>

1. Look and Read.

35 minutes

Activity 1

- Sing the song given and ask the students to listen to you. (Learn the tune from the YouTube link given above or try yourself.)
- Sing the song together with the students.
- Paste the song written on a chart on the wall and ask the students to sing the song.
- Make sure that they are pronouncing the numbers and 'o'clock' correctly.

Ticky ticky ticky tick-a-tick What time is it? One o'clock Two o'clock Three o'clock Tick-tock! Four o'clock Five o'clock Six o'clock Tick-tock! Seven o'clock Eight o'clock Nine o'clock Tick-tock! Ten o'clock Elevent o'clock Twelve o'clock	What time is it? Faster! One o'clock Two o'clock Three o'clock Four o'clock Four o'clock Five o'clock Six o'clock Tick-tock! Seven o'clock Eight o'clock Nine o'clock Tick-tock! Ten o'clock! Eleven o'clock Twelve o'clock
--	---

Activity 2

- Put the clock like the one on the left made beforehand on the wall.

- With the song still on the wall. Move the hour hand to one and minute hand to twelve and say 'It's one o'clock'. Do this with all the hours.
- Start from one o'clock by moving the hands to appropriate place and ask 'What time is it?' at every movement.



Activity 3

- Show the pictures of the clocks (one at a time) given in the workbook and ask question: What time is it?
- Do it in group first and individually later.
- Ask the students to read the first two sentences and find the name of the girl.
- Again show the clocks one by one and the picture. and ask: It is seven o'clock.

It's Seven O'clock

Look and read.

It is seven o'clock.
Bina gets up.



It is eight o'clock.
Bina eats her meal.



It is nine o'clock.
Bina goes to school.



It is ten o'clock.
Bina is in the classroom.



It is one o'clock.
Bina eats her snacks.



It is four o'clock.
Bina comes home.



What does Bina do?

- Help them learn the meaning of words: gets up, eats, meal, goes, snacks, comes etc. and drill the words for learning the correct pronunciation of the words.
- Divide the students in pairs. One shows the clock and the picture and ask questions: What time is it? What does Bina do? and another answers: It is seven o'clock. Bina gets up.
- When one finishes, ask them to change the role.
- Monitor around the class and help the needy ones.
- Ask one pair to come up to the front of

the class and tell them to act out the question answer.

2. Read and write.

15 minutes

Activity 1

- Ask them to look at the picture and ask them: What can you see in the picture? Elicit: clock, table, wall, room, floor etc.
- Ask: Where is the clock? (Elicit: The clock is on the wall.)

- Teach the words: wall, table, clock and floor. First show them in the picture and pronounce the words. Then, drill the words until all the students are able to pronounce the words correctly. Write the words on the board so that they learn the spelling of the words. Finally, ask them to write the words when you say them one by one.

Read and write.

Time

I am a clock.
I am on the wall.
I tell time.
Boys and girls look at me.



1. Who am I?
I am a _____
a. book b. clock c. time
2. I tell _____
a. time b. story c. song
3. I am on the _____
a. table b. floor c. wall

- Read the text given at normal speed. The students follow you by pointing to the text.
- Ask the students to read the text loudly.
- Divide the students into pairs and ask them to read. One reads, another follows by pointing to the line. Ask them to swap the role. Monitor and check if they are reading correctly.
- Ask the following questions orally: What is it? What does it tell? Where is the clock?
- Ask them to look at the questions in their workbook and choose and write the correct answers.
- When they finish, check their answers.





3. Look and write the time.

15 minutes

Activity 1

- Show different times in the model clock made by you and ask each time: What time is it now?
- Do this with all the hours (1-12) but randomly.
- Ask them to look at the workbook and ask them to look at the clock and write the time.
- Monitor and make sure that they are writing correctly.

Look and write the time.

 7 o'clock It is _____ _____	 1 o'clock It is _____ _____
 10 o'clock It is _____ _____	 4 o'clock It is _____ _____

Lesson 79

Seven Days

In this lesson, there are three topics to cover:

1. Look and sing (Listening and speaking)
2. Look and write the days in the correct order (Reading)
3. Complete the sentences (Writing)

Objectives:

- Learn the names of the days.

Materials:

Word cards (names of the days), bilingual (English and Nepali) calendar of a month.

Before you teach:

1. Study the workbook thoroughly.
2. Have the materials ready.
3. listen and watch the song <https://www.youtube.com/watch?v=MLs9OHSaYc>

1. Look and sing

30 minutes

Activity 1

- Talk about the pictures by asking the following questions to the students:
 - a. Pointing to each picture, ask the question: What do you see? Encourage the students speak in English. If they can't, accept the answers in their own language too but tell them the English words.
 - b. What is the mouse doing?
 - c. What is the elephant doing?
 - d. What is the deer doing?
 - e. What is the parrot doing?
 - f. What are the rabbit and the bear carrying?
 - g. Where are they going?
 - h. What is the building?
- Ask them the questions: Do you read books? Do you read balls? Do you play



skipping? Do you carry bags? Do you go to school? Encourage everyone to speak.

Activity 2

- Tell them that they are going to sing a song. Learn the tune of the song given in the workbook or make it your own tune.
- First, sing the song by yourself. Learn the pronunciation of the days of the week beforehand by consulting a dictionary.
- Now, ask them to sing with you.
- Ask them to sing the song in the group.
- Ask them to sing the song individually by pointing with their fingers.

Activity 3

- Tell them that you are going to play a song on your mobile <https://www.youtube.com/watch?v=MLs9OHSaqYc> or sing it yourself.
- Put the chart of the song below on the wall and help them sing together.

Every week has seven days.

Starting from Sunday.

Monday and Tuesday.

Did you brush your teeth today?

Wednesday and Thursday.

Did you wash your face today?

Friday and Saturday.

Eat your meals every day.

We come again to Sunday.

And then we go day by day. Ask the students sing the song first in group and then individually.

2. Look and write the days in the correct order. 15 minutes

Activity 1

- Ask the students to remember the names of the days from the song and note them down on the board.
- Translate the words into Nepali or into their language and help them learn the

equivalent names of the English days.

- Show them the calendar and ask them to say the name of the days when you point.

Activity 2

- Divide the students into seven groups. Give the students letter cards for each group so that they will be able to make a name of the days of a week. Tell them that it's a competition. Ask them to rearrange the letters to make words for the names of the days.
- In the same group, give a set of word cards (Sunday to Saturday) and ask them to put them in order of the days of the week.
- Collect the cards. Identify seven students and give one card to each student. They come to the front of the class and stand in a line facing to the class in the correct order of the days (from left to right).



Activity 3

- Ask them to look at their workbook and write the names of days in the workbook.
- Move around the class and check the spelling.

Complete the sentences.

Yesterday was _____
Today is _____
Tomorrow is _____



3. Complete the sentences.

15 minutes

Activity 1

- Show them this in their workbook.
- Show a day in your book and ask them to say the day. Do it with all the days.
- Ask them to say the names of the days in order.
- Make sure that everyone knows and says the answer.
- Ask the following questions showing the calendar of this month.
 - a. (Pointing to yesterday's date and day in the calendar) ask: What day was it yesterday?
 - b. (Pointing to today's and day in the calendar) ask: What day is today?

- c. (Pointing to tomorrow's date and day in the calendar) ask: What day is tomorrow?

Do this with as many students as possible. Explain the meaning of yesterday, today and tomorrow if they don't know.

- Then, ask the students to write the correct day in their workbook.
- Ask them to check each other's answers.

Homework: Prepare a chart for seven days of a week. Make it attractive.

ASSESS YOURSELF 3

This is the assessment section of the theme. The tasks given in the workbook are for this theme. Do it in class.

- Ask the students do this task individually. You say each sentence, the students repeat the sentences after you and act what is said in the sentence. Listen to the pronunciation and

Listen, say and act.

- a. I can jump.
- b. I can run.
- c. I can brush my teeth.
- d. I can comb my hair.
- e. I can drink water.

Look at the picture and say what he/she can and can't do.



Look and say the time.

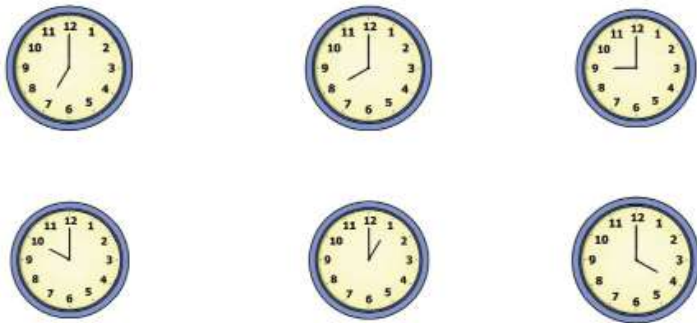

- observe.
- Ask the students do this task individually too. You point the picture and the students say: He can or can't for each picture. Listen to the answer carefully.
- Make the students do this task individually too. You point to the picture and ask: What time is it? The students say: It's o'clock. Listen to the answer carefully.

- Ask the students do this task in whole group.
- Ask the students open their book.
- Ask them to read the text, choose the correct answer and write them in the blanks.
- Check the students' work and provide feedback.

Read and answer.

I am a clock.

I am on the wall.

I tell time.

Boys and girls look at me.



1. Who am I?

I am a _____

a. book b. clock c. time

2. I tell _____

a. time b. story c. song

3. I am on the _____

a. table b. floor c. wall

Look and write the words.

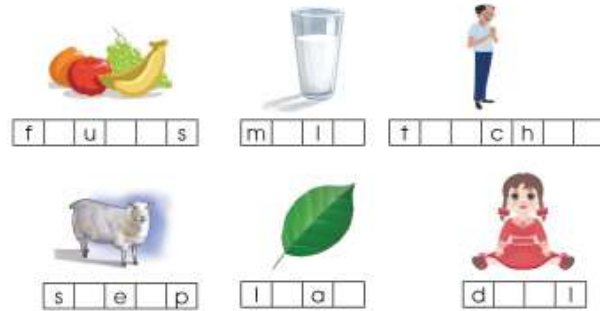

TASKS for Continuous Assessment (My Daily Life)

The following are the sample tasks for continuous assessment for this theme. Administer the task and record the student's learning in the record forms.

1. The teacher gives the students the rhyme from lesson 79, he/she reads the chant and the students underline the rhyming words.
2. The teacher gives the word cards clock, Sunday, classroom, come, eat etc. to the student, he/she reads the words and the student point the words spoken.
3. The teacher reads the text from lesson 76 (The monkey), and asks oral questions based on the text.
4. The teacher asks the following questions and the students answer orally.
 - What day is today?
 - What day is tomorrow?
 - What is the time now? (Show a clock)
 - Can you jump?
5. The teacher gives the students the reading text from lesson 77 (The doll says hello) and asks the students to read the text aloud and asks the following questions:
 - Who is happy?
 - Point Sunita in the picture? (Showing the picture)

6. The teacher gives the students the pictures of clocks showing different times and asks to write times in correct sentences.
7. The teacher asks the students to copy the text from the task 5 above.

You are required to assess the students' learning for two times. One is at the end of theme. Score in the record forms. If there are students who get 1 or 2 in this assessment, organize a remedial teaching and administer the assessment using the same tasks or different ones (you can develop them) and score in the record forms kept in the students' portfolio.

Theme: Our School

A learner interacts with friends, teachers and the things in school and builds knowledge independently. Learning of a child should be linked to his/her prior knowledge so that the learners will learn to talk about present action, give simple commands, ask for permission. They need to be able to talk about the things in school and their classroom. Similarly, they play different games and talk about them. They will develop phonemic and graphophonemic awareness along with learning to read fluently. They will also get involved in some comprehension tasks after reading a text. The soft skills like communication skill, team work and active listening will also be developed throughout the theme.

Number of Lessons: 5

Lesson Topics

1. Come here (Lesson 80)
2. May I ? (Lesson 81)
3. I'm Pawan (Lesson 82)
4. Things in the Classroom (Lesson 83)
5. Let's play (Lesson 84)

Soft skills

- Communication skills
- Team work
- Active listening
- Self-awareness

Language functions

- Talking about present action
- Giving simple commands

- Asking for permission

Skill-wise objectives

Listening

- Recognize and comprehend words and simple expressions.
- Respond to the audio or the teacher non-verbally and verbally.
- Respond to simple commands and questions.
- Perform different kinds of listening tasks (e.g. drawing, matching, etc.).

Speaking

- Imitate and produce sounds and words.
- Pronounce grade appropriate words correctly.
- Ask and answer short, simple questions.
- Sing or recite a song/chant by listening to the teacher or an audio.

Reading

- Put sounds together to read words and sentences.
- Recognize and read familiar words accompanied by visuals
- Perform rhymes and chants with appropriate rhyme and rhythm.
- Understand the meaning of grade appropriate words.
- Read words, simple sentences and short paragraphs correctly.
- Retrieve specific information from simple sentences.

Writing

- Write letters and words in a straight line from left to right with regular spacing between words.
- Copy letters and highly frequent familiar words and phrases correctly and reproduce them.
- Combine and recombine different letters to form words, and put the words in correct order to form simple sentences.
- Use correct spelling of the words.
- Write simple phrases and sentences independently.
- Give basic personal information in writing (e.g. name, address, age, nationality).
- Demonstrate good handwriting skills.

Lesson 80

Come Here

In this lesson, there are three topics to cover:

1. Look and read (Listening and speaking)
2. Read and write (Reading)
3. Match and write (Writing)

Objectives:

- Give simple commands.
- Read a short text and do comprehension task.
- Give and write simple commands.

Materials:

sentence cards (commands written on them), word cards.

Before you teach:

1. Study the workbook thoroughly.
2. Learn the pronunciation of words.
3. Have the materials ready.

1. Look and read.

40 minutes

Activity 1

- Show the students the pictures on the book and ask the following questions:
 - a. What do you see? (Elicit: a dog, a girl, a boy, a man, and the students)
 - b. What is the girl saying in the picture?
 - c. What is the boy saying in the picture?
 - d. What is the man saying in the picture?(Point to each picture while asking the questions)

Activity 2

- Teach the words (one at a time) following the given stages: come, here, go, there, sit down, look up, stand up, make, line, go out.
 - a. sound and meaning (demonstrate the meaning and pronounce the words)
 - b. repetition (drill the words)
 - c. written form (write the words on the board)
 - d. Example sentence (Give example from the workbook using the gestures)

Activity 3

- Read the speech bubbles given in the workbook while the students look at the picture and point to the sentence.
- Ask the students to read the speech bubbles together with you.
- Divide the students into pairs. Ask them to come to the front of the class. One says the sentences and another follows. Ask them to swap the roles.
- Monitor and check whether the students are saying the sentences correctly or not. Help them if necessary.



Activity 3

- Teach your students simple commands by playing a game of "Simon Says."
- Instruct them to do only what you ask if you say "Simon Says" before you give the directive.
- Start with simple instructions, such as "Simon Says jump two times" or "Simon Says touch your toes."
- Progress to commands you want your class to learn for safety or instructional purposes, such as "Simon Says point to the exit sign," "Simon Says face me" or "Simon Says raise your hands."
- Do this with as many instructions as possible.

Activity 4

- Before class, write down commands on pieces of paper — make sure that each sheet has a different command. Fold the pieces of paper (with commands written on them) and drop them into a bowl, basket or bag.
- In class, divide the class into two or three teams, depending on the size of your class. Write their team names on the board, as that's where you'll be keeping track of points.
- The teams should take turns sending one team member to the front of the room. When the student comes to the front, have them choose a command from your container. Without speaking or showing the paper to anyone else, the student must act out the command for their team to see. The team gets one minute to correctly guess the command. If the team guesses the correct command within one minute, award them one point. If a team doesn't guess the command in a minute, the slip of paper goes back into the bowl.

- Continue playing until all of the slips have been used.
- The team with the most points at the end of the game wins.

2. Read and write. 10 minutes

Activity 1

- Show them the picture and ask questions: Who are they? (a family) What are they doing? (sitting)
- Tell them: show me the father, show me the mother, show me the sister, show me the brother, one by one and move around the class to see if they are pointing to the correct person in the picture.
- Revise the words: father, mother, brother, sister and family. (They have already learnt these words in the past lessons)
- Ask them to look at the task 1-4. Ask them to write the correct words with the help of the pictures.
- Remind them to use full stop at the end of the sentences.
- Move around the class and check their work. If they have problem with the spelling, teach the spelling.

Read and write.

My Family

This is my father.
This is my mother.
This is my sister.
This is my brother.



1. This is my _____ 

2. This is my _____ 

3. This is my _____ 

4. This is my _____ 

3. Match and write. 10 minutes

Activity 1

- Write the words on pieces of paper (one word in each piece).
- Divide the students into three or four groups depending on the number of students.
- Give pieces of paper to each group.
- Ask them to work in groups and make up new words using two words from the pieces.
- Organize this as a competition.
- Ask each group to say their words.

Match and write.

Stand	there
Sit	here
Go	up
Come	down

_____	_____
_____	_____
_____	_____

Activity 2

- Ask them to look at their workbook and match the words by drawing lines.
- Move around the class and check their work.
- Ask them to write the words in the given spaces.

Lesson 81

May I ?

In this lesson, there are four topics to cover:

1. Look and read (Listening and speaking)
2. Read and practise (Listening and speaking)
3. Read and write (Reading)
4. Read and complete the sentences (Writing)

Objectives:

- Ask for permission using the structure: May I?.
- Give and deny permission using the structures: 'yes, you can' and 'no, you can't'.
- Read a short text and do comprehension task.
- Complete a very short dialogue.

Materials:

Prompt cards for permission, pictures

Before you teach:

1. Study the workbook thoroughly.
2. Learn the pronunciation of words.
3. Have the materials ready.

1. Look and read.

15 minutes

Activity 1

- Show them the picture from the workbook and ask: where are they? Why? Who is the woman? How many students are there?
- Encourage them to speak in English even if they come up with wrong structures.
- Show them the speech bubbles and ask: What are they doing? (saying something, asking for permission)



Activity 2

- Read the sentences by yourself while the students listen.

- Ask them to read the sentences together with you while they point to the book too.
- Write all the sentences on the board. Ask the whole class to read the sentences. Help them to use rising tone.
- Point to a particular sentence and ask one student to say the sentence.
- Do this with as many students as possible.
- Teach the word toilet following the stages: sound and meaning, repetition, written form and illustrative sentence.

2. Read and practise.

25 minutes

Activity 1

- Ask them to look at the pictures in the workbook.
- Read the sentences for them.
- Tell them that the sentences on the right are the answers.
- Ask them to repeat after you.
- Drill each sentence.

- Teach the words: play, television, watch, talk. Use the stages: sound and meaning, repetition, written form and example sentences.

- You say the first part one by one and students say the second part for each picture. Point to the picture each time.

Read and practice.



- Now, students ask the questions and you answer.
- Divide the students into pairs, they take turns to ask and answer.
- Monitor and help the students if necessary.

Activity 2

- Prepare the cards like this beforehand. You can just write the phrases.
- Cut the cards and put a tick or cross on the other side of each card.
- Give each student a card. On one side of the card is a permission prompt and on the other is a tick or cross.
- Students hold their card so the permission prompt is facing towards them and the

- tick or cross is facing away.
- Students then go around the class asking, giving and refusing permission with as many different partners as possible. (For this, write 'May I' 'Yes, you can' and 'No, you can't' on the board)
- If students see a tick, they give permission. If there is a cross, the students refuse permission.
- When the students have finished, they repeat the activity, but this time they hold their card the other way round so the permission prompt is facing away.
- The students then go around the class, asking permission to do different things each time they speak to a classmate.
- The students continue in this way until they have spoken to as many different partners as possible.



3. Read and write

15 minutes

Activity 1

- Ask the students to look at the picture and ask the questions: Who are they? What are they doing?
- Read the text by yourself at natural speed when the students follow you by pointing to the sentences.
- Ask the students to read the text together with you.
- Ask: What are the names of the children? Have them discuss. (the clues for identifying the names are: reading, writing, singing, dancing etc.)

Read and write.

What Are They Doing?

Roshan is reading.
 Preeti is writing.
 All is singing.
 Pasang is dancing.



- Roshan is _____
 a. writing b. dancing c. reading
- Preeti is _____
 a. writing b. singing c. dancing
- All is _____
 a. dancing b. singing c. writing
- Pasang is _____
 a. dancing b. singing c. reading

Activity 2

- Teach the words: writing, dancing, reading, singing. Act the meanings of the

words. Follow the stages: sound and meaning, repetition, written form and example sentence.

- Point to each picture and ask: What is he/she doing? Get the answers. Ask in whole group first and individually later.
- Ask the students to read and answer the questions. Ask them to choose the correct answer and write in the given space. Remind them to use full stop.
- Check their answers in whole group.

Activity 3

- Collect the pictures from newspaper or somewhere else where people are doing different things.
- Show the pictures one by one and ask: What is he/she doing? What are they doing?
- Write the structure: He/she is and They are
- Ask the questions first in whole group and then individually.
- Divide the students in pairs. They take turns to ask and answer. Show the pictures one by one, all the pairs ask and answer questions based on the picture.
- Help them learn the structures: is + v-ing and are + v-ing and meaning.

4. Read and complete the sentences. 5 minutes

Activity 1

Read and complete the sentences.

- Show the picture and ask: What do you see in the picture? Where are they going? What are they carrying? What is the boy saying? Why is he saying sorry? What did the girl say? Why?



1. Sarala : Ouch !
2. Sanad : _____
3. Sarala : _____

- Ask them to write the words in the given space. Remind them to use full stop and exclamation mark as given.

Lesson 82

I'm Pawan

In this lesson, there are four topics to cover:

1. Look and read (Listening and speaking)
2. Look and write who they are (Listening and speaking)
3. Read and write (Reading)
4. Look and write three words and complete the sentences (Writing)

Objectives:

- Introduce oneself using I'm....
- Read a short text and do comprehension task.
- Describe the actions happening at the time of speaking.
- Write simple sentences by looking at the pictures correctly.

Materials:

Self-introduction worksheet

Before you teach:

1. Study the workbook thoroughly.
2. Learn the pronunciation of words.
3. Have the materials ready.

1. Look and read.

10 minutes

Activity 1

- Show the picture and ask the questions: Where are they? Who are they? Who is the woman? How many students are there? What is the girl at the door carrying?
- Listen to the answers. Encourage the students speak.



Activity 2

- Ask the students to listen to you. Point to each student in the picture and say the sentence in the speech bubble. Learn the pronunciation of I'm (It's not I am its /a Im.
- Ask the students say the sentences together.
- Move around the class and check that they are saying the sentences correctly.

Activity 3

- Point to the pictures (one at a time) and move around the class and students says the sentence in the speech bubble.

2. Look and write who they are.

25 minutes

Activity 1

- Ask the students to look at the picture and say who they are.
- Elicit: father, mother, daughter and son.
- Ask them to write the words in the correct spaces. Remind them to use full stop.
- Point to the pictures (one at a time) and students say the sentence.
- Move around the class asking questions.

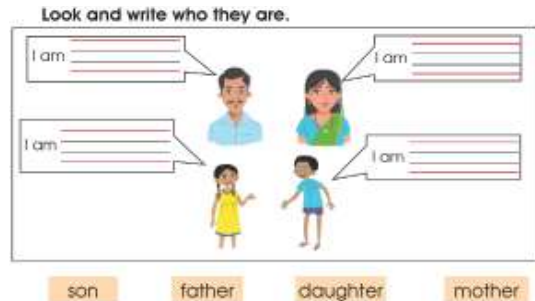

Hello. My name is _____ 

I am _____ years old. 

I live in _____ 

I go to _____ school. 

My parents are _____ 

My favorite food is _____ 

I like _____ 

Activity 2

- Give each student the worksheet on the left or write the questions on the board. (They don't have it in their book.)
- Ask them to complete the worksheet. Help them by asking questions: What's your name? How old are you? Where do you live? Which school do you go? What are your parents? What's your favourite food? What do you like?
- Introduce yourself using the template given. This way they will get idea what they need to say.
- Divide the students into pairs and ask them to take turns to introduce with each other.
- Invite as many students as possible to introduce themselves to the whole class using the clues in the worksheet.

3. Read and write.

20 minutes

Activity 1

- Show the students the picture and ask questions: Who is she? What is the girl doing? What is her name? How old is she? Which class does she read?
- Ask the students to read the text loudly to find out the name of the girl.
- Read the text loudly at normal speed for the students when they listen to you and point to the lines.

- Ask the questions from above and take answers orally.
- Ask the students to choose the correct answer and write in the workbook.
- When they finish, ask to compare their answers in pairs.

Read and write.

Hello Everyone!

Hello everyone!
I am Rita.
I am a girl.
I am five years old.
I read in class one.



- I am a _____
a. boy b. teacher c. girl
- I am _____ years old,
a. three b. five c. six
- I read in class _____
a. one b. two c. three

4. Look and write three words and complete the sentences. 15 minutes

Activity 1

- Show the picture and ask the questions: Who is she? What is she doing? What is she drinking? Is she standing or sitting? Where is she sitting?
- Collect the answers. Do not tell the answers by yourself. Repeat the questions until all the students say the correct answer.
- Ask them to write the words: girl, water, mat in the spaces given on the right of the picture.
- Ask them to complete the sentences given underneath the picture with the words they have listed.
- Move around the class and check their work.
- Ask them the questions: What is she doing? Elicit: She is drinking water. She is sitting on a mat.
- Tell them what you are doing at the real time: I'm teaching. I'm wearing a shirt. I'm holding a chalk.
- Ask what they are doing. Help them use 'am+v-ing', 'is+v-ing', 'are+v-ing'. Help them understand that we use these to talk about what is happening now.

Look and write three words and complete the sentences.



- _____
 - _____
 - _____
- She is a _____
 - She is drinking _____
 - She is sitting on a _____

Homework

- Write about yourself on a page with good and big handwriting with a picture of your own. (Tell them that the class will select the best one and give a prize for the winner.)

Lesson 83

Things in the Classroom

In this lesson, there are four topics to cover:

1. Look and read (Listening and speaking)
2. Match (Vocabulary)
3. Read and write (Reading)
4. Look at the family picture and complete the sentences (Writing)

Objectives:

- Talk about the things in the classroom.
- Read a short text and do comprehension task.
- Write simple sentences by looking at the pictures correctly.

Materials:

letter cards (as per the number of groups of students)

Before you teach:

1. Study the workbook thoroughly.
2. Learn the pronunciation of words.
3. Have the materials ready.

1. Look and read.

15 minutes

Activity 1

- Show the picture to the students and ask questions: What is the picture of? What do you see in the pictures? Elicit the words: classroom, whiteboard, rack, table, desk, bench, pencil, chair, guitar, toy, books etc.

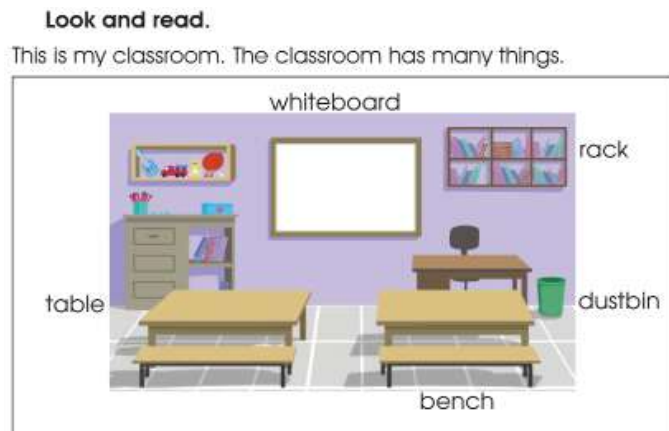

Activity 2

- Teach the words following the stages: sound and meaning, repetition, written form and illustrative sentence.
- Pronounce the words one by one by pointing to the picture so that they learn the meanings of the words.
- Drill the words in whole group first and individually later. (Learn the correct pronunciation of the words from a dictionary.)

- Then write the words on the board one by one. Point to one word at a time and ask students to pronounce the words.
- Clear the board and pronounce the words one by one and ask the students to write the words. This way, students learn the spelling of the words.
- Divide the class into three or four groups depending on the number of students: give a set of letter cards to each group so that they can make the words: whiteboard, desk, table, rack, bench, dustbin.
- Set the task as a competition.

2. Match

10 minutes

Activity 1

- Show the pictures one by one and ask the students: What is it?
- Ask them to write the words.
- Ask the students again: What do you do with it? (rack: I keep my shoes in it., table: I keep my bag on it., bench: I sit on it., whiteboard: I write on it.)
- Now ask the students to match the sentences with the pictures.

Match.

I sit on it.

I write on it.

I keep my bag on it.

I keep my shoes in it.



3. Read and write.

20 minutes

Activity 1

- Show the picture and ask students these questions: Who are they? Where are they? What are they doing? Where are they sitting?
- Elicit: They are students., They are in the classroom., One girl is drawing a picture., One boy is reading a book. They are talking. etc. Encourage them to speak as much as they can.
- Read the text at normal speed when the students follow you by pointing the lines in their book.
- Ask the students to read together with you.
- Ask the students to read the text aloud. Move around the class and notice the

Read and write.

My Classroom

This is my classroom.
There are many things here.
There is a table.
There are chairs.



1. Is this a classroom?

2. Is there a table?

3. Are there chairs?

pronunciation.

- If there's anything wrong with the pronunciation of words, drill the words to the whole class.
- Ask some questions orally to check their comprehension: Where are the chairs? Where is the table? (Elicit: table). Is there a table? (Elicit: yes, it is.)
- Ask the students to read the questions 1-3 and answer either 'yes, it is' or 'no, it isn't' by reading the text.
- Check the answers. Make sure that all the students have written correct answers.

4. Look at the family picture and complete the sentences. 15 minutes

Activity 1

Look at the family picture and complete the sentences.

- Show them the picture and ask the questions: Who are they? How many members are there? (Elicit: a family, five members)
- Point to each picture and ask: Who is this? (Elicit: father, mother, sister, brother, dog)



1. This is _____
2. This is _____
3. This is _____

- Then ask the students to read the sentences and complete them using the correct words according to the picture.
- Remind them to use full stop at the end of the sentences.
- Check the answers and make sure that they have written the words correctly.

Homework

- Draw a picture of your family. Tell them that the class will decide the best picture tomorrow and will get a prize.

Lesson 84

Let's Play

In this lesson, there are three topics to cover:

1. Look and read (Listening and speaking)
2. Read and write (Reading)
3. Look at the picture and write three sentences (Writing)

Objectives:

- Say what they like to play.
- Read a short text and do comprehension task.
- Write simple sentences by looking at the pictures correctly.

Materials:

Usual materials.

Before you teach:

- Study the workbook thoroughly.
- Learn the pronunciation of words.

1. Look and read.

30 minutes

Activity 1

- Show the picture to the students and ask questions: Where are the animals? What animals do you see in the picture? What objects do you see in the picture? (Elicit: in the jungle, monkey, rabbit, rat, parrot, deer, pigeon, elephant, football, volleyball, basketball, bat, swing, rope, cricket ball)

Activity 2

- Teach the words one by one: jungle, monkey, rabbit, rat, parrot, deer, pigeon, elephant, football, volleyball, basketball, bat, swing, rope, cricket, skipping.
- Follow the stages: sound and meaning (Pronounce the word and show the picture for meaning), repetition (drill the words until the students learn the correct

Look and read.

This is a jungle. There are many animals. They are playing games.



football

cricket

volleyball

skipping

swing

basketball

Which game do you like to play?

I like to play _____

pronunciation), written form (ask the students to write the words following your pronunciation) and illustrative sentence (ask them to make sentences using the words)

Activity 3

- Pointing to each picture: What is the (animal's/bird's name) doing? (Elicit: The monkey is playing the swing. The rat and rabbit are playing cricket. The deer is playing skipping. The elephant is playing volleyball. The parrot is playing basketball. The pigeon is playing football)

Activity 4

- Ask the students the question: Which game do you like to play? Do this first in group.
- Tell them your answer: I like to play football.
- Go to each student and ask: 'Which game do you like to play' and listen to the answer. Make sure that they use the correct structure: I like to play
- Divide the students in pairs. They take turns to ask and answer questions. Monitor and give feedback if necessary. Give them enough time to practise.

2. Read and write. 15 minutes

Activity 1

- Show the students the picture and ask: Where are they? How many children are there? How many boys are there? How many girls are there? What are they doing?
- Do not give the answers by yourself. Encourage them to speak.

Read and write.

The Playground

Juma has two friends.
Their names are Lakpa and Sonu.

They like to play on the swing.

They like to play in the playground.



1. Juma has _____ friends.
2. Their names are _____
3. They like to play _____
4. They like to play in the _____

Activity 2

- Tell them that they are going to read a text. Ask them to find the title of the text.
- Tell them that you are going to read the text aloud and they point to the lines while you read. (Learn the correct pronunciation of the words beforehand)
- Ask the students to read the text with you.
- Divide the students into pairs. Ask them to take turns to read the text. Monitor around the class and make sure that they are reading the text correctly.

Activity 3

- Ask them to read the text quickly and find out the names of the children.
- Ask these questions orally: How many friends does Juma have? What do they like to play? Where do they like to play?
- Wait for the answers.
- Ask the students to read the sentences given and find the answers from the text for the blanks.
- Ask them to write the answers in the spaces correctly. Remind them to use full stop at the end of each sentence.
- Ask them to check their answers in pairs.

3. Look at the picture and write three sentences. 15 minutes.

Activity 1

Look at the picture and write three sentences.

- Show the picture to the students ask questions: Where are they? What are they doing? (Elicit: They are in the playground. They are playing games.)



1. _____
2. _____
3. _____

Activity 2

- Point to each picture and ask: What are these children playing? (Elicit: They are playing cricket.) What are these children playing? (Elicit: They are playing football.)

Activity 3

- Ask the students to write three sentences individually about the picture in the given spaces.
- Encourage the students to be as creative as possible in writing sentences.

Possible sentences

- The children are in the playground.
- The playground is green.
- They are playing cricket.
- They are playing football.
- The girl is holding the bat.
- The cricket ball is in the air.
- The boy is running to catch the cricket ball.
- The boy is trying to kick the ball.

ASSESS YOURSELF 4

This is the assessment section of the theme. The tasks given in the workbook are for this theme. Do it in class.

Listen and follow:

- Come here.
- Sit down.
- Stand up.
- Make a line.
- Look up.

- Administer this task individually.
- Give commands and students follow.
- Do not follow the same order while giving commands to all the students.
- Observe to check whether the students have understood your commands.
- For the command (d. make a line), ask the students to be in group and check whether everyone understands your command.
- Divide the students into pairs.
- Ask them to ask questions to each other.
- They can respond (giving and denying permission.)
- Observe and see whether the students are asking questions correctly.
- Administer this task individually.
- Show the picture and ask questions: What is this picture of?
- What are the objects you can see?
- Give them clues to help them if necessary.
- Listen to them attentively and check whether they can name all the objects in the classroom.
- Administer this task in the whole class.
- Ask them to read the text loudly.
- Move around the class and check whether they are reading the text correctly at correct speed.
- Ask them to choose the correct answer and write in the correct space by reading the text.
- Check their work.
- Administer this task in the whole class too.
- Ask the students to look at the picture and write three sentences.

Ask and answer.



Talk about the things in the classroom.



Read and tick (✓) the answer.

Hello everyone!

I am Rita.

I am a girl.

I am five years old.

I read in class one.

1. Rita is a
a. boy b. teacher c. girl
2. She is years old.
a. three b. five c. six
3. She reads in class
a. one b. two c. three

- When they finish, check their work and provide feedback.

Look and write three sentences.



1. She is a _____
2. She is drinking _____
3. She is sitting on a _____

TASKS for Continuous Assessment (My School)

The following are the sample tasks for continuous assessment for this theme. Administer the task and record the student's learning.

1. The teacher reads the words : come, go, look, sit etc. and asks the students to write the words.
2. The teacher asks the students the following commands and questions and the students follows and give answers.
 - Come here.
 - Stand up.
 - Raise your hand.
3. Show the picture (lesson 81, what are they doing) and ask questions what they are doing.
4. The teacher gives the students the text (lesson 81, what are they doing) and ask the students to read the text aloud.
5. The teacher asks the students the following questions based on the text in task 4:
 - What is Roshan doing?
 - Who is writing?
 - What is Ali doing?
6. The teacher asks the students to copy the text of task 4 above.
7. The teacher gives the students lesson 82 (look and write three words and complete the sentences) and asks the students to write.

You are required to assess the students' learning for two times. One is at the end of theme. Score in the record forms. If there are students who get 1 or 2 in this assessment,

organize a remedial teaching and administer the assessment using the same tasks or different ones (you can develop them) and score in the record forms kept in the students' portfolio.

Theme: Our Environment

A child's surrounding is a great resource for learning. The theme 'Our Environment' utilizes the children's experience of their surroundings. They will be able to identify the things and talk about present actions. They will also learn the words related to the theme and prepositions to talk about the location, too. They will be familiar with different colours and flowers. Moreover, they will learn to use this and that in their day to day communication. The learners will learn communication skills, information management skills, respect for environment; and active listening skills.

Number of Lessons: 4

Lesson Topics

1. On the Table (Lesson 85)
2. The Rainbow (Lesson 86)
3. Red Rose (Lesson 87)
4. There is a Bag (Lesson 88)

Soft skills

- Information management
- Respect for the environment
- Respect for diversity
- Communication
- Active listening
- Responsibility
- Collaboration
- Team work

Language function

- Identifying
- Describing location
- Identifying colours
- Asking and answering 'Yes/No' and 'Wh' questions

Skill-wise learning outcomes

Listening

1. Match spoken words to printed words (e.g. the teacher pronounces /pin/, and the student selects pin from a set of three word cards).
2. Recognize and comprehend words and simple expressions.
3. Respond to the audio or the teacher non-verbally and verbally.
4. Perform different kinds of listening tasks (e.g. drawing, matching, etc.).

Speaking

1. Pronounce grade appropriate words correctly.
2. Ask and answer short, simple questions.
3. Sing or recite a song/chant by listening to the teacher or an audio.
4. Name people, objects and places and describe them with adjectives.

Reading

1. Put sounds together to read words and sentences.
2. Recognize and read familiar words accompanied by visuals
3. Perform rhymes and chants with appropriate rhyme and rhythm.
4. Understand the meaning of grade appropriate words.
5. Read words, simple sentences and short paragraphs correctly.
6. Retrieve specific information from simple sentences.
7. Do different kinds of comprehension tasks (answering verbally, matching, action, etc.)

Writing

1. Write letters and words in a straight line from left to right with regular spacing between words.
2. Copy letters and highly frequent familiar words and phrases correctly and reproduce them.
3. Combine and recombine different letters to form words, and put the words in correct order to form simple sentences.
4. Use correct spelling of the words.
5. Write simple phrases and sentences independently.
6. Demonstrate good handwriting skills.

Lesson 85

On the Table

In this lesson, there are five topics to cover:

1. Look and discuss (Listening and speaking)
2. Where is the cat? (Listening and speaking)
3. Read and write (Reading)
4. Colour the ball on the box (.....)
5. Look and write three sentences (Writing)

Objectives:

- Listen and talk about a picture related to location.
- Tell the location using 'on'.
- Read a very short text and do the task based on it.
- Colour the picture.
- Write sentences expressing the location based on the picture.

Materials:

pictures, sentence cards, word cards.

Before you teach:

1. Study the workbook thoroughly.

1. Look and discuss

20 minutes

On the Table

Look and discuss.

The bird is on the branch.
The girl is on the mat.
The frog is on the leaf.

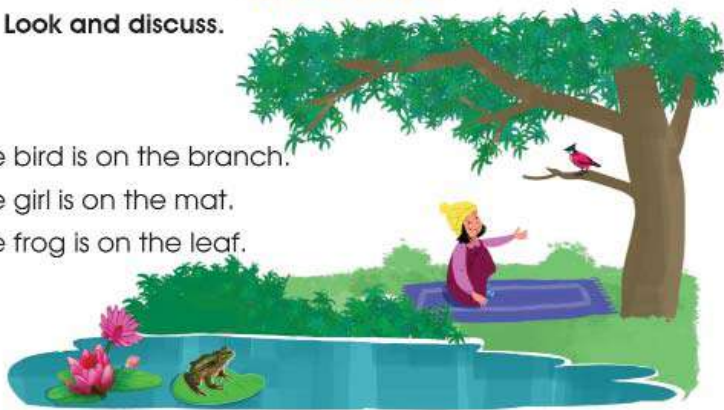

they see on the picture.

- After hearing students' ideas, tell them the theme of the lesson.

Activity 2

- Read the text carefully matching the sentence with the picture i.e. The bird

Activity 1

- Have students look closely at the picture of the workbook.
- Ask students to share what they think the picture might be about. Instruct students to look at the picture and point to/describe the things

(showing a bird) is on the branch (showing the branch on the picture) etc.

- Internalize the meaning of the words (bird, branch, girl, mat, frog, leaf) from the context. Teacher can use the six step model for teaching vocabulary.

- Ask the students to repeat the words three times.
- State the words in the context from the text.
- Explain the meaning with a student-friendly way.
- Highlight phonics or spelling item.
- Have the students, in pairs, say a sentence back and forth.
- Tell the students when they will see the phrase and how they will use it orally or in writing.

Activity 3

- Speak some sentences with 'on' showing the concrete objects on them. i.e. (Showing a pen on a desk) The pen is on the desk. The rubber is on the desk. The bag is on the desk.
- Let the students practise with teachers. The teacher speaks these sentences and students repeat them.
- Give students sufficient practice with substitution drill:

Teacher : The bag is on the table.

Students : The bag is on the table.

Teacher : Eraser

Students : The eraser is on the table.

Make students practise as many as they can.

2. Where is the cat?

10 minutes

Activity 1

- Ask the students to talk about where the cat is. Let them see the pictures and read the words beneath them.
- Familiarize the vocabulary (roof, cupboard, table).
- Ask the students to see in the picture to work in pairs. One student asks 'Where is the ...?' and other replies 'It is on the ...!'.

Where is the cat?



on the roof



on the table



on the cupboard



on the book

3. Read and write

15 minutes

Activity 1

- Talk about the picture.
- Read the lesson at a natural speed and ask the students to listen. Point the lines while reading and also ask the students to put the fingers on the lines.
- Read again and ask the students to follow you. The students also point when they are reading.
- Read with students together and let them gradually read alone with support.
- Ask some of the students to read the text. Check and monitor when they read.

Read and write.

The Story Book

This is a book.
The book is on the chair.
There are many stories in the book.
Children like to read stories.



1. Is this a book?
a. yes _____ b. no _____
2. The book is _____ the chair.
a. in _____ b. on _____ c. under _____
3. The book has _____
a. songs _____ b. stories _____ c. poems _____

Activity 2

- Discuss the activity orally. Instruct and help them find the answers.

Activity 3

- Ask the students to do the task in their workbook.
- Check their writing.

4. Colour the ball on the box

5 minutes

Activity 1

- Talk about the picture. Ask the questions: Where is the ball in first, second and third pictures?

Colour the ball on the box.



- Talk about which colour is good for the ball.
- Talk about how many types of ball they have seen. Ask them to name i.e. football, volleyball, basketball and so on.

Activity 2

- Ask the students to colour the ball.

5. Look and write three sentences

10 minutes

Activity 1

- Ask the students to look at the picture. Discuss what they can see there. Introduce

the words 'donkey, dog, cat and hen'.

- Make as many sentences as possible about the picture i.e This is a donkey. The dog is on the donkey.
- Ask the students to practise using these words.
- Ask the students to write three sentences about the pictures.
- Check the sentences.

Look and write three sentences.



1. _____

2. _____

3. _____

Lesson 86

The Rainbow

In this lesson, there are four topics to cover:

1. Look and sing (Listening and speaking)
2. Look and read (Listening and speaking)
3. Read and write (Reading)
4. Look and write their colour (Writing)

Objectives:

- Recite a song of rainbow.
- Listen to the words of colour and act them.
- Read a very short text and do the tasks based on it.
- Write the names of colour.

Materials:

Traffic signal placards, pictures.

Before you teach:

1. Study the workbook thoroughly.

1. Look and read

15 minutes

Activity 1

- Talk about the picture. Ask the name of the picture. Ask if they have seen it in real life. Talk when it is seen.
- Ask the students to share if they have known some stories about it.
- Tell them why rainbow is seen in the sky. You can tell them the stories related to the rainbow if you know.

Look and sing.

Oh, rainbow, oh rainbow,
How lovely are you !
Purple, red and orange too,
Yellow, green and blue so true.
Oh, rainbow, oh, rainbow,
How lovely are you !



Activity 2

- Talk about the colours it has. Demonstrate the colour and make them familiar with its meaning, pronunciation and spelling. (Seven colours:)

Activity 3

- Sing the chant to the students. They will listen. Repeat it several times with students till they come to know the tune.
- Ask the students to recite it in group, in pair or individually.

2. Look and read

10 minutes

Activity 1

222

- Ask the students to observe the picture. Ask their name in Nepali or in their own language.
- Show the picture and read the chunk to familiarize the vocabulary. i.e This is a bird. It is black. Black bird
- Read these phrases and ask the students to repeat followed by the practice of using them in sentences in group and pair.



3. Read and write

25 minutes

Activity 1

- Ask the students if they have seen the traffic lights. Ask if they knew their meaning.
- Familiarize the traffic signal and their meanings.



Activity 2

- Draw a traffic light signal as a placard and put on the classroom door. Practise using it supposing the traffic light on the streets. (You have to cover the two colours and show only one at a time while using.)

Activity 3

- Show the red light, yellow light and green light placard randomly and ask the students to say its meaning quickly.

Activity 4

- Read the lesson at appropriate speed as a model. Read with students together.
- Ask the students to read the text again and do the task. Read the question to students. Model answering the first question with students using thumbs up/down to find if the answer is in the story.
- Ask the students do the remaining questions. Do it first orally and then ask them to write in their workbook.
- Check the students writing.

4. Look and write their colour

10 minutes

Activity 1

- Ask to look at the pictures and ask if they knew them. Familiarize them (crow, sheep, mango, apple, tree).

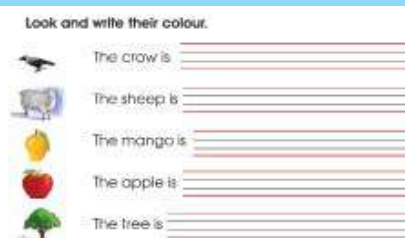

Activity 2

- Ask the students to see the picture and tell the colour.
- Ask them to write their colour in the blank spaces.

Lesson 87

Red Rose

In this lesson, there are five topics to cover:

1. Look and read (Listening and speaking)
2. Colour the name of the flower (Speaking and writing)
3. Read and write (Reading)
4. Look and make words (Vocabulary)
5. Make sentences (Writing)

Objectives:

- Listen to the words of flower and act them.
- Identify the words of flower and colour them.
- Read a very short text and do the tasks based on it.
- Form correct words from the unscrambled letters.
- Form correct sentences using the words given.

Materials:

pictures, sentence cards, word cards.

Before you teach:

1. Study the workbook thoroughly.

1. Look and read

20 minutes

Activity 1

- Show pictures of the flowers given in the workbook. Build up an understanding of the new vocabulary by pointing to the new flower items

For example:

Teacher : Point to a rose

Child : (Points to a rose)

Teacher : That's right. What are you showing me?

Child : a rose

Look and read.



The rose is red.



The lotus is white.



The sunflower is yellow.



The marigold is orange.

- Build up an understanding of all flowers given in the workbook. Also focus on pronunciation and spelling of the words.
- Ask If the children have seen or have these flowers at home. Ask them to talk about those flowers in terms of colours.

Activity 2

- Ask the children what other flowers they have in their house or seen in the locality. Talk about their colour. i.e Sayapatri is yellow. Makhamali is red.

Activity 3

- Read the text with a correct model and ask the students to follow.
- Then ask the students to read in pairs. On this phase, ask a student to read once while other one checks and supports in reading and vice versa.

Activity 4

Ask the children draw the picture of the flowers in exercise book. They work in pairs or groups to draw, colour, cut and paste their pictures on to a large sheet of paper prepared by the teacher. Write labels and captions. Practise reading the words.

2. Colour the names of the flowers. 10 minutes

- Ask the students to observe the balloon in the workbook. Discuss which one is flower and which one is not.
- Talk about the colours of these flowers.
- Ask the students to colour the balloon with flower name with the right colour. Inform them not to colour the balloon which does not contain the flower name.

Colour the name of the flowers.

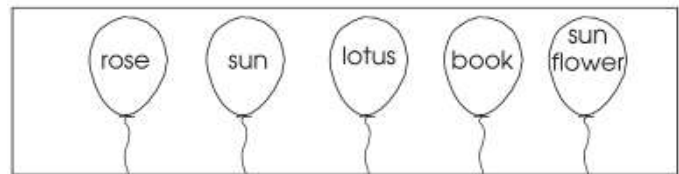

3. Read and write 20 minutes

- Show the students the picture and ask questions: Which flower is it? What is its colour? Are these flowers in your home or in your locality? if not, why?
- Read the text aloud at normal speed for the students when they listen to you and point to the lines.
- Ask the questions while reading and also focus on the new vocabulary.
- Ask the students to choose the correct answer and write in the workbook.
- When they finish, ask to compare their answers in pairs.

Read and write.

The Rose

This is a rose plant.
The rose is red.
The leaf is green.
The plant is red and green.



1. This is a _____ plant.
2. The rose is _____ in colour.
3. The leaf is _____ in colour.
4. The plant is _____ in colour.

4. Look and make words

5 minutes

Activity

- Ask the students to name the picture in their mother tongue.
- Ask them if they knew the words in English.
- Practice their pronunciation, spelling and use. For this teacher presents the correct pronunciation of the words, let the students practise with their spelling orally for some time and uses the word in simple sentences.
- Ask the students to make sentences using these words.
- Ask the students to look and make words in the workbook.

Look and make words.



5. Make sentences

5 minutes

- Discuss making sentences using these words.
- Ask the students to make sentences using the given words.

Make sentences.

1. rabbit : _____
2. hand : _____
3. basket : _____

6. Project Task

Ask the students to collect some of the flowers they have in their house or in the locality and paste them in their exercise book. Write their names below the flower

Lesson 88

This is a Bag

In this lesson, there are five topics to cover:

1. Look and read (Listening and speaking)
2. Look and read (Listening and speaking)
3. Read and write (Reading)
4. Look and write five words (Vocabulary)
5. Write three sentences (Writing)

Objectives:

- Listen to and say the words in our surroundings.
- Ask questions using 'What is this?' and respond them.
- Read a very short text and do the tasks based on it.
- Identify and write correct words from the pictures.
- Write three sentences based on the pictures.

Materials:

pictures, word cards

Before you teach:

1. Study the workbook thoroughly.

1. Look and read

15 minutes

Activity 1

- Ask the question 'What is this?' showing the different things you have and also answer them with 'This is a). i.e What is this? This is a pen and so on.

Activity 2

- Ask each student to show five of the things they have and ask the question 'What is this?' to the class. The class replies: This is a.....

Activity 3

- Ask the students to observe the classroom. Practise asking and answering the question.

Activity 4

- Ask the students to look and read the text in the workbook.



2. Look and read

15 minutes

Activity 1

- Ask the students to see out of the classroom. Tell them to say what they see.

Now, help them to tell these things with 'That is a'. i.e That is a tree. That is a car. That is an apple etc. Practise as many as they can do.

Look and read.



Activity 2

- Collect 10 things or objects that you find in the class. Introduce it with 'This is a/an!' showing it nearby you and 'That is a/an.....!' putting it far from you. Distinguish the use of 'this and that' from context.

Activity 3

- Ask each student say two sentences beginning with 'This/That is a/an!'. Help and monitor the students.

3. Look and read

15 minutes

Activity 1

- Ask the students: What do you see in the picture? Call 2-3 students to share. Let students tell partners what they think will happen in the story. Monitor and help students.

Look and read.

The Cow

This is a cow.
The cow eats hay and grass.
It gives us milk.
The cow is our national animal.



1. This is a _____
2. The cow eats _____
3. It has four _____
4. It gives us _____

Activity 2

- Read the lesson at appropriate speed as a model.
- Read with students together. Ask the students to point out while they are reading.
- Let the students read alone and monitor them.

Activity 3

- Teach the words (hay, grass, national, animal, give, eat) in a student friendly way.

Activity 4

- Ask the students read the text again and do the task. Read the question to students. Model answering the first question with students using thumbs up/down to find if the answer is in the story.
- Ask the students do the remaining questions. Do it first orally and then ask them to write in their workbook.
- Check the students writing.

4. Look and write five words

7 minutes

Activity 1

- Ask students to see the picture. Help them to identify different things in the picture (tree, crane, fish, lotus, frog, lake/pond, field etc).
- Read out the words, one at a time. Use word and picture cards (tree, crane, fish, lotus, frog, lake/pond, field etc) to explain their meaning. You may refer to previous activities where these words were encountered. Do familiarize pronunciation and spelling.

Look and write five words.



1. _____
2. _____
3. _____
4. _____
5. _____

Activity 2

- Read out the words again and ask pupils to identify the correct words.

Activity 3

- Ask the students to match the word and picture card.

5. Write five sentences about the picture.

8 minutes

Activity 1

- Ask students to observe the picture again and describe the picture. Indicate items that represent key words picture (tree, crane, fish, lotus, frog, lake/pond, field etc). Say these words aloud and ask pupils to repeat.

Write three sentences about the picture.

1. _____
2. _____
3. _____

Activity 2

- Use these words to describe the picture i.e This is a pond. This is a crane. It eats/ catches fish. Fish lives in water. The lotus is in the pond etc. Do this pointing to the respective pictures.
- Ask the students to carry out this describing activity orally prior to asking them to do the workbook activity.

Activity 3

- Ask the students to write three sentences individually about the picture in the given spaces.
- Encourage the students to be as creative as possible in writing sentences.

Theme: My Belongings

Children love their belongings a lot. They want to keep their things safe. They become happy when someone praises their belongingness. In such case, they can be useful for language teaching. A learner will learn to use prepositions of location, take care of his, her belongings, follow model reading and recite rhymes throughout the theme. The soft skills like taking care of one's belongings, communication skills, active listening, and respect for diversity will also be enhanced.

Number of Lessons: 4

Lesson Topics

1. In the Bag (Lesson 89)
2. Under the Table (Lesson 90)
3. Things at Home (Lesson 91)
4. Where are my Socks? (Lesson 92)

Soft skills

- Integrity/honesty
- Collaboration
- Taking care of one's belongings
- Active listening

Language function

- Describing possession

Skill-wise learning outcomes

Listening

1. Match spoken words to printed words (e.g. the teacher pronounces /pin/, and the student selects pin from a set of three word cards).
2. Recognize and comprehend words and simple expressions.
3. Respond to the audio or the teacher non-verbally and verbally.
4. Respond to simple commands and questions.
5. Perform different kinds of listening tasks (e.g. drawing, matching, etc.).

Speaking

1. Pronounce grade appropriate words correctly.
2. Ask and answer short, simple questions.
3. Sing or recite a song/chant by listening to the teacher or an audio.
4. Name people, objects and places and describe them with adjectives.

Reading

1. Recognize and read familiar words accompanied by visuals
2. Perform rhymes and chants with appropriate rhyme and rhythm.
3. Understand the meaning of grade appropriate words.
4. Read words, simple sentences and short paragraphs correctly.
5. Retrieve specific information from simple sentences.
6. Do different kinds of comprehension tasks (answering verbally, matching, action, etc.)

Writing

1. Write letters and words in a straight line from left to right with regular spacing between words.
2. Copy letters and highly frequent familiar words and phrases correctly and reproduce them.
3. Combine and recombine different letters to form words, and put the words in correct order to form simple sentences.
4. Use correct spelling of the words.
5. Write simple phrases and sentences independently.
6. Demonstrate good handwriting skills.

Lesson 89

In the Bag

In this lesson, there are five topics to cover:

1. Look and read (Listening and speaking)
2. Where are they? (Listening and speaking)
3. Read and write (Reading)
4. Look and make words (Vocabulary)
5. Make sentences (Writing)

Objectives:

- Listen to the words of belongings and use them in their sentences.
- Ask questions beginning with 'where' and respond using 'in'.
- Read a very short text and do the tasks based on it.
- Form correct words from the unscrambled letters.
- Form correct sentences using the words given.

Materials:

pictures, sentence cards, word cards.

Before you teach:

1. Study the workbook thoroughly.

1. Look and read

15 minutes

Activity 1

- Use the picture in the *Work Book* (p.187) to talk about the different objects in the room.
- Make lists of all the objects on the board. Ask the children, which objects they have and which they have not. (Words: Bag, cupboard, cat, banana, basket, picture, bed, pillow, table, vase)
- Teach the children to pronounce these words and to understand their meaning by using pictures and other aids.

Look and read.

This is Sagun's room. There are many things in her room.



The book is in the bag.

The cat is in the cupboard.

The bananas are in the basket.

Activity 2

- Read the section 'Look and read'. Relate the picture while reading. Question like:

'Where is the book? Where is the cat? Where are the bananas? etc'. Focus on the use of 'in' to show location while interpreting.

- Ask the students to read in group and alone.

Activity 3

- Create different situations to for using 'in' i.e in the classroom, in the box, in the room, in the bucket, in the pot etc. Ask the questions like: 'Where is the pen? And students respond with 'in the'etc.

2. Where are they?

10 minutes

Activity 1

- Ask the students to look at the picture and talk about their location.
- Familiarize the vocabulary (circle, rat, ball, bucket, parrot, cage, cowshed).

Where are they?



in the circle



in the bucket



in the cage



in the cowshed

Activity 2

- Ask the students to question and respond.
- One student questions: Where is the rat?
- Other students respond: In the circle

Activity 3

- Come up with additional situations to use 'in'. Question and ask students to observe and respond with 'in'.

3. Read and write

20 minutes

Activity 1

- Make a short discussion about the picture. Ask the students: Who is the girl? Where is she? What are the things you see in the picture?

Activity 2

- Read the lesson at appropriate speed as a model.
- Read with students together. Ask the students to point out while they are reading.
- Let the students read alone and monitor them.

Read and write.

The Ball

Rita has a ball.
The ball has two colours.
The ball is in the box.
The box is in the cupboard.
The cupboard is in the room.



1. Rita has a _____
2. The ball has _____ colours.
3. The ball is _____ the box.
4. The box is _____ the cupboard.

Activity 3

- Ask the students to see the task. Read them for the students. Clarify what they have to do.
- Show how to do a task as a model.
- Ask the students to read the text again and do the remaining questions. Do it first orally and then ask them to write in their workbook.
- Check the students writing.

4. Look and make words.

5 minutes

Activity 1

- Show the picture and ask the students to guess.
- Ask the students to form the correct word.

Look and make words.



rofo



bursh



paly

Do it orally first and then ask them to write in their exercise book.

5. Write sentences

10 minutes

Activity 1

- Help student making as many sentences as they can i.e. This is a roof. It is red. etc
- Ask the students to make their own sentences.
- Ask the students to do the task in their workbook.
- Check the students' writing.

Write sentences.

1. roof :

2. brush :

3. play :

Lesson 90

Under the Table

In this lesson, there are five topics to cover:

1. Look and read (Listening and speaking)
2. Where are my things? (Listening and speaking)
3. Read and write (Reading)
4. Look and write five words (Vocabulary)
5. Write three sentences about the picture (Writing)

Objectives:

- Listen to the words of belongings and use them in their sentences.
- Ask and answer about location using 'under'.
- Read a very short text and answer the questions based on it.
- Identify and write five key words related to picture.
- Write sentences about the picture.

Materials:

pictures, sentence cards, word cards.

Before you teach:

1. Study the workbook thoroughly.

1. Look and read

10 minutes

Activity 1

- Show the picture in the *Work Book* (p.189) and ask the students to name the objects there.
- Ask the students to describe where these objects are. They can use their mother tongue this time.
- Now, describe the picture. Use under where possible.
- Help students describe the picture. Give clues while doing so i.e Cat under the bed.

Look and read.

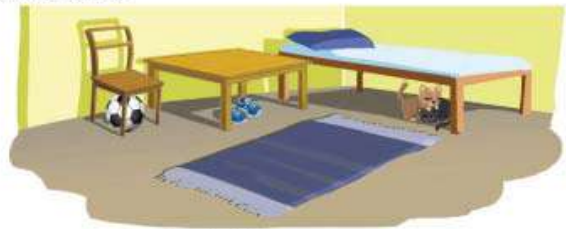

The shoes are under the table.

The cat is under the bed.

The ball is under the chair.

Activity 2

- Read the section 'Look and read' and students listen.
- Ask the students to read in group and alone.

Activity 3

- Ask the students to speak based on the worksheet

2. Where are my things?

10 minutes

Activity 1

- Ask the students to look at the picture and act about them.
- One student questions: Where is my bat?
- Other students respond: under the umbrella.



Activity 3

- Come up with additional situations to use 'under'. Question and ask students to observe and respond with 'under'.

3. Read and write

20 minutes

Activity 1

- Ask the students: What do you see in the picture? Where is the monkey? What is the monkey doing? Does monkey have a short tail? etc

Activity 2

- Read the lesson at appropriate speed as a model. Read again and ask the students to follow.
- Read with students together. Ask the students to point out while they are reading. Leave to read themselves after they get confident.
- Let the students read alone and monitor them.

Activity 3

- Ask the students to see the task. Read them for the students. Clarify what they have to do.
- Show how to do a task as a model.
- Ask the students to read the text again and do the remaining questions. Do it first orally and then ask them to write in their workbook.
- Check the students writing.

Read and write.

The Monkey

This is a monkey.
The monkey has a long tail.
The monkey is eating a banana.
The monkey is under the tree.



1. Is this a monkey?

2. Where is the monkey?

The monkey is _____

3. What is the monkey eating?

The monkey is eating _____

4. Look and write five words

10 minutes

Activity

- Show the picture and ask the questions:
Who are they? What are they doing?
What are they wearing? What is the boy carrying? Is the girl's hair short or long? What is the colour of the bag?
- Help and give clues to get the answer themselves. Repeat the questions until all the students say the correct answer.
- Ask them to name as many words as they can see from the picture: girl, boy, hair, bag, shirt, shoes, skirt, trousers, socks, blue, white, red, black, long, short etc.
- Ask the student to write five words in their workbook. Do it orally first and then ask them to write.

Look and write five words.



1. _____
2. _____
3. _____
4. _____
5. _____

5. Write three sentences about the picture.

10 minutes

Activity

- Recap the picture description they did in the previous task.
- Ask the students to make their own sentences based on the picture.
- Ask the students to do the task in their workbook.
- Check the students' writing.

Write three sentences about the picture.

1. _____
2. _____
3. _____

Lesson 91

Things at Home

In this lesson, there are four topics to cover:

1. Things at home (Listening and speaking)
2. Look and write (Listening and speaking)
3. Read and write (Reading)
4. Look and write three sentences (Writing)

Objectives:

- Listen to and talk about the words of belongings at home.
- Form correct words from the unscrambled letter.
- Read a very short text and answer the questions based on it.
- Write sentences about the picture.

Materials:

pictures, word cards.

Before you teach:

1. Study the workbook thoroughly.

1. Look and read

20 minutes

Activity 1

- Ask the students to see the picture of a room and name different objects they see there. They can use their mother tongue if they don't know English. Elicit that there are: Fan, table, clock, picture, Television, sofa, cupboard, mat and table.
- Ask students what other things they have in their own room.

Look and discuss.



Activity 2

- Teach these words (Fan, table, clock, picture, Television, sofa, cupboard, mat and table) with the help of pictures and word cards. Teach their meaning, pronunciation and use.

Activity 3

- Ask the students to draw the picture in their exercise book and ask them to label

them under the corresponding pictures.





2. Look and write

5 minutes

Activity 1

- Ask the students to see the picture and name them. Ask them the spelling of the words.
- Ask the students to rearrange the letter and make words.
- Ask them to write in their workbook.

Look and write.

	colck	_____
	mrriorr	_____
	fna	_____
	taebl	_____
	bde	_____

3. Read and write

20 minutes

Activity 1

- Make a short discussion about the picture. Ask the students: What is this picture of? What are the things you see in the picture? Is this a living room or reading room?

Activity 2

- Read the lesson at appropriate speed as a model.
- Introduce the new words (colourful, picture, wall, rack, story) in a student-friendly way. Focus on meaning, pronunciation and use.
- Read with students together. Ask the students to point out while they are reading.
- Let the students read alone and monitor them.

Activity 3

- Ask the students read the text again and do the task. Read the question to students. Model answering the first question with students.
- Ask the students do the remaining questions. Do it first orally and then ask them to write in their workbook.
- Check the students writing.

Read and write.

My Reading Room

This is my reading room.
The room is big. It is very colourful.
There are pictures on the wall.
There are books in the rack.
I read story books.



1. Is the room big?

2. Where are the pictures?
The pictures are _____
3. Where are the books?
The books are on a _____
4. What do I read?
I read _____

4. Look and write three sentences.

15 minutes

Activity 1

- Show the picture and ask the questions: What are the things you see in the picture?

Help them to name correctly (Table, chair, table clock, diary, pen pencil, book, exercise book, sharpner).

- Ask the students to write the words in their exercise book.

Look and write three sentences.



1. _____

2. _____

3. _____

Activity 2

- Have a short description of the picture: This is my reading table. The table is big. The chair is small. There are pencils, sharpener and eraser on the table. There is a table clock. There are books on the table. I read the books.
- Help students describe the picture. This can be done in group.
- Ask some of the students describe in front of the class.

Activity 3

- Ask the students to do the task in their workbook.

Lesson 92

Where are my Socks?

In this lesson, there are four topics to cover:

1. Look and read (Listening and speaking)
2. Read (Listening and speaking)
3. Read and write (Reading)
4. Name the dresses and sing the song (Listening and writing)

Objectives:

- Listen to and talk about the cloths.
- Read a very short text and answer the questions based on it.
- Recite a chant about cloths and name the dresses.

Materials:

pictures, word cards.

Before you teach:

1. Study the workbook thoroughly.

1. Look and read

15 minutes

Activity 1

- Talk about the picture. Ask the students to guess what he might be searching for.
- Read and act out the sentences. Ask the students to follow. Also focus on the sentence pattern.
- Ask the students act out the sentences.



Activity 2

- Ask the students to similar act out with the goods and things they have.

2. Read

15 minutes

Activity 1

- Help students to identify what they see in the pictures. Ask them which they have worn and which they have not worn. Talk about who can wear these cloths: boys, girls or both.



- Say the words one at a time and explain their meaning as required. Use pictures to familiarize the meaning.
- Read out the words and ask students to repeat. Words: - shirt, frock, tie, socks, ribbon, jacket.

Activity 2

- Show the pictures randomly (shirt, frock, tie, socks, ribbon, jacket) and ask the students to name item in the picture as fast as possible.

3. Read and write

20 minutes

Activity 1

- Make a short discussion about the picture. Ask the students: What do you see in the picture? What is he wearing? Where is he going? What does the arrow show? What might be the lesson about?

Activity 2

- Read the lesson at appropriate speed as a model.
- Read with students together. Ask the students to point out while they are reading.
- Let the students read alone and monitor them.

Activity 3

- Teach the words (put on, trousers, carry) in a student friendly way. Focus on meaning, pronunciation and their use.

Activity 4

- Ask the students read the text again and do the task. Read the question to students. Model answering the first question with students using thumbs up/down to find if the answer is in the story.
- Ask the students do the remaining questions. Do it first orally and then ask them to write in their workbook.
- Check the students writing.

Read and write.

Bunny Goes to School

This is Bunny.
 He puts on blue shirt and trousers.
 He puts on red tie and black shoes.
 He carries his school bag.
 And goes to school.



1. Who is he?
He is _____
2. What does he put on?
He puts on _____
3. What does he carry?
He carries _____
4. Where does Bunny go?
Bunny goes to _____

4. Name the dresses and sing the song.

10 minutes

Activity 1

- Talk about the girl. Talk about what she is wearing. Use pictures to introduce the dresses.

Activity 2

- Make students listen to the song a few times. Point to the lines while reading. Encourage them to sing along when they feel somewhat confident

Activity 3

- Ask them to write the name of the dresses in the workbook.

Name the dresses and sing the song.



What ! What ! What !
What do you wear on your head?
What do you wear on your head?
A hat ! A hat ! A hat !
A hat ! A hat ! A hat !

Theme: Our Culture

The theme 'Our Culture' has been inculcated in the curriculum so that the cross-cultural awareness can be developed in the students for harmonious life in the society. This theme is expected to help the students talk about different festivals celebrated in our society and different religious places of different religions.

Number of Lessons: 2

Lesson Topics

- Dashain (Lesson 93)
- Birthday (Lesson 94)

Soft skills

- Tolerance
- National Identity
- Democratic participation
- Respect for diversity
- Communication
- Building rapport with others
- Intercultural skills

Language function

- Asking and answering about ages
- Understanding and using numbers (One to twenty)

Skill-wise learning outcomes

Listening

1. Match spoken words to printed words (e.g. the teacher pronounces /pin/, and the student selects pin from a set of three word cards).
2. Recognize and comprehend words and simple expressions.
3. Respond to the audio or the teacher non-verbally and verbally.
4. Respond to simple commands and questions.
5. Perform different kinds of listening tasks (e.g. drawing, matching, etc.).

Speaking

1. Pronounce grade appropriate words correctly.
2. Give basic personal information about themselves (e.g. name, address, family, nationality) using short words and phrases.
3. Ask and answer short, simple questions.
4. Sing or recite a song/chant by listening to the teacher or an audio.

Reading

1. Recognize and read familiar words accompanied by visuals.
2. Perform rhymes and chants with appropriate rhyme and rhythm.
3. Understand the meaning of grade appropriate words.
4. Read words, simple sentences and short paragraphs correctly.
5. Retrieve specific information from simple sentences.
6. Do different kinds of comprehension tasks (answering verbally, matching, action, etc.)

Writing

1. Write letters and words in a straight line from left to right with regular spacing between words.
2. Copy letters and highly frequent familiar words and phrases correctly and reproduce them.
3. Combine and recombine different letters to form words, and put the words in correct order to form simple sentences.
4. Use correct spelling of the words.
5. Write simple phrases and sentences independently.
6. Give basic personal information in writing (e.g. name, address, age, nationality).
7. Demonstrate good handwriting skills.

Lesson 93

Dashain

In this lesson, there are five topics to cover:

1. Look and read (Listening and speaking)
2. Look and read (Listening and speaking)
3. Read and write (Reading)
4. Look and make words (Vocabulary)
5. Write sentences (Writing)

Objectives:

- Listen to the words of festival and act them.
- Ask questions using 'Where...?' and respond them.
- Read a very short text and do the tasks based on it.
- Form correct words from the unscrambled letters.
- Form correct sentences using the words given.

Materials:

pictures, sentence cards, word cards.

Before you teach:

1. Study the workbook thoroughly.

1. Look and read.

15 minutes

Activity 1

- Ask students to observe the picture and ask them to say about them. i.e What can you see in the picture?
- Continue to ask about these pictures i.e. when do you do these?
- Encourage the students retell their experience.

Look and read.



Dashain



Tihar



Chhath



Christmas



Eid



Lhosar

Activity 2

- Describe each picture for the students. Draw their attention to the words below the pictures and read them aloud. Ask the students to repeat after you.

Activity 3

- Point to the words and pictures at a time and ask (i) the class and (ii) individual

students to speak these words. Also speak the words and ask the students to point the words.

Activity 4

- Discuss what is done in each of the festivals.

2. Look and Read.

15 minutes

Activity 1

- Show pictures of different holy place people go for pray to the children. Use the picture in the Work Book (p. 197)
- Ask them if they have visited in any of such places. Ask them to name what they can see in the picture. Accept names in Nepali. Ask if they have different name in local languages. Ask them why people go to these places.
- Ask them to talk about how people pray in such places.

Look and read.



Activity 2

- Teach the children to say and understand these words: Temple, church, monastery, and mosque; Hindu, Christian, Buddhist, and Muslim. Use pictures to make them understand. Show where they go for pray and ways of praying.

Activity 3

- Demonstrate how Hindu, Christian, Buddhist and Muslim pray in their holy place and ask the question 'Where do I go?'. The students may tell the respective words:

Teacher : (With the demonstration of Namaskar) Where do I go?

Students : Temple

Activity 4

- Invite a student at a time to come in front of the class and ask him/her perform an action that relates to one of the holy places (temples, church, monastery and mosque) as demonstrated by teacher with the question "Where do I go? The rest of the class guesses what that holy place is.
- Ensure the sufficient practice in pair and individually so that they are able to use the expression and have the clear concept.

3. Read and write

20 minutes

Activity 1

1. Talk about the pictures. Ask the students if they are in their village. Ask their name. Ask when people go there and why. Ask if there is any special occasion or festivals many people go there.

Activity 2

- Read out the text given as a model.
- Ask the students to read the text with you.
- Pair up students and ask them to do the same. They should point to themselves when they read. Help them in their difficulty.
- Ask the students to read the text individually.
- Ask the students to read the text and find out the answer of the first task. (Temple)
- Ask the students to find the correct answer. Do it first orally, then ask them to write in their workbook.

Read and write.

Where Do They Go?

Hindus go to temple.
Christians go to church.
Buddhists go to monastery.
Muslims go to mosque.
They love one another.
They live together.



1. Hindus go to _____
2. Christians go to _____
3. Buddhists go to _____
4. Muslims go to _____

4. Look and make words.

5 minutes

Activity 1

- Talk about the pictures. Ask the students what they can see. Tell the students that they are related to the words to make.
- Ask the questions like: What is the colour of the boy's shirt? Can you see a ring? When do we sit near fire? In cold or in hot?
- What is the colour of the leaf?
- (Showing the ring in the finger) What is this?

Look and make words.



geern

clod

rnir

Activity 2

- Write the words 'green, cold, and ring' on the board and make as many sentences as possible orally.
- Encourage the students to make their own sentences. Support them.
- Now, ask the students to form the correct words rearranging the letters given and write on the workbook.

5. Write sentences

5 minutes

Activity 1

- Ask the students to write their own sentences using the patterns that they have practised.

Write sentences.

1. green :

2. cold :

3. ring :

Activity 2

- Handwriting (As a classwork or Homework): A short time should be set aside each day for practicing good handwriting skills.

Lesson 94

Birthday

In this lesson, there are three topics to cover:

1. Look and read (Listening and speaking)
2. Read and write (Reading)
3. Read (Reading)

Objectives:

- Sing a birthday chant and wish someone's birthday.
- Read a short text and answer questions.
- Read and write the numbers from 1 to 20 in words.

Materials:

pictures, word cards. word cards and number cards for 1-20

Before you teach:

1. Study the workbook thoroughly.
2. Have the materials ready.

1. Look and Read.

20 minutes

Activity 1

- Talk about the pictures. Ask different questions like: What do you see in the picture? Do you have these things in your house? When do we use these things? Come to a conclusion that they are used in the birthday celebration.

Activity 2

- Read the chant aloud once and then ask the students to read along. Repeat a number of times so that they can grasp the rhythm/tune of the chant. Also do it in group and individually.

Activity 3

- The class then talks about their birthday celebrations. Students are invited to share their experiences and feelings on that day.

Look and read.



Birthday song
Happy birthday to you.
Happy birthday to you.
Happy birthday to you
dear Punam.
Happy birthday to you.



cake



candle



cup



gifts



balloon



friends

What do you do on your birthday?

Activity 4

- Ask the students if they have the birthday on that day. If yes, let all the students celebrate his/her birthday and wish him/her for birthday. If not, pretend to celebrate the birthday of a student who has it in the earliest.

Activity 5

- Introduce the key vocabulary given in the workbook (cake, candle, cup, gifts, balloon, and friends) subtly. Use the pictures given in the workbook and other appropriate ways for introducing them.

Activity 6

- Let the students play the game 'Run to the Board'.

Procedures

- Put the word cards (cake, candle, cup, gifts, balloon, and friends) on the floor below the board.
- Divide the students in two groups (a group of 5 students) and ask them to stand in two rows behind the line drawn in about the six feet.
- Tell the students that they have to pick the word card that is pronounced by the teacher as fast as possible. Make them clear that there is only one card and the person in a group pick the card fast gains a point. After each attempt the card should be reshuffled.
- The students who attempted from both group go to the last place of the line. It should be repeated till all the group of five gets a chance to try.
- Finally, the group who is able to grab more points is the winner.

Note: It can be played outside and a number of variations can be made.

Read and write.

Punam's Birthday

It is Punam's birthday.
She gets many gifts.
Now, she is six years old.
It is a special day for her.
We all wish her a happy birthday.



1. Whose birthday is it?

2. How old is Punam now?

3. What does she get on her birthday?

4. What do we wish her on her birthday?

2. Read and write. 20 minutes

Activity 1

- Talk about the pictures.
- Ask the students recall what they generally do while celebrating the birthday. Also talk about preparations for the occasion.

Activity 2

- Read aloud and ask the students to follow in their textbooks. Explain as required and read aloud again, this time encouraging pupils to echo you.
- Ask the student to read in pair as a shared reading.
- Also let them practice independent reading.

Activity 3

- Ask the students to read the text and help them to find out the answer of the first task
- Ask the students to find the correct answer other questions. Let them do it orally first, then ask them to write in their workbook. Support them while doing the task.

3. Read.

20 minutes

Activity 1

- Read the number and words for the students. Students follow till they have understood the correct order from one to twenty.
- Ask the students to read them.

Read

1 one	6 six	11 eleven	16 sixteen
2 two	7 seven	12 twelve	17 seventeen
3 three	8 eight	13 thirteen	18 eighteen
4 four	9 nine	14 fourteen	19 nineteen
5 five	10 ten	15 fifteen	20 twenty

Activity 2

- Ask the students count the things and relate it to its writing in word. Use a variety of ways to consolidate the number.

Activity 3

- Put the 'word card' and 'number card' together. Mix them randomly. Now ask the students to match each word with the correct number.

Activity 4

- Give each student a 'word card' where the number from 1-20 are written in word randomly. Ask them to move here and there till the teacher signals 'sit in order'. A bell or teacher's instruction can be used for it. When the teacher signals or sounds to 'sit in order', the students immediately have to sit in order from 1 to 20 according to the number they hold.

Theme: Communication Technology and Market

Communication Technology and Market is one of the themes prescribed in the curriculum. The texts and activities presented in the lessons are related to this theme. It will support the learners to get exposure to the contents and vocabularies about this theme. As a result, the learners will be able to comprehend and talk about them.

Number of Lessons: 3

Lesson Topics

1. Ramu Is a Farmer (Lesson 95)
2. Rice and Curry (Lesson 96)
3. Vehicles (Lesson 97)

Soft skills

- Communication
- Information management
- Respecting
- Building rapport with others
- Multi-literacy skills

Language function

- Talking about jobs

Skill-wise learning outcomes

Listening

1. Match spoken words to printed words (e.g. the teacher pronounces /pin/, and the student selects pin from a set of three word cards).
2. Recognize and comprehend words and simple expressions.
3. Respond to the audio or the teacher non-verbally and verbally.
4. Respond to simple commands and questions.
5. Perform different kinds of listening tasks (e.g. drawing, matching, etc.).

Speaking

1. Pronounce grade appropriate words correctly.
2. Give basic personal information about themselves (e.g. name, address, family, nationality) using short words and phrases.
3. Ask and answer short, simple questions.
4. Sing or recite a song/chant by listening to the teacher or an audio.

Reading

1. Recognize and read familiar words accompanied by visuals
2. Perform rhymes and chants with appropriate rhyme and rhythm.
3. Understand the meaning of grade appropriate words.
4. Read words, simple sentences and short paragraphs correctly.
5. Retrieve specific information from simple sentences.
6. Do different kinds of comprehension tasks (answering verbally, matching, action, etc.)

Writing

1. Write letters and words in a straight line from left to right with regular spacing between words.
2. Copy letters and highly frequent familiar words and phrases correctly and reproduce them.
3. Combine and recombine different letters to form words, and put the words in correct order to form simple sentences.
4. Use correct spelling of the words.
5. Write simple phrases and sentences independently.
6. Demonstrate handwriting skills.

Lesson 95

Ramu Is a Farmer

In this lesson, there are three topics to cover:

1. Read and act (Listening and speaking)
2. Look at the picture and write the words (Reading)
3. Write (Writing)

Objectives:

- Listen and identify jobs such as farmer, teacher, porter, doctor, driver, etc.
- Talk about jobs.
- Identify job related words accompanied by visuals.
- Write their parents' job.

Materials:

pictures, sentence cards, word cards.

Before you teach:

1. Study the student workbook thoroughly.
2. Have the materials ready.

1. Read and act.

40 minutes

Activity 1 (Warming up)

- Show them the picture (given on the right) and instruct the students to study.
- Point to each picture and ask question in whole class, in group and individually. (What do you see in the picture?)
- Encourage them to come up with the answers. Let them speak their own language and translate their words into English.

Activity 2 (Listen and do)

- Read the sentences of each picture and instruct them to listen. (Repeat it three/four times)
- Read the sentences of each picture and instruct them to flow him/her.

Read and act.

Ramu is a farmer.
He grows crops.



Sunita is a teacher.
She teaches in a school.



Dal is a porter.
He carries goods.



Prema is a doctor.
She works in a hospital.



Binod is a driver.
He drives a bus.



(Repeat it three/four times)

- Instruct them to read the sentences of each picture.
- Invite some students in front of the class one by one. Instruct them to read sentences of each picture and follow by others. (Support and facilitate them to read the sentences.)
- Ask randomly some students to stand up and read the sentences of each picture. (Focus on slow learners)

Activity 3 (Speaking practice)

- Write the words: farmer, teacher, porter, doctor and driver on the board and make a short discussion. (You can tell the equivalent Nepali words)
- Distribute word cards to each student.
farmer **teacher** **porter** **doctor** **driver**
- Take a word card and demonstrate such as I'm a teacher. I teach in a school.
- Instruct them to perform as their word cards and facilitate them. (This activity can be performed outside the classroom.)
- Instruct them make a pair and talk about his/her partner as a word card. E.g. Reena is a farmer. She grows crops. Monitor and help needy ones.
- Instruct them to make new partner and talk about their partners as a word card.
- Randomly ask some students to perform about himself/herself and partner as a word card.

Activity 4 (Reading for comprehension)

- Write the words: grows, crops, teaches, carries, goods and drives on the boards and make a drill for pronunciation practice.
- Ask them to guess the meaning by reading the sentences of each picture.
- Teach the meaning by showing pictures and examples. Encourage them to tell the meaning in Nepali as well.
- Distribute the worksheet to each student instruct them to do. Monitor and help needy ones.

Worksheet

Matching

Group A

- a. a farmer
- b. a teacher
- c. a porter

Group B

- i. grows crops.
- ii. teaches in a school.
- iii. carries goods.

- | | |
|-------------|--------------------------|
| d. a doctor | iv. works in a hospital. |
| e. a driver | v. drives a car. |

Instruct them to make peer correction and then tell the correct ones in whole class.

2. Look at the pictures and write the words. 10 minutes

Activity 1 (Reading and writing)

- Instruct them to look at the activity “Look at the pictures and write the words”.
- Instruct them to study the given pictures and identify the jobs.
- Instruct them to complete the given task (puzzle). Monitor and help needy ones.
- First instruct them for peer correction and then tell the correct ones in whole class.

Look at the pictures and write the words.

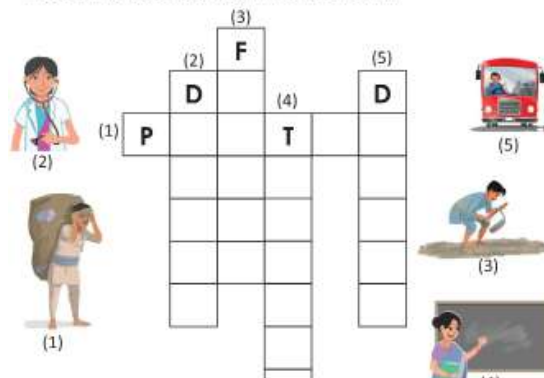

3. Write. 10 minutes

Activity 1 (Writing)

- Instruct the students to study the given questions individually and then discuss in a pairs.
- Write these four questions on the board and keep the space to write the answer.
- Invite some students one by one and ask them to write the answers.
- Instruct them to write the answers in their student workbook. Monitor and help needy ones.

Write.

1. What is your name?

2. Who are there in your family?

3. What does your father do?

4. What does your mother do?

Lesson 96

Rice and Curry

In this lesson, there are three topics to cover:

1. Look and read (Listening and speaking)
2. Look and write (Reading and writing)
3. Look and Read (Reading)
4. Write three sentences about your favourite foods (Writing)

Objectives:

- Listen and identify food items
- Identify and talk about food items accompanied by pictures
- Read a short text and answer questions.
- Write a few sentences about their favourite foods.

Materials:

pictures, word cards, real objects.

Before you teach:

1. Study the workbook thoroughly.
2. Have the materials ready.

1. Look and Read.

20 minutes

Activity (Warming up)

- Ask the students to study the pictures. (given in student workbook)
- Pointing to the picture, ask the questions. “What is it?” “Do you know it?”
- Encourage them to come up with the answers. Let them speak their own language and translate their words into English.

Look and read.

We eat foods. Foods keep us healthy.

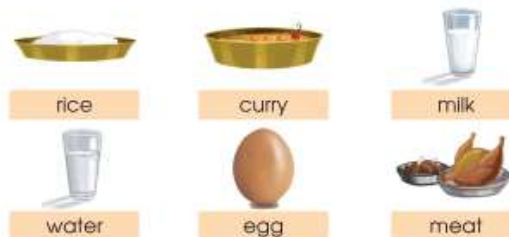

Activity 2 (Listen and do)

- Read the words of each picture and instruct them to listen. (Repeat it three/four times)
- Read the words of each picture and instruct them to flow him/her. (Repeat it three/four times)
- Instruct some students one by one to read the words and follow by others.
- Ask them to guess Nepali equivalent words and tell the equivalent words.

- Make a drill for pronunciation and spelling of the given words.
- Conduct a dictation and instruct them for self-correction and peer correction.
- Monitor and help needy ones.

Activity 3 (Speaking practice)

- Distribute the pictures to each student. (one picture for one student)
- Take one picture and demonstrate as example. E.g. Show the picture of rice and ask “What is it?” It is rice.
- Instruct them to talk in pairs about their pictures. (Also instruct them to change their partners as needed.) Monitor and help needy ones.
- Invite some pairs in front and ask them to perform. Facilitate them as their need.

2. Look and Write. 10 minutes

Activity 1

- Ask them to look at the activity “Look and write” in their book.
- Instruct them to discuss in pairs and small groups (within their desk) and complete the given task.
- Invite two/three students one by one in front of the class and ask them to write the correct word on the board. Help them as needed.
- Instruct them to correct their task as written on the board.

Look and write.



3. Look and read. 20 minutes

Activity 1 (Aloud reading)

- Ask the students to look at the picture and discuss. (Asking such a question “What do you see in the picture?”)
- Read the text and instruct them to listen. (Repeat it two/three times)
- Read the text and instruct them to follow. (Repeat it two/three times)
- Ask some students to read the text one by one and instruct the others to follow. Facilitate them to read correctly as they need.
- Invite some students in front and ask them to read one by one. Facilitate them to read correctly as their need.

Write three sentences about your favourite foods.



Activity 2 (Reading for comprehension)

- Write the comprehension questions with space of writing answers on the board and instruct them to study the questions.
- Instruct them to read the text and find the answers.
- Ask them to write their answers in their notebooks and share it in pairs and small groups.
- Instruct them to discuss in groups and decide the correct answers.
- Invite a student from any group and instruct him/her to write the answers on the board.
- Ask the other groups to correct the answers. Facilitate them to write the correct answers as needed.
- Now, instruct them to write the correct answers in their books. Monitor and help needy ones.

4. Write three sentences about your favourite foods. 10 minutes

Activity 1 (Warming up)

- Ask the students to look at the picture and ask them “What do you see in the picture?”
- Ask them some questions such as ‘What is your favourite food? What are your favourite foods?’ And conduct short discussion.
- Ask them to write the three names of foods that they like. Monitor and help needy ones.

Look and read.

At a Party

Dipu eats rice and curry.

Mina drinks juice.

Padam eats an egg.

Sunita drinks milk.

I like all of them.



1. What does Dipu eat?

2. Who drinks water?

3. What does Padam eat?

4. Who likes all of them?

Activity 2 (Writing)

- Write the names of your favourite three foods on the board. Such as milk, rice and egg.
- Write three sentences about your three favourite foods on the board and instruct them to write three sentences about their three favourite foods in their notebooks.

I drink milk. I eat rice. I like an egg.

- Monitor and help to write the sentences.
- Encourage the students to share their work before you correct them.
- After correction, instruct them to write these sentences in their books.

Lesson 97

Vehicles

In this lesson, there are three topics to cover:

1. Look and discuss (Listening and speaking)
2. Match (Reading)
3. Read and write (Reading)
4. Write three sentences about the picture (Writing)

Objectives:

- Listen and identify the names of vehicles.
- Talk about vehicles by looking pictures.
- Match the words (names of vehicles) with pictures
- Read a short text and answer questions.
- Write a few sentences about vehicle by looking picture.

Materials:

pictures, word cards.

Before you teach:

1. Study the workbook thoroughly.
2. Have the materials ready.

1. Look and discuss.

10 minutes

Activity (Warming up)

- Ask the students to study the pictures. (given in student workbook)
- Pointing to the picture, ask the questions such as ‘What do you see in the picture?’
- Conduct a short discussion.

Activity 2 (Listen and do)

- Writes the words (names of vehicle) on the board.

bus	van	car	aeroplane	bicycle	tempo
-----	-----	-----	-----------	---------	-------

- Read the words and instruct them to listen. (Repeat it three/four times)
- Read the words and instruct them to flow him/her. (Repeat it three/four times)
- Make a drill for pronunciation and spelling.
- Instruct some students one by one to read the words and follow by others.

Look and discuss.



- Read the words and show the related pictures one by one. E. g. Read a word ‘bus’ and show a picture of bus. (Repeat it two/three times)
- Ask them to guess Nepali equivalent words and tell the equivalent words.
- Conduct a dictation and instruct them for self-correction and peer correction.
- Monitor and help needy ones.

2. Match

10 minutes

Activity 1 (Speaking practice)

- Distribute the pictures to each student. (one picture for one student)
- Take one picture and demonstrate as example. E.g. Show the picture of bus and ask “What is it?” It is a bus.
- Instruct them to talk in pairs about their pictures. (Also instruct them to change their partners as needed.) Monitor and help needy ones.
- Invite some pairs in front and ask them to perform. Facilitate them as their need.

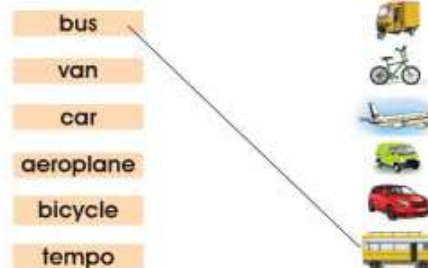

Activity 2 (Reading and matching)

- Ask them to look at the activity “Match” in their book.
- Instruct them to discuss in pairs and small groups (within their desk) and complete the given task.
- Invite two/three students one by one in front of the class and ask them to show their matching to the whole class. Help them as needed.
- Monitor and help them to match words with correct pictures as they need.

3. Read and write

20 minutes

Activity 1 (Aloud reading)

- Ask the students to look at the picture and discuss. (Asking such a question “What do you see in the picture?”)
- Read the text and instruct them to listen. (Repeat it two/three times)
- Read the text and instruct them to follow. (Repeat it two/three times)
- Ask some students one by one to read the text and instruct the others to follow.

Read and write.

The Bicycle

My papa has a bicycle.
The bicycle is red.
The bicycle has two wheels.
The bicycle can go fast.



1. Who has a bicycle?

2. What colour is the bicycle?

3. How many wheels does it have?

4. Can a bicycle go fast?

Facilitate them to read correctly as they need.

- Invite some students in front and ask them to read one by one. Facilitate them to read correctly.

Activity 2 (Reading for comprehension)

- Write the comprehension questions with space of writing answers on the board and instruct them to study the questions.
- Instruct them to read the text and find the answers.
- Ask them to write their answers in their notebooks and share it in pairs and small groups.
- Instruct them to discuss in groups and decide the correct answers.
- Invite a student from any group and instruct him/her to write the answers on the board.
- Ask the other groups to correct the answers. Facilitate them to write the correct answers as needed.
- Now, instruct them to write the correct answers in their books. Monitor and help needy ones.

4. Write three sentences about the picture 20 minutes

Activity 1 (Warming up)

- Ask the students to look at the picture and ask them “What do you see in the picture?”
- Ask them to write the three things what they see in the picture. Monitor and help needy ones.

Write three sentences about the picture.

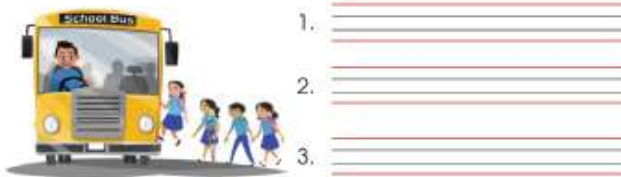

Activity 2 (Writing)

- Write the three things as an example what you see in the picture on the board. Such as school bus, driver and students.
- Instruct them to write three sentences using three things what they see in the picture.

Sample

It is a school bus. The driver drives the bus. The students go to school by the bus.

- Monitor and encourage them to write variety of the sentences.
- Encourage the students to share their work before you correct them.
- After correction, instruct them to write these sentences in their books.

Theme: Fruits and Vegetables

Fruits and vegetables is one of the themes prescribed in the curriculum. The texts and activities presented in the lessons are related to fruits and vegetables. It will support the learners to get exposure to the contents and vocabularies about this theme. As a result, the learners will be able to comprehend and talk about them.

Number of Lessons: 3

Lesson Topics

1. Fruits (Lesson 98)
2. A/An (Lesson 99)
3. Vegetables (Lesson 100)

Soft skills

- Communication
- Creative thinking
- Information management skills
- Problem solving

Language function

- Giving information

Skill-wise learning outcomes

Listening

1. Match spoken words to printed words (e.g. the teacher pronounces /pin/, and the student selects pin from a set of three word cards).
2. Recognize and comprehend words and simple expressions.
3. Respond to the audio or the teacher non-verbally and verbally.
4. Perform different kinds of listening tasks (e.g. drawing, matching, etc.).

Speaking

1. Pronounce grade appropriate words correctly.
2. Ask and answer short, simple questions.
3. Sing or recite a song/chant by listening to the teacher or an audio.
4. Name people, objects and places and describe them with adjectives.

Reading

1. Recognize and read familiar words accompanied by visuals
2. Perform rhymes and chants with appropriate rhyme and rhythm.
3. Understand the meaning of grade appropriate words.

4. Read words, simple sentences and short paragraphs correctly.
5. Retrieve specific information from simple sentences.
6. Do different kinds of comprehension tasks (answering verbally, matching, action, etc.)

Writing

1. Write letters and words in a straight line from left to right with regular spacing between words.
2. Copy letters and highly frequent familiar words and phrases correctly and reproduce them.
3. Combine and recombine different letters to form words, and put the words in correct order to form simple sentences.
4. Use correct spelling of the words.
5. Write simple phrases and sentences independently.
6. Demonstrate handwriting skills.

Lesson 98

Fruits

In this lesson, there are three topics to cover:

1. Look and read (Listening and speaking)
2. Write (Speaking and writing)
3. Read and Writing (Reading)
4. Write three sentences about the picture (Writing)

Objectives:

- Listen and name common fruits.
- Write the names of fruits and talk about them.
- Read a very short text and answer the questions.
- Write a few sentences by looking at the pictures.

Materials:

pictures, sentence cards, word cards, real objects.

Before you teach:

1. Study the workbook thoroughly.
2. Have the materials ready.

1. Look and read

20 minutes

Activity (Warming up)

- Ask the students to study the pictures. (given in student workbook)
- Pointing to the picture, ask the questions. “What is it?” “Do you know it?”
- Encourage them to come up with the answers. Let them speak their own language and translate their words into English.

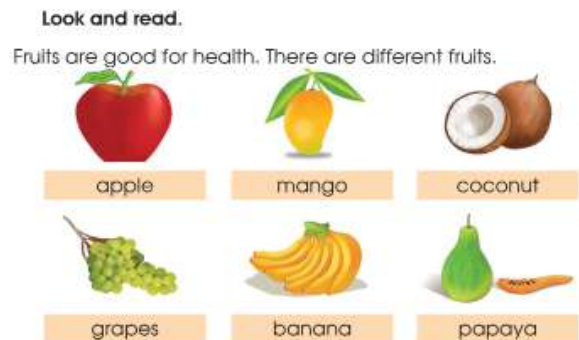

Activity 2 (Listen and do)

- Read the words of each picture and instruct them to listen. (Repeat it three/four times)
- Read the words of each picture and instruct them to flow him/her. (Repeat it three/four times)
- Instruct some students one by one to read the words and follow by others.
- Ask them to guess Nepali equivalent words and tell the equivalent words.
- Make a drill for pronunciation and spelling of the given words.

- Conduct a dictation and instruct them for self-correction and peer correction.
- Monitor and help needy ones.

Activity 3 (Speaking practice)

- Distribute the pictures to each student. (one picture for one student)
- Take one picture and demonstrate as example. E.g. Show the picture of an apple and ask “What is it?” It is an apple.
- Instruct them to talk in pairs about their pictures. (Also instruct them to change their partners as needed.) Monitor and help needy ones.
- Invite some pairs in front and ask them to perform. Facilitate them as their need.

2. Write

5 minutes

Activity 1 (Speaking and writing)

- Ask them to look at the activity “Write” in their book.
- Instruct them to discuss in pairs and small groups (within their desk) and complete the given task.
- Invite two/three students one by one in front of the class and ask them to show their writing (names of fruit) to the whole class. Help them as needed.
- Monitor and help them to correct their writing tasks.



3. Read and write

20 minutes

Activity 1 (Aloud reading)

- Ask the students to look at the picture and discuss. (Asking such a question “What do you see in the picture?”)
- Read the text and instruct them to listen. (Repeat it two/three times)
- Read the text and instruct them to follow. (Repeat it two/three times)
- Ask some students one by one to read the text and instruct the others to follow. Facilitate them to read correctly as they need.
- Invite some students in front and ask them to read one by one. Facilitate them to read correctly.
- Teach the meaning of green and yellow.

Activity 2 (Reading for comprehension)

- Write the comprehension questions with space of writing answers on the board and instruct them to study the questions.

- Instruct them to read the text and find the answers.
- Ask them to write their answers in their notebooks and share it in pairs and small groups.
- Instruct them to discuss in groups and decide the correct answers.
- Invite a student from any group and instruct him/her to write the answers on the board.
- Ask the other groups to correct the answers. Facilitate them to write the correct answers as needed.
- Now, instruct them to write the correct answers in their books. Monitor and help needy ones.

Read and write.

The Papaya Tree

This is a papaya tree.
The tree is tall.
The tree has four papayas.
Papayas are green and yellow.
I like papayas.



1. What tree is this?

2. Is the tree tall?

3. How many papayas does the tree have?

4. What colour are papayas?

4. Write three sentences about the picture 15 minutes

Activity 1 (Warming up)

- Ask the students to look at the picture and ask them “What do you see in the picture?”
- Ask them to write the three names of fruit what they see in the picture. Monitor and help needy ones.

Write three sentences about the picture.



1. _____
2. _____
3. _____

Activity 2 (Writing)

- Write the three names of fruit as an example what you see in the picture on the board. Such as an apple, mango and banana.
- Instruct them to write three sentences using three names of fruit what they see in the picture.

Sample

Fruits are good for health. The boy likes an apple. The girl likes an banana.

- Monitor and encourage them to write variety of the sentences.
- Encourage the students to share their work before you correct them.
- After correction, instruct them to write these sentences in their books.

Lesson 99

A/An

In this lesson, there are three topics to cover:

1. Look and read (Listening and speaking)
2. Look and write 'a/an' (Using a/an)
3. Read and write (Reading)
4. Write three sentences about the picture (Writing)

Objectives:

- Identify the difference between using 'a and an'.
- Use a or an correctly.
- Write a few sentences by using a/an.

Materials:

pictures, word cards.

Before you teach:

1. Study the workbook thoroughly.
2. Have the materials ready.

1. Look and read

20 minutes

Activity (Warming up)

- Ask the students to study the pictures. (given in student workbook)
- Pointing to the picture, ask the questions such as 'What do you see in the picture?'
- Conduct a short discussion.



Activity 2 (Listen and do)

- Write the words with the article 'a' in one column and words with the article 'an' in another column on the board.

Column a	Column an
a tree	an apple
a book	an eye
a cat	an egg

- Ask the students to read the words and find the difference.
- "Why do we use 'a' with tree and 'an' with apple?" Ask this question to them and

get their response. (Encourage them to come up with different answers. Accept their responses in their own language.)

- Now, explain about the use of a/an.

We use 'a' with a noun starting with consonant letter (sound) and we use 'an' with a noun starting with vowel letter (sound). "a, e, i, o, u" are the vowel letters in English and other letters are consonants.

Write some nouns on the board and instruct them to separate the words starting with vowel and consonant letter.

book car ant eagle fan goat orange

- Instruct them to use a/an with these nouns. Monitor and help needy ones.
- Invite some students and ask them to write these words (nouns) with a/an on the board. Facilitate them as their need.

a book a car an ant an eagle a fan a goat an orange

- "Why do we use 'a' with book and 'an' with ant?" Ask this question to them and make a short discussion. (Encourage them to come up with different answers. Accept their responses in their own language.)

2. Look and write [a/an] 10 minutes

Activity 1 (Speaking and writing)

- Ask them to look at the activity "Look and write 'a/an'" in their book.
- Instruct them to discuss in pairs and small groups (within their desk) and complete the given task.
- Invite two/three students one by one in front of the class and ask them to tell the word with 'a/an' to the whole class. Help them as needed.
- Monitor and help them to correct their use of 'a/an'.



3. Read and write 20 minutes

Activity 1 (Aloud reading)

- Ask the students to look at the picture and discuss. (Asking such a question "What do you see in the picture?")
- Read the text and instruct them to listen. (Repeat it two/three times)

- Read the text and instruct them to follow. (Repeat it two/three times)
- Ask some students one by one to read the text and instruct the others to follow. Facilitate them to read correctly as they need.
- Invite some students in front and ask them to read one by one. Facilitate them to read correctly.

Read and write.

The Red Apple

This is an apple.
The apple is red.
I eat an apple everyday.
I drink apple juice.
I like apples very much.



1. Is this an apple?

2. What colour is the apple?

3. Do you like apples?

4. Do you eat an apple everyday?

Activity 2 (Reading for comprehension)

- Write the comprehension questions with space of writing answers on the board and instruct them to study the questions.
- Instruct them to read the text and find the answers.
- Ask them to write their answers in their notebooks and share it in pairs and small groups.
- Instruct them to discuss in groups and decide the correct answers.
- Invite a student from any group and instruct him/her to write the answers on the board.
- Ask the other groups to correct the answers. Facilitate them to write the correct answers as needed.
- Now, instruct them to write the correct answers in their books. Monitor and help needy ones.

4. Write three sentences about the picture 20 minutes

Activity 1 (Warming up)

- Ask the students to look at the picture and ask them “What do you see in the picture?”
- Ask them to write the three things what they see in the picture. Monitor and help needy ones.

Activity 2 (Writing)

- Write the three things as an example what you see in the picture on the board.

Such as an apple tree, a boy, a girl.

- Instruct them to write three sentences using 'a/an' what they see in the picture.

Write three sentences about the picture.



Sample

It is an apple tree. A boy eats an apple everyday

1. _____
2. _____
3. _____

- Monitor and encourage them to write variety of the sentences.
- Make correction by peer correction and checking by the teacher.
- After correction, instruct them to write these sentences in their books.

Lesson 100

Vegetables

In this lesson, there are three topics to cover:

1. Look and read (Listening and speaking)
2. Fill in the missing letters and colour. (Writing)
3. Read and write (Reading)
4. Look at the picture and write three sentences (Writing)

Objectives:

- Listen and identify vegetables.
- Talk about vegetables.
- Fill the missing letters. (names of vegetables)
- Read a short text and answer questions.
- Write a few sentences about vegetables by looking at the picture.

Materials:

pictures, word cards, real objects.

Before you teach:

1. Study the workbook thoroughly.
2. Have the materials ready.

1. Look and read

10 minutes

Activity (Warming up)

- Ask the students to study the pictures. (given in student workbook)
- Pointing to the picture, ask the questions. “What is it?” “Do you know it?”
- Encourage them to come up with the answers. Let them speak their own language and translate their words into English.

Activity 2 (Listen and do)

- Read the words of each picture and instruct them to listen. (Repeat it three/four times)

Look and read.

We eat vegetables everyday. Eating vegetables is good for our health.



a potato



a tomato



an onion



a pumpkin



a cauliflower



a cucumber

- Read the words of each picture and instruct them to flow him/her. (Repeat it three/four times)
- Instruct some students one by one to read the words and follow by others.
- Ask them to guess Nepali equivalent words and tell the equivalent words.
- Make a drill for pronunciation and spelling of the given words.
- Conduct a dictation and instruct them for self-correction and peer correction.
- Monitor and help needy ones.

2. Fill in the missing letters and colour

10 minutes

Activity 1 (Speaking practice)

- Distribute the pictures to each student. (one picture for one student)
- Take one picture and demonstrate as example. E.g. Show the picture of a potato and ask “What is it?” It is a potato.
- Instruct them to talk in pairs about their pictures. (Also instruct them to change their partners as needed.) Monitor and help needy ones.

Fill in the missing letters and colour.

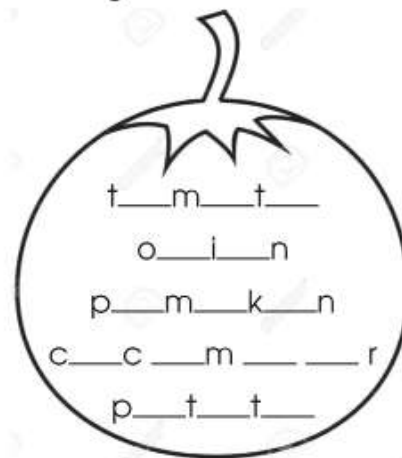

- Invite some pairs in front and ask them to perform. Facilitate them as their need.

Activity 2 (Filling in the missing letters and colouring)

- Ask them to look at the activity “Fill in the missing letters and colour” in their book.
- Instruct them to discuss in pairs and small groups (within their desk) and fill in the missing letters.
- Invite two/three students one by one in front of the class and ask them to show their filling letters to the whole class. Help them as needed.
- Monitor and help them to match words with correct pictures as they need.
- Ask a student to read the words and ask class to repeat after him/her. Do it with some students.

3. Read and write

15 minutes

Activity 1 (Aloud reading)

- Ask the students to look at the picture and discuss. (Asking such a question “What do you see in the picture?”)
- Read the text and instruct them to listen. (Repeat it two/three times)

- Read the text and instruct them to follow. (Repeat it two/three times)
- Ask some students one by one to read the text and instruct the others to follow. Help them as they needed.
- Invite some students in front and ask them to read one by one. Facilitate them to read correctly.
- Teach the meaning of round, shape and vegetable.

Read and write.

Hi Everyone !

Hi everyone!
I am a pumpkin.
I am round in shape.
I am green and yellow in colour.
I am a vegetable.
People like me a lot.



1. What is it?

2. What shape is it?

3. What colour is it?

4. Is it a vegetable or a fruit?

Activity 2 (Reading for comprehension)

- Write the comprehension questions with space of writing answers on the board and instruct them to study the questions.
- Instruct them to read the text and find the answers.
- Ask them to write their answers in their notebooks and share it in pairs and small groups.
- Instruct them to discuss in groups and decide the correct answers.
- Invite a student from any group and instruct him/her to write the answers on the board.
- Ask the other groups to correct the answers. Facilitate them to write the correct answers as needed.
- Now, instruct them to write the correct answers in their books. Monitor and help needy ones.

4. Look at the picture and write three sentences 15 minutes

Activity 1 (Warming up)

- Ask the students to look at the picture and ask them “What do you see in the picture?”
- Ask them to write the three names of vegetable what they see in the picture. Monitor and help needy ones.

Activity 2 (Writing)

- Write the three vegetables as an example what you see in the picture on the board. Such as pumpkin, cauliflower, tomato.

- Instruct them to write three sentences using three things what they see in the picture.

Look at the picture and write three sentences.



Sample

Vegetable are good for health. I eat ton 1.

- Monitor and encourage them to write variety of the sentences. 2.

- Make correction by peer correction and checking by the teacher. 3.

- After correction, instruct them to write these sentences in their books.

Handwriting practice lines consisting of three sets of horizontal lines. The first set is partially filled with the text from the 'Sample' section.

Theme: Hobbies and Interests

Hobbies and interest is one of the themes prescribed in the curriculum. The texts and activities presented in the lessons are related to hobbies and interest. The learners will involve in their activities of interest. They will learn to express their likes and dislikes. It will support the learners to get exposure to the contents and vocabularies about this theme. As a result, the learners will be able to comprehend and talk about them.

Number of Lessons: 2

Lesson Topics

1. I Like Fruits (Lesson 101)
2. I Don't Like Leaves (Lesson 102)

Soft skills

- Creativity
- Creative thinking
- Self-esteem
- Communication
- Active listening

Language function

- Expressing likes and dislikes

Skill-wise learning outcomes

Listening

1. Recognize and comprehend words and simple expressions.

2. Respond to the audio or the teacher non-verbally and verbally.
3. Perform different kinds of listening tasks (e.g. drawing, matching, etc.).

Speaking

1. Pronounce grade appropriate words correctly.
2. Ask and answer short, simple questions.
3. Sing or recite a song/chant by listening to the teacher or an audio.

Reading

1. Recognize and read familiar words accompanied by visuals
2. Perform rhymes and chants with appropriate rhyme and rhythm.
3. Understand the meaning of grade appropriate words.
4. Read words, simple sentences and short paragraphs correctly.
5. Retrieve specific information from simple sentences.
6. Do different kinds of comprehension tasks (answering verbally, matching, action, etc.)

Writing

1. Write letters and words in a straight line from left to right with regular spacing between words.
2. Copy letters and highly frequent familiar words and phrases correctly and reproduce them.
3. Combine and recombine different letters to form words, and put the words in correct order to form simple sentences.
4. Use correct spelling of the words.
5. Write simple phrases and sentences independently.
6. Demonstrate handwriting skills.

Lesson 101

I Like Fruits

In this lesson, there are three topics to cover:

1. Look and read (Listening and speaking)
2. Complete the sentences (Speaking and writing)
3. Read and write (Reading)
4. Make words and write three sentences (Writing)

Objectives:

- Listen and identify about use of 'like'.
- Talk using like.
- Complete the sentences using like as given clues.
- Read a very short text and answer the questions.
- Write a few sentences by using 'like'.

Materials:

pictures, sentence cards, word cards.

Before you teach:

1. Study the workbook thoroughly.
2. Have the materials ready.

1. Look and read

15 minutes

Activity 1 (Warming up)

- Greet them by saying 'Good morning/afternoon class' and get back the response.
- Show them the picture and instruct the students to study.
- Point to each picture and ask question in whole class, in group and individually. (What do you see in the picture?)
- Encourage them to come up with the answers. Let them speak their own language and translate their words into English.

Look and read.

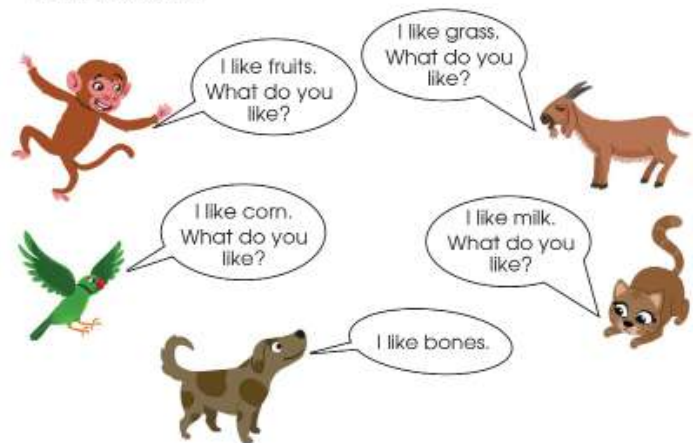

Activity 2 (Listen and do)

- Read the sentences of each picture and instruct them to listen. (Repeat it $\frac{3}{4}$ times)

- Read the sentences of each picture and instruct them to flow him/her. (Repeat it ¾ times)
- Instruct them to read the sentences of each picture.
- Invite some students in front of the class one by one. Instruct them to read sentences of each picture and follow by others. (Facilitate them to read the sentences.)
- Ask randomly some students to stand up and read the sentences of each picture. (Focus on slow learners)

Activity 3 (Speaking practice)

- Write the words: dance, read, draw, play and jump on the board and make a short discussion. (You can tell the equivalent Nepali words)
- Distribute word cards to each student.

dance **read** **draw** **play** **jump**

- Take a word card and demonstrate as an example such as ‘I like to dance.’
- Form a circle and instruct them to perform as their word cards. (This activity can be performed outside the classroom.)
- Instruct them make a pair and talk to their partners. (one asks and other answers)
e. g. A: What do you like to do?
B: I like to play.
- Instruct them to make new partner and talk to their partners.
- Randomly ask some students ‘What do you like to do?’ and instruct them to perform as a word card.

2. Complete the sentences 10 minutes

Activity 1 (Speaking and writing)

- Ask them to look at the activity “Complete the sentences” in their book.
- Instruct them to discuss in pairs and small groups (within their desk) and complete the given task.
- Invite two/three students one by one in front of the class and ask them to write the sentences on the board. Help them as needed.
- Instruct them to correct their task as written on the board.

Complete the sentences.

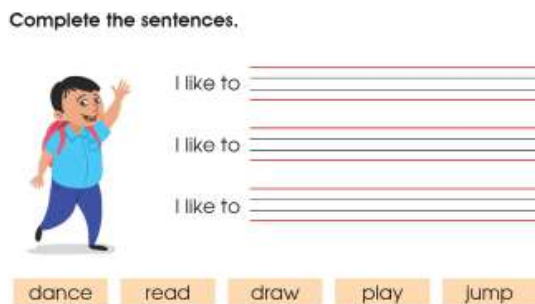

I like to _____

I like to _____

I like to _____

dance read draw play jump

3. Read and write

20 minutes

Activity 1 (Aloud reading)

- Ask the students to look at the picture and discuss. (Asking such a question “What do you see in the picture?”)
- Read the text and instruct them to listen. (Repeat it two/three times)
- Read the text and instruct them to follow. (Repeat it two/three times)
- Ask some students to read the text one by one and instruct the others to follow. Facilitate them to read correctly as they need.
- Invite some students in front and ask them to read one by one. Facilitate them to read correctly as their need.
- Teach the meaning of words paints, painting.

Activity 2 (Reading for comprehension)

- Write the comprehension questions with space of writing answers on the board and instruct them to study the questions.
- Instruct them to read the text and find the answers.
- Ask them to write their answers in their notebooks and share it in pairs and small groups.
- Instruct them to discuss in groups and decide the correct answers.
- Invite a student from any group and instruct him/her to write the answers on the board.
- Ask the other groups to correct the answers. Facilitate them to write the correct answers as needed.
- Now, instruct them to write the correct answers in their books. Monitor and help needy ones.

Read and write.

Painting

Saru likes to paint.
She paints a house.
Sagar likes to paint too.
He paints a tree.
They both like painting.



1. What does Saru like?

2. What does Saru paint?

3. What does Sagar paint?

4. What do they both like?

4. Make words and write three sentences

15 minutes

Activity 1 (Warming up)

- Ask the students to look at the picture and ask them “What do you see in the picture?”
- Ask them to guess and make words from given unscrambled words.
- Ask them to write the three words in their books.

Make words and write three sentences.



siwm _____
pciture _____
darw _____

1. picture : _____
2. draw : _____
3. swim : _____

Activity 2 (Writing)

- Ask them to make three sentences using these three words; picture, draw and swim.
- Monitor and help to write the sentences.
- Invite some students in front and instruct them to write on the board.
- Make correction by peer correction and checking by the teacher.
- After correction, instruct them to write these sentences in their books

Sample

Sagun likes picture. She likes to draw. Bikash likes to swim.

Lesson 102

I Don't Like Leaves

In this lesson, there are three topics to cover:

1. Look and read (Listening and speaking)
2. Read and write (Reading)
3. Write what you can and can't do (Writing)

Objectives:

- Listen and identify about use of 'don't like'.
- Talk using 'don't like'.
- Complete the sentences using 'like and don't like'.
- Read a very short text and answer the questions.
- Write a few sentences by looking at the pictures.

Materials:

pictures, rhyme chart, word cards.

Before you teach:

1. Study the workbook thoroughly.
2. Have the materials ready.

1. Look and read.

10 minutes

Activity 1 (Warming up)

- Greet them by saying 'Good morning/afternoon class' and get back the response.
- Show them the picture and instruct the students to study.
- Point to each picture and ask question in whole class, in group and individually. (What do you see in the picture?)
- Encourage them to come up with the answers. Let them speak their own language and translate their words into English.

Activity 2 (Listen and do)

- Read the sentences of each picture and instruct them to listen. (Repeat it $\frac{3}{4}$ times)
- Read the sentences of each picture and instruct them to flow him/her. (Repeat it $\frac{3}{4}$ times)
- Instruct them to read the sentences of each picture.
- Invite some students in front of the class one by one. Instruct them to read sentences of each picture and follow by others. (Facilitate them to read the sentences.)

- Ask randomly some students to stand up and read the sentences of each picture. (Focus on slow learners)

2. Write what you like to do and don't like to do 15 minutes

Activity 1 (Speaking practice)

- Ask some students individually “What do you like to do? What don't you like to do?” Facilitate them by giving examples such as I like to dance. I don't like to sing.
- Ask them to write 4/4 things in their notebooks that they like and don't like to do. Monitor the class and help needy ones.
- Keep them in circle and ask them to tell/share what they like to and what they don't like to do. Facilitate their presentation/performance. (Repeat it two/three times)

Activity 2 (Speaking and writing)

- Ask them to look at the activity “Write what you like to do and don't like to do” in their book.
- Instruct them to discuss in pairs and small groups (within their desk) and complete the given task.
- Invite two/three students one by one in front of the class and ask them to write the sentences on the board. Help them as needed.
- Instruct them to correct their task as written on the board.

3. Read and write 20 minutes

Activity 1 (Aloud reading)

- Ask the students to look at the picture and discuss. (Asking such a question “What do you see in the picture?”)
- Read the text and instruct them to listen. (Repeat it two/three times)
- Read the text and instruct them to follow. (Repeat it two/three times)
- Ask some students to read the text one by one and instruct the others to follow. Facilitate them to read correctly as they need.
- Invite some students in front and ask them to read one by one. Facilitate them to read correctly as their need.
- Teach the meaning of words ‘holes, carrots, leaves.

Activity 2 (Reading for comprehension)

- Write the comprehension questions with space of writing answers on the board

and instruct them to study the questions.

- Instruct them to read the text and find the answers.
- Ask them to write their answers in their notebooks and share it in pairs and small groups.
- Instruct them to discuss in groups and decide the correct answers.
- Invite a student from any group and instruct him/her to write the answers on the board.
- Ask the other groups to correct the answers. Facilitate them to write the correct answers as needed.
- Now, instruct them to write the correct answers in their books. Monitor and help needy ones.

4. Make words and write sentences

15 minutes

Activity 1 (Warming up)

- Ask the students to look at the picture and ask them “What do you see in the picture?”
- Ask them to guess and make words from given unscrambled words.
- Ask them to write the three words in their books.

Activity 2 (Writing)

- Ask them to make three sentences using these three words; angry, under and bone.
- Monitor and help to write the sentences.
- Invite some students in front and instruct them to write on the board.
- Encourage the students to share their work before you correct them.
- After correction, instruct them to write these sentences in their books.

Sample

A boy looks angry. A cat is under the bed. A dog likes a bone.

Theme: Birds and Animals

The texts and activities presented in the lessons are related to birds and animals. The texts and activities about describing size, shape, colour, food, habitats and using prepositions (in, on, under) are also incorporated. It will support the learners to get exposure to the contents and vocabularies about this theme. As a result, the learners will be able to comprehend and talk about them.

Number of Lessons: 6

Lesson Topics

1. The Tiger (Lesson 103)
2. The Cock (Lesson 104)
3. Birds in the Tree (Lesson 105)
4. On/In/Under (Lesson 106)
5. Big and Small (Lesson 107)
6. My Pet (Lesson 108)

Soft skills

- Respect for nature
- Communication
- Critical thinking

Language function

- Describing objects, pictures and animals

Skill-wise objectives

Listening

1. Match spoken words to printed words (e.g. the teacher pronounces /pin/, and the student selects pin from a set of three word cards).
2. Recognize and comprehend words and simple expressions.
3. Respond to the audio or the teacher non-verbally and verbally.
4. Respond to simple commands and questions.
5. Perform different kinds of listening tasks (e.g. drawing, matching, etc.).

Speaking

1. Pronounce grade appropriate words correctly.
2. Give basic personal information about themselves (e.g. name, address, family, nationality) using short words and phrases.
3. Ask and answer short, simple questions.
4. Sing or recite a song/chant by listening to the teacher or an audio.
5. Name people, objects and places and describe them with adjectives.

Reading

1. Recognize and read familiar words accompanied by visuals
2. Perform rhymes and chants with appropriate rhyme and rhythm.
3. Understand the meaning of grade appropriate words.

4. Read words, simple sentences and short paragraphs correctly.
5. Retrieve specific information from simple sentences.
6. Do different kinds of comprehension tasks (answering verbally, matching, action, etc.)

Writing

1. Write letters and words in a straight line from left to right with regular spacing between words.
2. Copy letters and highly frequent familiar words and phrases correctly and reproduce them.
3. Combine and recombine different letters to form words, and put the words in correct order to form simple sentences.
4. Use correct spelling of the words.
5. Write simple phrases and sentences independently.
6. Demonstrate good handwriting skills.

Lesson 103

The Tiger

In this lesson, there are three topics to cover:

1. Look and sing (Listening and speaking)
2. Write the names of animals (Speaking and writing)
3. Read and Write (Reading)
4. Look at the picture and write three words and two sentences (Writing)

Objectives:

- Listen and identify animals.
- Write and talk about animals by looking at the pictures.
- Read a very short text and answer the questions orally.
- Write a few sentences by looking at the pictures.

Materials:

pictures, chant, word cards.

Before you teach:

1. Study the workbook thoroughly.
2. Have the materials ready.

1. Look and sing

15 minutes

Activity 1 (Warming up)

- Sing the following chant and ask them to listen to you first.
- Paste the rhyme chart on the wall or you can write the chant on the board, ask them to sing with you together.
- Invite the students to the front of the class and ask them to sing the chant.
- Make sure that they are saying the words correctly.

Look and sing.
This is a jungle. It is home to many animals.



I found a cow !
How?
I found a cow !
How?
I found a bear !
Where?
I found a bear !
Where?
I found a hen !
When?
I found a hen !
When?

Activity 2 (Listening and speaking)

- Show them the picture (Given in the book) and instruct the students to study.
- Point to each picture and ask question in whole class, in group and individually. What is it? Where do you find it? (jackal, deer, elephant, monkey, tiger, bear)
- Divide the whole class into two groups and instruct them to stand in line. (looking

at face to face)

- Distribute word cards to one group and picture to another one.
- Instruct them to find the partners by matching a picture and word and talk about it. Monitor and facilitate them.

A: What is it? Where do you find it?

B: It is a tiger. I find it in the jungle.

- Randomly invite two/three pairs and instruct them to perform.

2. Write the names of animals

5 minutes

Activity 1 (Speaking and writing)

- Ask them to look at the activity “Write the names of animals” in their book.
- Instruct them to discuss in pairs and complete the given task.
- Instruct them to share in a small group and correct.

Write the names of animals.

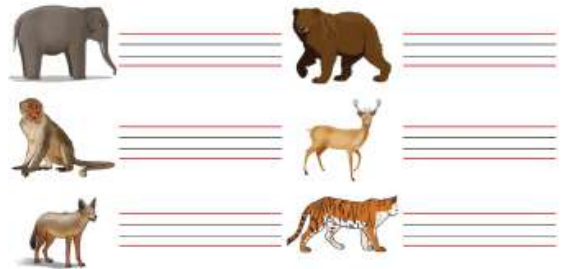

- Invite two/three students one by one in front of the class and ask them to show and read.
- Make a correction if needed and instruct them to correct in their books.

3. Read and write

20 minutes

Activity 1 (Aloud reading)

- Ask the students to look at the picture and discuss. (Asking such a question “What do you see in the picture?”)
- Read the text and instruct them to listen. (Repeat it two/three times)
- Read the text and instruct them to follow. (Repeat it two/three times)
- Ask some students to read the text one by one and instruct the others to follow. Facilitate them to read correctly as they need.
- Invite some students in front and ask them to read one by one. Facilitate them to read correctly as their need.
- Teach the meaning of words paints, painting.

Read and write.

The Tiger Again

This is a tiger.
The tiger eats meat.
The tiger has a strong body.
The tiger lives in the jungle.
The tiger is a wild animal.



1. What is this?

This is a _____

2. Where does the tiger live?

The tiger lives in _____

3. What does the tiger eat?

The tiger eats _____

4. Is the tiger a wild animal?

Activity 2 (Reading for comprehension)

- Write the comprehension questions with space of writing answers on the board and instruct them to study the questions.
- Instruct them to read the text and find the answers.
- Ask them to write their answers in their notebooks and share it in pairs and small groups.
- Instruct them to discuss in groups and decide the correct answers.
- Invite a student from any group and instruct him/her to write the answers on the board.
- Ask the other groups to correct the answers. Facilitate them to write the correct answers as needed.
- Now, instruct them to write the correct answers in their books. Monitor and help needy ones.

4. Look at the picture and write three words and two sentences. 20 minutes

Activity 1 (Warming up)

- Ask the students to look at the picture and ask them “What do you see in the picture?”
- Ask them to find three things in the pictures and write them in words in their notebook. (Facilitate to find three things.)
- Ask them to write the three words in their books. Monitor and help needy ones. (Three words: zoo, zebra and giraffe)



Activity 2 (Writing)

- Ask them to make two sentences using these three words; zoo, zebra and giraffe.
- Monitor and help to write the sentences.
- Invite some students in front and instruct them to write on the board.
- Encourage the students to share their work before you correct them.
- After correction, instruct them to write these sentences in their books.

Sample

It is a zoo. Giraffe and zebra live here.

Lesson 104

The Cock

In this lesson, there are three topics to cover:

1. Look and read (Listening and speaking)
2. Read and write (Reading)
3. Write what you can and can't do (Writing)

Objectives:

- Listen and identify names of birds.
- Colour the name of birds and talk.
- Read a short text and answer questions.
- Write a few sentences by looking at the pictures.

Materials:

pictures, rhyme chart, word cards.

Before you teach:

1. Study the workbook thoroughly.
2. Have the materials ready.

1. Look and discuss

10 minutes

Activity (Warming up)

- Ask the students to study the pictures. (given in student workbook)
- Pointing to the picture, ask the questions such as 'What is it?'
- Conduct a short discussion.

Look and discuss.



Activity 2 (Listen and do)

- Writes the words (names of birds) on the board.

a cock	a duck	a parrot	a pigeon
---------------	---------------	-----------------	-----------------

- Read the words and instruct them to flow him/her. (Repeat it three/four times)
- Instruct some students one by one to read the words and follow by others.
- Read the words and show the related pictures one by one. E. g. Read a word 'cock' and show a picture of cock. (Repeat it two/three times)
- Ask them to guess Nepali equivalent words and tell the equivalent words.
- Conduct a dictation and instruct them for self-correction and peer correction.
- Monitor and help needy ones.

2. Colour the name of this bird.

10 minutes

Activity 1 (Colouring and speaking)

Colour the name of this bird.

- Ask them to look at the activity “Colour the name of this bird” in their book.
- Ask the students in whole, group and individually. “Do you know it? What is the name of this bird?”
- Instruct them to colour the name of this bird.



cock

duck

parrot

pigeon

duck

- Present a sample in the class and instruct them to talk in pair about a duck. Monitor and facilitate.

A duck is a bird. It lives in water. It loves water.

- Invite some students one by one in front of the class and ask them to talk about it.

3. Read and write

20 minutes

Activity 1 (Aloud reading)

- Ask the students to look at the picture and discuss. (Asking such a question “What do you see in the picture?”)
- Read the text and instruct them to listen. (Repeat it two/three times)
- Read the text and instruct them to follow. (Repeat it two/three times)
- Ask some students to read the text one by one and instruct the others to follow. Facilitate them to read correctly as they need.
- Invite some students in front and ask them to read one by one. Facilitate them to read correctly as their need.

Read and write.

Kukhuri Kaa

This is a cock.
The cock runs very fast.
The cock is red and black.
The cock eats grains.
The cock says kukhuri kaa.



1. What is this?

2. What does the cock do?

3. What does the cock eat?

4. What does the cock say?

Activity 2 (Reading for comprehension)

- Write the comprehension questions with space of writing answers on the board and instruct them to study the questions.

- Instruct them to read the text and find the answers.
- Ask them to write their answers in their notebooks and share it in pairs and small groups.
- Instruct them to discuss in groups and decide the correct answers.
- Invite a student from any group and instruct him/her to write the answers on the board.
- Ask the other groups to correct the answers. Facilitate them to write the correct answers as needed.
- Now, instruct them to write the correct answers in their books. Monitor and help needy ones.

4. Look and write two sentences.

20 minutes

Activity 1 (Warming up)

- Ask the students to look at the picture and ask them “What do you see in the pictures?” (Make words)
- Ask them to write the words by scrambling the letters in the notebook.
- Ask them to write these three words in their books. Monitor and help needy ones. (Three words: duck, pigeon, parrot)
- Instruct them to look at the picture and discuss. (Look and write two sentences.)
- Instruct them to find three things from the picture. (Three words: a parrot, a cage, a girl)

Look and write two sentences.



1. _____
 2. _____

Make words.



dcuk _____
 pegoin _____
 prraot _____

Activity 2 (Writing)

- Ask them to make two sentences using these three words; a parrot, a cage, a girl.
- Monitor and help to write the sentences.
- Invite some students in front and instruct them to write on the board.
- Encourage the students to share their work before you correct them.
- After correction, instruct them to write these sentences in their books.

Sample

The parrot is in a cage. The girl loves a parrot.

Lesson 105

Birds in the Tree

In this lesson, there are three topics to cover:

1. Look and read (Listening)
2. Colour and write their names (speaking)
3. Read and write (Reading)
4. Look and write three sentences about the picture (Writing)

Objectives:

- Listen and identify names of birds.
- Colour the pictures of bird and talk.
- Read a short text and answer questions.
- Write a few sentences by looking at the pictures.

Materials:

pictures, rhyme chart, word cards.

Before you teach:

1. Study the workbook thoroughly.
2. Have the materials ready.

1. Look and read

15 minutes

Activity (Warming up)

- Ask the students to look at the pictures. (given in student workbook)
- Pointing to the picture, ask the questions. “What is it?” “Do you know it?”
- Encourage them to come up with the answers. Let them speak their own language and translate their words into English.



Activity 2 (Listen and do)

- Read the words of each picture and instruct them to listen. (Repeat it three/four times)
- Read the words of each picture and instruct them to flow him/her. (Repeat it three/four times)

- Instruct some students one by one to read the words and follow by others.
- Ask them to guess Nepali equivalent words and tell the equivalent words.
- Make a drill for pronunciation and spelling of the given words.
- Conduct a dictation and instruct them for self-correction and peer correction.
- Monitor and help needy ones.

2. Colour and write their names 10 minutes

Activity 1 (Colouring and writing)

- Ask them to look at the activity “Colour and write their names” in their book.
- Instruct them to discuss in pairs and colour them.
- Monitor and help them to colour them properly.
- Ask them to write the names of these birds.
- Instruct them for peer correction.
- Monitor and help needy ones.

Colour and write their names.

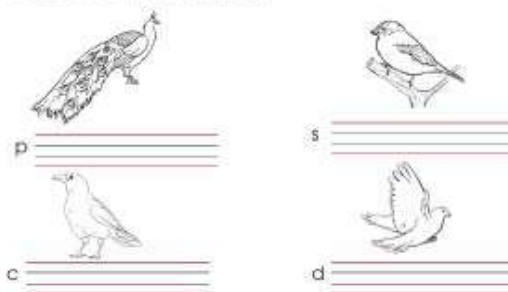

Activity 2 (Speaking Practice)

- Ask them to make a sentence for each picture. (Give about two minutes for preparation)
- Instruct them to talk in pairs about the pictures with a sentence of each picture. E.g. Peacock likes to dance. Sparrow is a small bird. Crow is a black bird. Dove can fly.
- Randomly ask some students to talk about them and facilitate in their talking.

3. Read and write 20 minutes

Activity 1 (Aloud reading)

- Ask the students to look at the picture and discuss. (Asking such a question “What do you see in the picture? Do you like this bird?”)
- Read the text and instruct them to listen. (Repeat it two/three times)
- Read the text and instruct them to follow. (Repeat it two/three times)
- Ask some students one by one to read the text and instruct the others to follow. Facilitate them to read correctly as they need.
- Invite some students in front and ask them to read one by one. Facilitate them to read correctly.

Read and write.

The Sparrow

Sparrow is a small bird.
It has a short tail.
It is brown in colour.
It eats seeds and fruits.
It chirps and dances.
It makes a nest in our house.



1. What is a sparrow?

2. What does the sparrow eat?

3. What does the sparrow do?

4. Where does the sparrow make its nest?

- Teach the meaning of words: tail, brown, seed, chirp and nest. (Ask them to guess Nepali equivalent words and tell the equivalent words.)
- Make a drill for pronunciation and spelling.
- Conduct a dictation and instruct them for self-correction and peer correction.

Activity 2 (Reading for comprehension)

- Write the comprehension questions with space of writing answers on the board and instruct them to study the questions.
- Instruct them to read the text and find the answers.
- Ask them to write their answers in their notebooks and share it in pairs and small groups.
- Instruct them to discuss in groups and decide the correct answers.
- Invite a student from any group and instruct him/her to write the answers on the board.
- Ask the other groups to correct the answers. Facilitate them to write the correct answers as needed.
- Now, instruct them to write the correct answers in their books. Monitor and help needy ones.

4. Look and write three sentences about the picture 15 minutes

Activity 1 (Warming up)

- Ask the students to look at the picture and ask them “What do you see in the picture?”
- Ask them to write the names of the birds which they see in the picture. Monitor and help needy ones.

Look and write three sentences about the picture.



1. _____
2. _____
3. _____

Activity 2 (Writing)

- Write the names of birds as an example what you see in the picture on the board. Such as parrot, pigeon, sparrow, dove and peacock.
- Instruct them to write three sentences using these names of bird what they see in the picture.

Sample

Parrot is green in colour. Sparrow and dove are brown in colour. Peacock dances.

- Monitor and encourage them to write variety of the sentences.
- Encourage the students to share their work before you correct them.
- After correction, instruct them to write these sentences in their books.

Lesson 106

On/In/Under

In this lesson, there are three topics to cover:

1. Look and read (Listening)
2. Where is the rabbit (Speaking)
3. Read and write (Reading)
4. Write three sentences about the picture (Writing)

Objectives:

- Listen and identify the use of on, in and under.
- Fill on/in/under by looking at the pictures.
- Talk using on, in and under.
- Read a short text and answer the comprehension questions.
- Write a few sentences by looking at the picture.

Materials:

pictures, word cards.

Before you teach:

1. Study the workbook thoroughly.
2. Have the materials ready.

1. Look and read

10 minutes

Activity (Warming up)

- Ask the students to study the pictures. (given in student workbook)
- Pointing to the picture, ask the questions. “What is it?” “Where is it?”
- Encourage them to come up with the answers. Let them speak their own language and translate their words into English.

Look and read.



The bird is on the elephant.
The rat is in the hole.
The cat is under the elephant.

Activity 2 (Listen and do)

- Read the words of each picture and instruct them to listen. (Repeat it three/four times)
- Read the words of each picture and instruct them to flow him/her. (Repeat it three/four times)
- Instruct some students one by one to read the words and follow by others.

2. Where is the rabbit?

15 minutes

Activity 1 (Using on/in/under)

- Ask them to look at the activity “Where is the rabbit?” in their book.
- Instruct them to look at the pictures and discuss in pairs.
- Pointing to the picture, ask the question “Where is the rabbit?” in whole, group and individually.
- Encourage them to tell the correct answer and appreciate their correct ones. E.g. Yes, you are right. The rabbit is on the table. (Accept their answer in Nepali language)
- Repeat the correct answer three/four times. E.g. Where is the rabbit? It is under the table.
- Make a short explanation about the use of on/in/under.
- Instruct them to write on/in/under in the gaps.

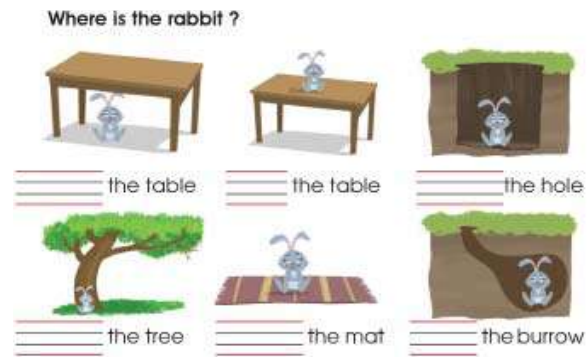

Activity 2 (Speaking Practice)

- Ask them to talk in pairs pointing to the given pictures.
A: Where is the rabbit?
B: It is under the table.
- Randomly ask some questions to them “Where is the duster? Where is the pen? Where is the book?”

3. Read and write

20 minutes

Activity 1 (Aloud reading)

- Ask the students to look at the picture and discuss. (Asking such a question “What do you see in the picture? Do you like this bird?”)
- Read the text and instruct them to listen. (Repeat it two/three times)
- Read the text and instruct them to follow. (Repeat it two/three times)
- Ask some students one by one to read the text and instruct the others to follow. Facilitate them to read correctly as they need.
- Invite some students in front and ask them to read one by one. Facilitate them to read correctly.
- Teach the meaning of words: garden. (Ask them to guess Nepali equivalent words and tell the equivalent words.)

Activity 2 (Reading for comprehension)

- Write the comprehension questions with space of writing answers on the board and instruct them to study the questions.
- Instruct them to read the text and find the answers.
- Ask them to write their answers in their notebooks and share it in pairs and small groups.
- Instruct them to discuss in groups and decide the correct answers.
- Invite a student from any group and instruct him/her to write the answers on the board.
- Ask the other groups to correct the answers. Encourage them to write the correct answers as needed.
- Now, instruct them to write the correct answers in their books. Monitor and help needy ones.

Read and write.

A Vegetable Garden

The girl is in the garden. It is a vegetable garden. A rabbit comes to her. He asks for a carrot.



1. Where is the girl?
2. Who comes to the girl?
3. What does the rabbit ask for?
4. The rabbit says, "Thanks". What does the girl say?

4. Write three sentences about the picture 15 minutes

Activity 1 (Warming up)

- Ask the students to look at the picture and ask them "What do you see in the picture?"
- Ask them to write three things what they see in the picture. Monitor and help needy ones.

Write three sentences about the picture.



1. _____
2. _____
3. _____

Activity 2 (Writing)

- Write three things as an example what you see in the picture on the board. Such as tree, sun, birds.
- Instruct them to write three sentences using these things what they see in the picture.

Sample

It is a tree. It is a sun. They are birds.

- Monitor and encourage them to write variety of the sentences.
- Encourage the students to share their work before you correct them.
- After correction, instruct them to write these sentences in their books.

Lesson 107

Big and Small

In this lesson, there are three topics to cover:

1. Look and discuss (Listening and speaking)
2. Look and read (Listening and speaking)
3. Read and write (Reading)
4. Write missing letters and write sentences using these words (Writing)

Objectives:

- Listen and identify the difference between big and small, fat and thin, tall and short.
- Talk using big and small, fat and thin, tall and short.
- Read a short text and answer the comprehension questions.
- Write a few sentences by using given words.

Materials:

Pictures, word cards

Before you teach:

1. Study the workbook thoroughly.
2. Have the materials ready.

1. Look and discuss

5 minutes

Activity 1 (Warming up)

- Talk about the pictures by asking the following questions to the students:
 - a. Pointing to each picture, ask the question: What do you see? (Encourage the students speak in English. If they can't, accept the answers in their own language too but tell them the English words.)
 - b. Which one is big?
 - c. Which one is small?

Look and discuss.



2. Look and read

20 minutes

Activity 1 (Listening and do)

- Write the following words (in pairs) on the board.
- Read these words in pairs such as big – small and instruct

big	small
fat	thin
tall	short

them to follow.

- “Do you know the meaning of these words?”, ask them and get their responses. Teach the meaning of these words. (Accept their responses in their own language. Also tell them the equivalent Nepali words)

Look and read.

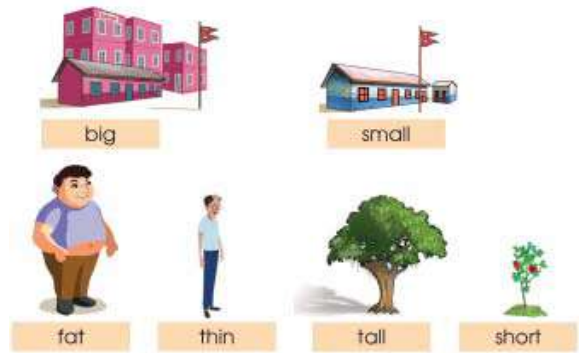

- Ask them to look at the activity “Look and read” in their book and study the pictures and words.
- Instruct them to read the words and discuss in pairs and groups.

Activity 2 (Speaking Practice)

- Distribute the pairs of pictures and instruct them to talk in their small groups. Such as
- Randomly invite some students and ask them to talk about the pictures.



3. Read and write

20 minutes

Activity 1 (Aloud reading)

- Ask the students to look at the picture and discuss. (Asking such a question “What do you see in the picture? Do you like this bird?”)
- Read the text and instruct them to listen. (Repeat it two/three times)
- Read the text and instruct them to follow. (Repeat it two/three times)
- Ask some students one by one to read the text and instruct the others to follow. Facilitate them to read correctly as they need.
- Invite some students in front and ask them to read one by one. Facilitate them to read correctly.
- Teach the meaning of words: grass and leaves. (Ask them to guess Nepali equivalent words and tell the equivalent words.)

Read and write.

The Elephant and Deer.

The elephant is big.
It has a big body.
The deer is small.
It has a small body.
They live in the jungle.
They eat grass and leaves.
They both are wild animals.



1. Who is big?

2. Who is small?

3. Where do they live?

4. What do they eat?

Activity 2 (Reading for comprehension)





- Write the comprehension questions with space of writing answers on the board and instruct them to study the questions.
- Instruct them to read the text and find the answers.
- Ask them to write their answers in their notebooks and share it in pairs and small groups.
- Instruct them to discuss in groups and decide the correct answers.
- Invite a student from any group and instruct him/her to write the answers on the board.
- Ask the other groups to correct the answers. Facilitate them to write the correct answers as needed.
- Now, instruct them to write the correct answers in their books. Monitor and help needy ones.

4. Write three sentences about the picture 15 minutes

Activity 1 (Warming up)

- Ask the students to look at the pictures and find the missing letters.
- Ask them to write the missing letters in their books. Monitor and help needy ones.
- Ask them to share to their peers and correct them.

Write missing letters.

 b _ _ _ k  t _ _ _ e  h _ _ n  e _ _ e

Write sentences using these words.

1. book : _____

2. tree : _____

3. hen : _____

Activity 2 (Writing)

- Write these words (book, tree, hen, and eye) on the board and instruct them to make one/one sentence using these words. (Provide two/three minutes)
- Invite the students one by one and ask them to write sentences using these words.

Sample

This is my English book. Tree is green. Hen is a bird. I have two eyes.

- Monitor and encourage them to write variety of the sentences.
- Encourage the students to share their work before you correct them.
- After correction, instruct them to write their own sentences in their books.

Homework

Write the sentences using these words in your four line notebook. (Collect their pages and make a booklet)

Lesson 108

My Pet

In this lesson, there are three topics to cover:

1. Look and read (Listening and speaking)
2. Look and write (Reading and writing)
3. Read and write (Reading)
4. Look and write three sentences about the picture (Writing)

Objectives:

- Listen and identify domestic animals.
- Talk about domestic animals.
- Fill the names of domestic animals by looking at the pictures.
- Read a short text and answer the comprehension questions.
- Write a few sentences by looking at the picture.

Materials:

Pictures, word cards

Before you teach:

1. Study the workbook thoroughly.
2. Have the materials ready.

1. Look and read

15 minutes

Activity (Warming up)

- Ask the students to study the pictures. (given in student workbook)
- Pointing to the picture, ask the questions. “What is it?” “Do you have it?”
- Encourage them to come up with the answers. Let them speak their own language and translate their words into English.

Look and read.



a buffalo a cow a goat a dog a sheep a cat

Activity 2 (Listen and do)

- Read the words of each picture and instruct them to listen. (Repeat it two/three times)
- Read the words of each picture and ask them to flow him/her. (Repeat it two/three times)

- Instruct some students one by one to read the words and follow by others.
- Ask them to guess Nepali equivalent words and tell the equivalent words.
- Make a drill for pronunciation and spelling of the given words.
- Conduct a dictation and instruct them for self-correction and peer correction.
- Monitor and help needy ones.

Activity 3 (Speaking practice)

- Distribute the pictures to each student. (one picture for one student)
- Take one picture and demonstrate as example. E.g. Show the picture of a buffalo and talk about it.

Sample

It is a buffalo. A buffalo is an animal. It gives milk.

- Instruct them to talk in pairs and groups about their pictures. (Also instruct them to change their partners as needed.) Monitor and help needy ones.
- Invite some students in front of the class and ask them to perform. Facilitate them as their need.

2. Look and write

10 minutes

Activity 1 (Reading and writing)

Look and write.

b		t	r	c
u	z	d		a
f	g	o	a	t
f	s	g		o
a	u	p	i	l
l	c	o	w	s
o	a		m	



- Ask them to look at the activity “Look and write” in their book.
- Instruct them to find the names of animal in the puzzle box and circle the words.
- Ask them to discuss in their groups and make a correction. (Monitor and help needy ones.)
- Now, instruct them to write these words at the right side of the pictures in their books.
- Invite two/three students one by one in front of the class and ask them to show their writing (names of domestic animals) to the whole class. Help them as needed.
- Monitor and help them to correct their writing tasks.

Activity 1 (Aloud reading)

- Ask the students to look at the picture and discuss. (Asking questions such as “What do you see in the picture? Do you love a dog?”)
- Read the text and instruct them to listen. (Repeat it two/three times)
- Read the text and instruct them to follow. (Repeat it two/three times)
- Ask some students one by one to read the text and instruct the others to follow. Facilitate them to read correctly as they need.
- Invite some students to front of the class and ask them to read the text one by one. Facilitate them to read correctly.
- Teach the meaning of words: pet and guards. (Ask them to guess Nepali equivalent words and tell the equivalent words.)

Read and write.

My Dog

I have a pet dog.
 His name is Kale.
 Kale is black in colour.
 It has long hair on its body.
 He guards our house. He runs very fast.
 He loves to play with me. I love him a lot.



1. Who is Kale?

2. What has Kale got on its body?

3. What does Kale do?

4. What does Kale love to do?

Activity 2 (Reading for comprehension)

- Write the comprehension questions with a space for writing answers on the board and instruct them to study the questions.
- Instruct them to read the text and find the answers.
- Ask them to write their answers in their notebooks and share it in pairs and small groups.
- Instruct them to discuss in groups and decide the correct answers.
- Invite a student from any group and instruct him/her to write the answers on the board.
- Ask the other groups to correct the answers. Facilitate them to write the correct answers as needed.
- Now, instruct them to write the correct answers in their books. Monitor and help needy ones.

4. Look and write three sentences about the picture 15 minutes

Activity 1 (Warming up)

- Ask the students “What do you see in the picture?”
- Ask them to write three things that they see in the picture. Monitor and help needy ones.

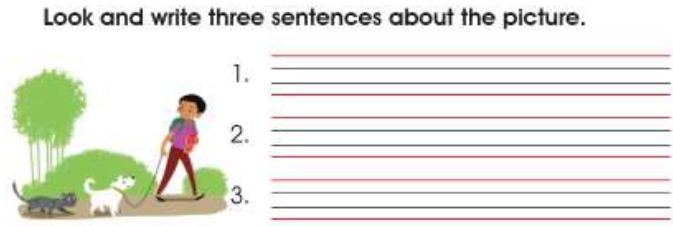

Activity 2 (Writing)

- Write three things as an example what you see in the picture on the board. Such as cat, dog and boy.
- Instruct them to write three sentences using these things what they see in the picture.

Sample

The boy has a dog. He has a cat. He loves them

- Monitor the progress and encourage them to write variety of the sentences.
- Make a peer correction before you correct them.
- After correction, instruct them to write their own sentences in their books.

